

APP[®]
AUTO-PLAST PRODUKT

2022 CATALOGUE



www.APP.com.pl

www.NTools.pl



APP

Leading distributor of products in the automotive trade, thanks to close cooperation with Customers.

APP consistently develops its network of Sales Representatives all around Europe.

Our advantage is an individual approach to the Customer and rich product offer.

We support our partners' development through attractive training courses and technical consulting. We indicate technological solutions and product innovations best suited to the Customer's needs.

We believe in direct relations and have the trust of nearly **20 000 Customers in 27 countries.**

Attractive prices distinguish us from other companies, but it's care for the quality of APP products that has elevated us to the leading position in the distribution of car refinishing products in many European countries.

ALL you need at the workshop

view the online catalogue



You are holding the new APP catalogue with our complete offer of over 3000 professional products. For your convenience, we have divided them into 4 specific trade categories:

To make locating the chosen product faster, each product group is coded with a different color. They are easy to find by the separators, table colors.

Each product has its individual number (index). If you want to see a video of its use, additional photos or a technical sheet, you can find it fastly by typing the corresponding index in the search bar on www.APP.com.pl or using the QR codes located by each of the products.



SPRAY-PAINTING



AUTO-CARE



SMART REPAIR



BODYWORK REPAIR

4 product categories with individual color coding

Technical parameters given in clear tables

Legible pictograms in clear tables and technical diagrams

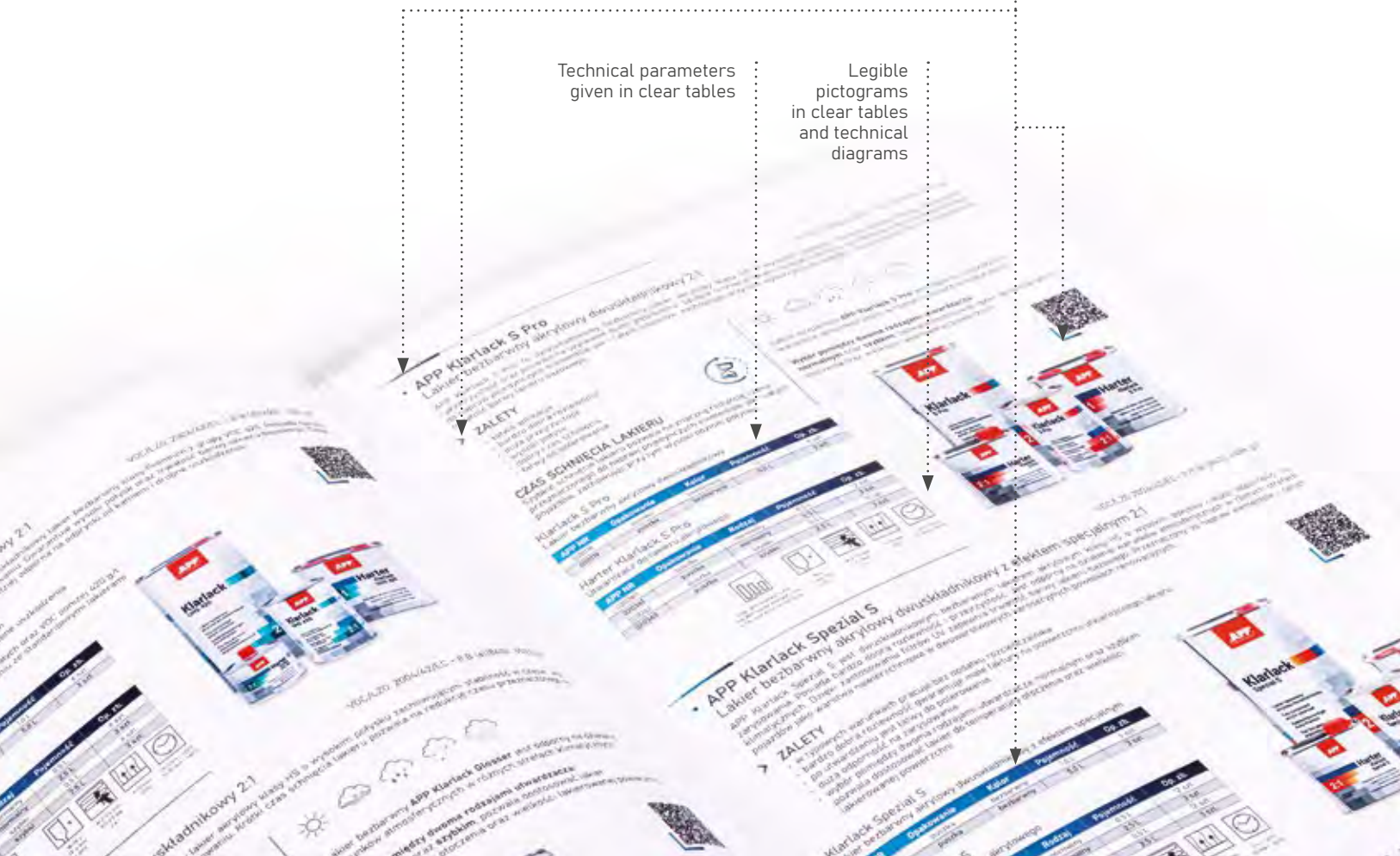

A simple choice

The catalog is complemented by a series of APP templates which – prior to making a purchase decision – enable you to check the execution quality, finishing method and physical properties relevant to the selected product.

Since 2016 you can use three templates :

- 1 SOUND INSULATING MATS**
Mats make it possible to measurably reduce the level of noise inside vehicles, even by several decibels. This template makes it possible to compare various thicknesses and technical properties of mats all in one place and select the optimal solution. It also contains other practical information, e.g. on the application of individual mats.
- 2 FILTERS for SPRAY BOOTHS**
Painting inside a spray booths requires high and constant air circulation, which is the primary carrier of dust particles and contaminants which cause damage to the painted surfaces. The use of appropriate filtration mats, their correct placement and the right exploitation time all have a huge influence on achieving the correct paint coating. This template contains all the information necessary to choosing the right filters for a specific spray booth.
- 3 GLUES, SEALANTS and BODYWORK PROTECTION PRODUCTS**
This template shows the differences in use and application methods of polymer, polyurethane masses, sealants and bodywork protection products. It indicates the correct application locations and allows to select appropriate products.



APP PRODUCTS

Advantage thanks to practice

Many years of experience in the automotive industry, knowledge of the market and customer expectations have allowed us to develop an offer tailored to diverse customer needs. Our products find application in industry, as well as large ASO service stations, medium-sized body and paint repair garages, and small paint shops and carpenter's workshops.

APP products are manufactured in advanced industrial plants managed in compliance with rigorous ISO 9001 and ISO 9002 European Standards. They are in line with environmental protection regulations based on directive 2004/42/CE concerning limitation of volatile organic compound emissions in paint shops through the use of low-emission products.

What affects the quality of our products?

- modern manufacturing technologies;
- strict adherence to technical standards;
- fast adaptation to changes in repair technologies
- continuous quality control of raw materials and finished products
- broad expertise in the area of our customers' quality expectations;
- availability of complete documentation for the offered products (TDS, MSDS).



NTools PRODUCTS

Tested in action

The NTools offer is a range of over 200 specialized devices for professionals. Our goal was to create equipment which meets the highest quality expectations, while taking into account their affordability for carrying out professional repairs. All our products meet the highest technical requirements.

They perform excellently in the hands of professionals. Before introduction into the offer, each tool has undergone multiple hours of stress tests and precise operation trials in the most difficult workshop conditions.

Machine servicing

Thanks to our NTools machine and equipment service you do can save time on tediously searching for a service and product shipping – you can arrange everything efficiently directly with your Sales Representative.

12 Plus Guarantee

NTools equipment is created for continued operation in the most demanding conditions. All tools are covered by a 12-month guarantee. Additionally, the guarantee can be extended to 36 months for selected products.

Interested in this product?
See more at www.NTools.eu



SMART Repair

SMART Repairs

This technology enables repairs of small surface defects and damage. Fast and efficient repair of car body and its interior as well. This repair technology additionally saves time and money, and which makes it increasingly popular with Insurance Companies during the loss assessment and loss adjustment procedure.

APP has been the first Company in Poland and East Europe to provide such a broad and professionally prepared offer of SMART Repair products. The SMART system enables faster repairs compared to traditional methods – repairs done within hours instead of days.

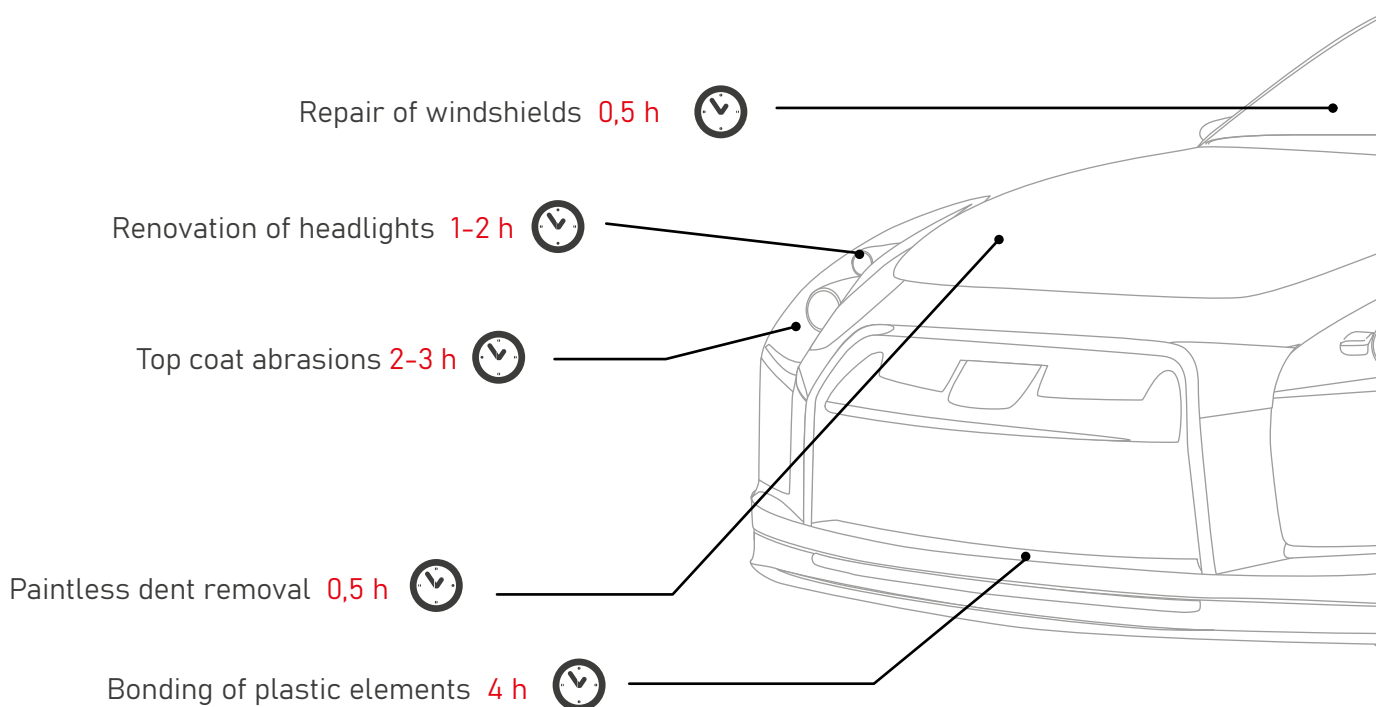

Higher turnover and profits

The SMART Repair services can be used in any car repair garage. They can be offered as an addition to repairs already provided to the customer – because every car will show aesthetic defects during exploitation (e.g. fender scratches, dents) which very often escape the customer's attention. By restoring the cars' original shine, we help them retain their value and serve the users' needs for longer.

➤ Check out the full training offer
See more at
www.szkolonia.tech



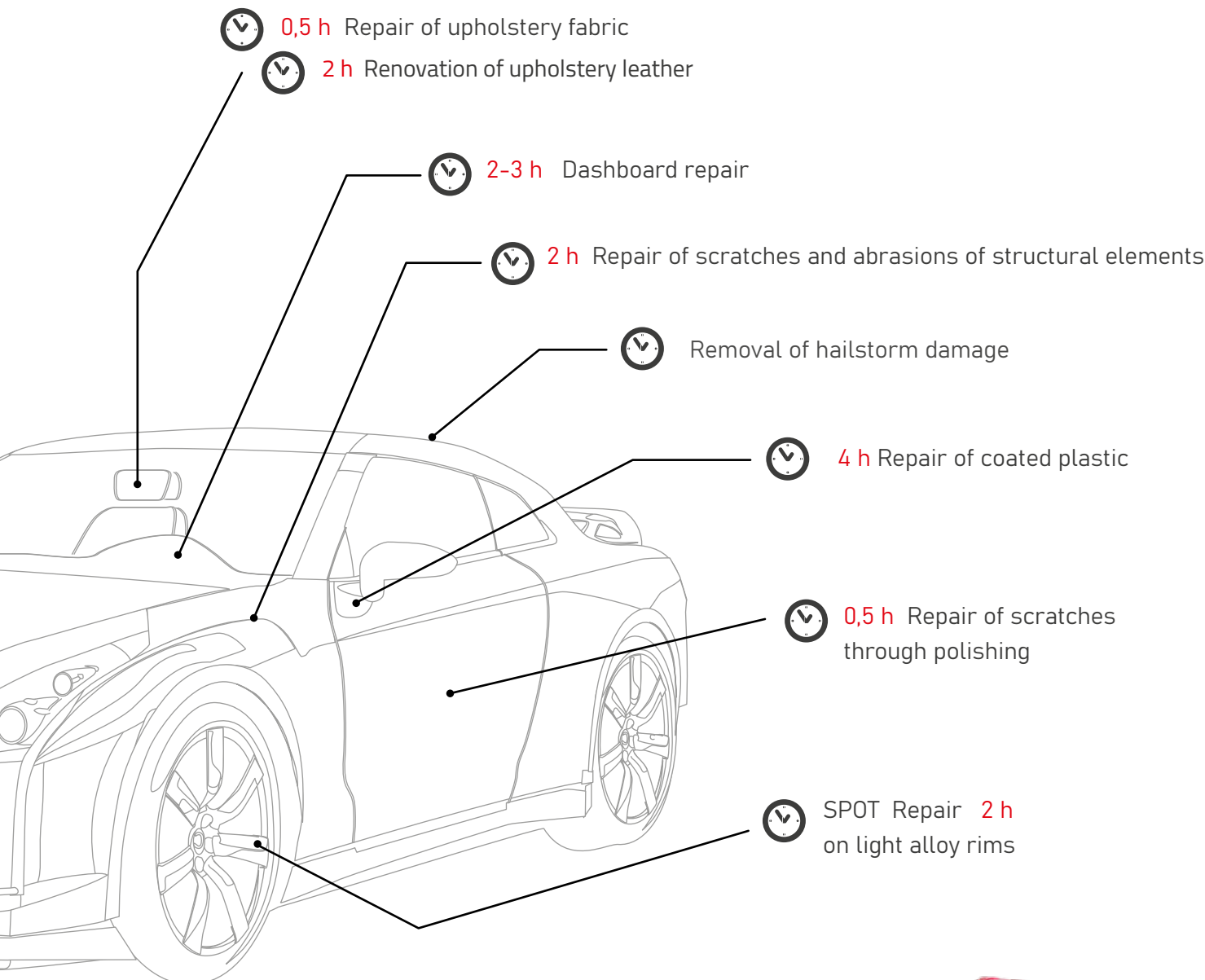

NTools Hot Stapler Set
Set for plastic material welding repairs

PDR

Paint-less dent removal

Paint-less Dent Removal (PDR) is the most rapidly developing vehicle bodywork repair technology. Its popularity is best explained by the benefits that can be achieved by all parties involved in the vehicle repair.

PDR – dent removal using the push out method

PDR wires are devices used to push out dents from the convex side of the damaged area. This technology allows to achieve ideal shape restoration of the repaired surface and, in more difficult cases, reduction of the defect by 70-90%.

These tools are characterized by a varying thickness and shape of endings, and are selected to correspond to the shape and location of the dent.

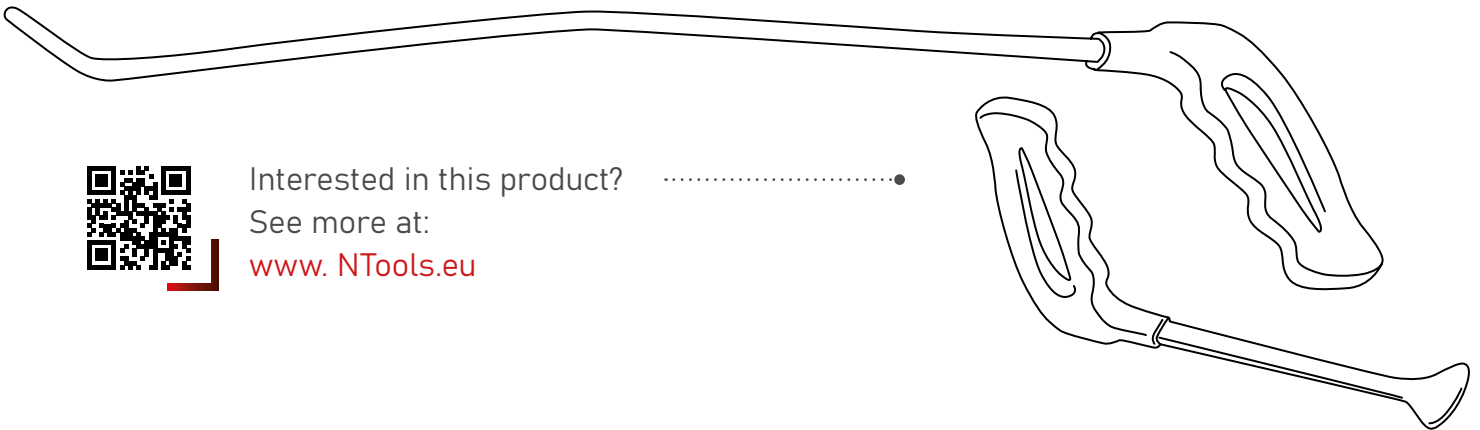

Interested in this product?

See more at:

www.NTools.eu

GLUE PULLER

– dent removal using the Glue Puller method

The Glue Puller method involves pulling out dents using a technique of gluing specially shaped and sized cups depending on the type of damage. These cups stick to the surface using a hot-melt glue. After hardening the bodywork part is pulled using a one or two-handed device (Puller).

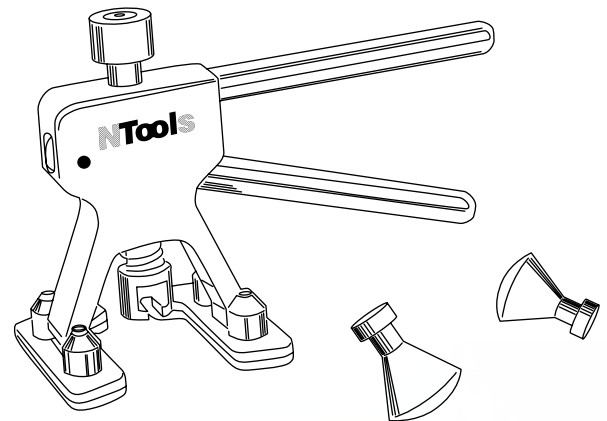

Mobile workstations

The mobile workstation allows for all tools to be in one place, so that there is no need to move away from the workplace in order to bring any missing tools or accessories.

NTools PDR System

A fully equipped trolley is an innovative workstation comprising a complete Paint-less Dent Removal system . The trolley features there a set of all instruments for paint-less dent removal on the inner side of the damage element – PDR and the necessary tools and accessories to carry out repairs on the outer side of the damaged element using the Glue Puller method.

NTools Car Body Repair System

A fully equipped trolley with a set of tools for spot repairs of steel and aluminum car bodywork panels. The system included with the trolley allows to perform all actions necessary to restore the original shape of damaged surfaces, and its most important elements are the NTools SPOT 300 and NTools ALU SPOT 3000 spotters.



Interested in this product?

See more at:

www.NTools.eu



NTools
PDR System



NTools
Car Body Repair System

APP MODULAR



Advanced color selection system

The modern and easy to maintain APP Modular guarantees performance of professional bodywork paint services. Thanks to the variety of available formulas it is possible to achieve any selected range of colors. The Software is regularly updated with new formulas and functions to facilitate operation. We offer our customers specialized training courses and direct oversight by our technical consultants operating all around the country.

The APP Modular color system has been developed for car bodywork paint-shops providing professional painting services.

The system's main advantages are:

- the system's ease of maintenance,
- the Modular formula system available on-line,
- a modern and professional construction,
- specialized training courses conducted by APP technical consultants,
- professional workshop image among customers.

The MODULAR Color Selection system includes:

- 1 mixing tool (mixer)
- 2 pigments
- 3 the MODULAR formula software
- 4 the ColorBOX color template (chromatic)
- 5 a board with a color table and wheel
- 6 a scale
- 7 a 5-angle spectrophotometer



MODULAR Special Base

MODULAR 2K Acryl Line

Interested in this product?
Call for detailed information: **+48 601 366 512**

Autodetailing

APP's offer of Auto Care Products is directed towards all professionals in the field of vehicle aesthetics, both in terms of their day to day care, as well as preparation for resale.

Our products can be used individually, as well as properly matched with others, in order to ensure a comprehensive solution to a problem:

- cleaning of upholstery,
- cleaning and maintenance of leather upholstery,
- removal of unpleasant odors,
- removal of volatile rust deposits, insects, bird excrement and bitumen,
- top coat polishing and renovation,
- application of a nano-protective coat (applies to the top coat, windshields and upholstery),
- engine compartment cleaning.

The final effects of using the APP and APP QUARTZ line Auto Care Products will satisfy the most demanding aesthetes.



on-line SUPPORT

Partner
area

Nothing but benefits

The APP Website offers special prices and additional services available for on-line customers. An advanced IT system allows to present a broad offer of available products, training courses and consulting services customized to the customer's individual needs.

After logging in, the user gains access to: currently available products, a pricelist according to individually negotiated volume credit, as well as full financial documentation, including history records of invoices.

We offer regular Customers a wide range of products at very attractive prices.



Register now

See more at:

<https://partner.e-app.pl/en>

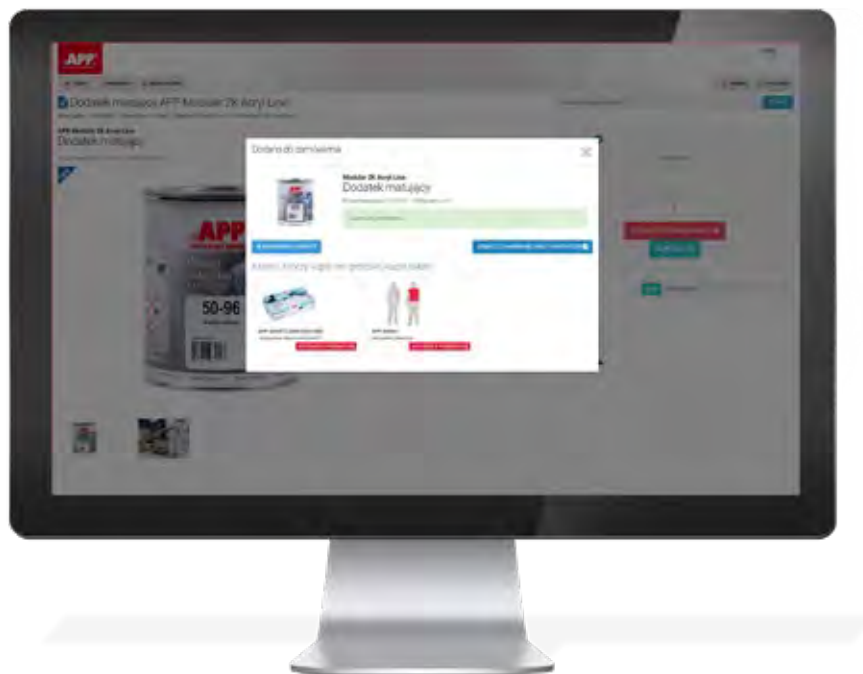

Order
completion
within 3 hours



Price negotiation
PROMOTIONS
DISCOUNTS



Safety of
purchases and
data protection

Your contact at APP

For over 20 years we have been building close Customer relations

Today, APP has over 60 account managers who are ready to support our customer and commercial partners in any situation.

CUSTOMER SERVICE CENTER

Handles all the details related to order performance. Services the helpline.

SALES REPRESENTATIVES / ACCOUNT MANAGERS

Help with selecting the optimal product or service suited to the Customer's needs.

TECHNICAL CONSULTANTS

Prepare training courses regarding products or applications of a new product at the Customer's garage/workshpack.

PRODUCT MANAGERS

Answer all questions regarding product applications.

LOGISTICS DEPARTMENT

Arranges transport to any location in-country and abroad.

over
500
phone calls
per day

over
60
mobile account managers
around the country

nearly
1000
training courses
per year

nearly
200
consultations
daily

400
orders
per day



CUSTOMER SERVICE CENTER

✉ bok@app.com.pl

☎ +48 61 437 00 20

Find a Sales Representative
in your region:
www.APP.com.pl/en/company/page/contact



Technical Support

Consulting and Service

We support our business partners in their everyday work. Our offer includes comprehensive consulting in matters related to car garage operation, technical consultations regarding purchase of electrical, pneumatic machines and dust extraction systems, as well spray guns.

In case of questions concerning a product, service quality or investment process, please contact your Sales Representative, call our helpline, or write to us.



- We offer consulting and servicing also in terms of workshop equipment purchases.



If there is no need for a specialist's visit, we will answer all your questions via telephone or e-mail.



- We will come to your workshop, and together solve the issue on location, demonstrate the product in action, train you and your staff in our products' use.



- We offer full post-sale service combined with a rich training course range in the field of new products and technologies in a state-of-the-art Training Center.



Practical training

Book a course:
www.szkolonia.tech



APP Sp. z o.o. offers a wide range of training courses in auto body and paint repair methods and technologies, Auto Detailing, as well as repairs involving the use of Smart Repair systems. The training course is characterized by high quality based on the knowledge and experience of our trainers. Small groups of no more than three people guarantee intensified practical classes enabling instructions focused on work with the participant at every stage of performing the repair.

/szkolonia.tech

- > **BODYWORK REPAIR**
- > **PAINTING**
- > **AUTO DETAILING**
- > **SMART REPAIRS**

We ensure:

- A highly qualified instructor staff
- A state-of-the-art Training Center
- Products, machines and equipment for practical exercises
- A set of didactic materials
- A meal (Lunch), and refreshments
- Course completion certificates
- Supplies for every course participant



KNOWLEDGE CENTER

certified training
courses tailored
to your needs



Need a training course?
48 605 998 951
szkolonia@app.com.pl





PEŁNA KONTROLA NAD

PACKAGING MONITORING

APP monitors and records the entire product packaging and shipping cycle using HD technology. This allows us to immediately correct any deviations from the agreed standards. Company documentation also forms a basis for complaint processing.



ORDER PERFORMANCE

1

PRODUCT LOCATION TRACING

2

ORDER PREPARATION

3

COMPLIANCE CONTROL

4

PACKING

5

SHIPMENT

ORDER PERFORMANCE

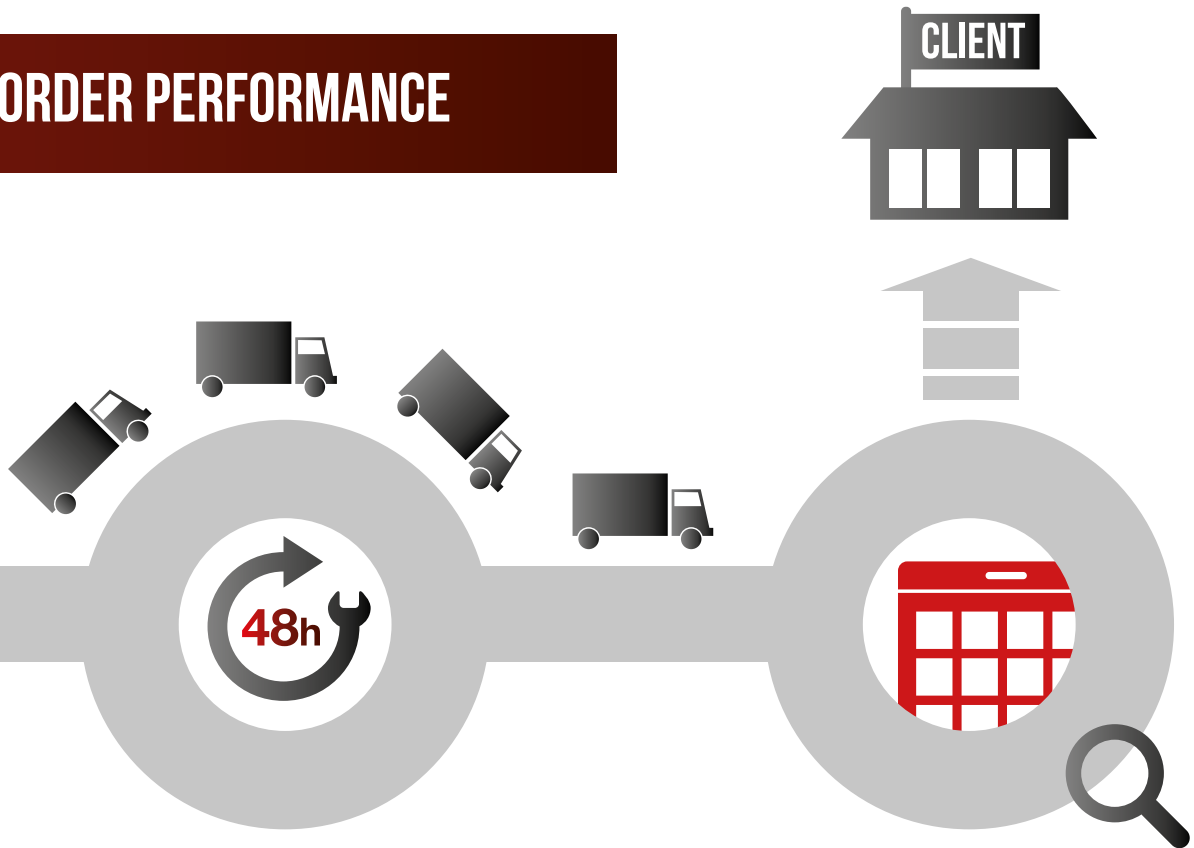

DELIVERY WITHIN 48h

Our logistics competences are confirmed by the fact that as much as 91% of deliveries are executed within 48 h from order placement.

DELIVERY MONITORING

Control is not limited to dispatching the package from the warehouse. The Customer has the ability to monitor the shipment's route and receive information on the time of delivery to the address specified in the order.

COMBINING THE CAPABILITIES OF THE PARTNER AREA AND THE LOGISTICS CENTER CREATES A NEW QUALITY IN ORDER PLACEMENT AND PROCESSING.



APP Logistics Center

Imagine your garage facilities with a space of 15000m² , where any product is always at hand, whenever you need it.

Efficient logistics are the key to APP's success. The XS Logistics central warehouse is a state-of-the-art, fully automated facility. Preparation of the order is done within 3 hours from submission, and the goods reach the Customer within 48 hours.

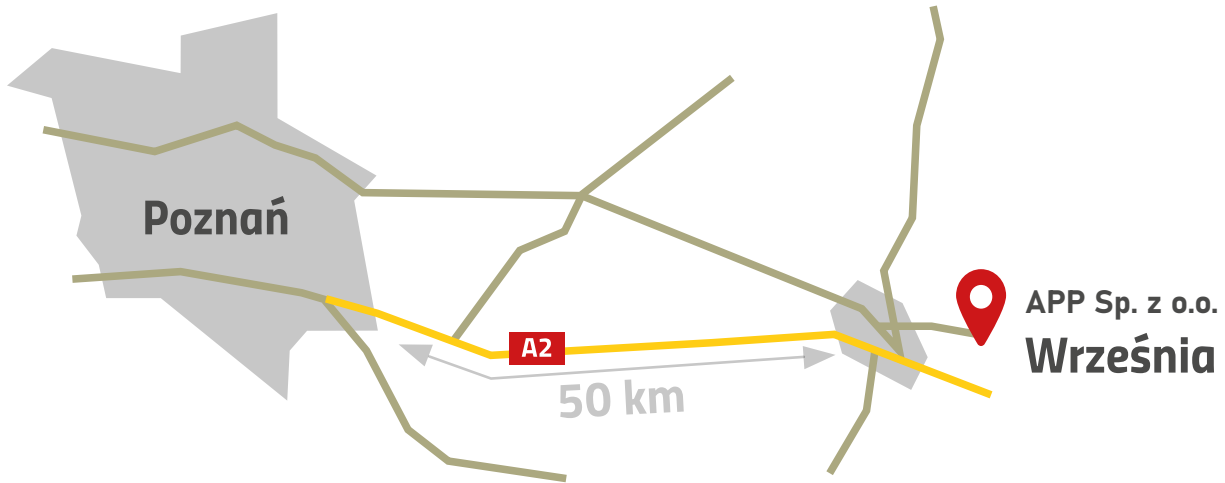

62
employees



15000
pallet locations
in high storage shelving



Monitoring



AWARDING loyal Customers

Register an account in the System
<https://partner.e-app.pl/en>



Individually negotiated prices. We value our Customers and offer them price discounts corresponding to their purchase volume and frequency.



Access to the APP website containing: information on the currently available products, full financial documentation, safe document flow, information on new special offers, new products, and much more.



A modern Partner Program in which we award points for APP product purchases. Points can be exchanged for attractive prizes at any time.



Marketing support. We offer our loyal business partners: garage / workshop branding – advertising materials with the APP logo and promotional stands presenting descriptions of specialized APP services.

Collect points and exchange for awards!



21-232 SPRAY-PAINTING

- 21-28 Putties and fillers
- 29-36 Base and primers
- 37-46 Top coats
- 47-56 Modular color selection system
- 57-62 Thinners, removers and additives
- 63-67 Repair of plastics
- 69-76 Adhesives and sealants
- 77-84 Car body protection and soundproofing
- 85-96 Abrasives
- 97-106 Masking systems
- 107-118 Polishing
- 119-126 OHS
- 127-132 Fabric filters and spray-painting booth accessories
- 133-154 Workshop auxiliary equipment
- 155-170 Various spray-painting products
- 171-178 Spray guns and extruders
- 179-186 Pneumatic grinders
- 187-192 Electric grinders, heat guns and lamps
- 193-198 Work disks
- 199-204 Dust extraction
- 205-208 Radiators
- 209-218 Pneumatics
- 219-222 Spray gun regenerators and washers
- 223-232 Technical sprays

233- 264 AUTO-CARE

- 233 - 238 Washing and cleaning preparations
- 239 - 242 Care and protection preparations
- 243 - 250 Sponges and brushes
- 251- 254 Microfiber cloths
- 255 - 260 Accessories - sprayers, applicators and dosing caps
- 261 - 264 Washing and cleaning devices

265- 304 SMART REPAIR

- 265 - 268 NSK windshield repair
- 269 - 274 Repair and lacquering of leather and plastics
- 275 - 278 Repair of plastic parts damage / welding
- 279 - 304 PDR - Paint-less dent repair
 1. PDR Lamps
 2. Hammers mallets
 3. Glue method - PULL:
 - pullers and inertia hammers
 - suction cups
 - tabs / adapters
 - hot-melt glues
 4. PUSH method:
 - kits
 - push wires
 - PDR accessories
 - stands, cards

305- 351 BODYWORK REPAIR

- 305 - 306 Panel repair sets
- 307 - 312 Spotters and accessories
- 313 - 318 Consumables for spotters: electrodes, rivets, triangles
- 319 - 320 Welding: wires, nozzles, grips
- 321 - 324 Panel repair tongs
- 325 - 328 Spreaders, pullers and clamps
- 329 - 342 Specialized body repair tools
- 343 - 348 Car body repair - non-invasive methods
- 349 - 351 Welding: OHS

find us:



SPRAY-PAINTING



Putties and fillers

21-232 SPRAY -PAINTING

- 21-28 • Putties and fillers**
- 29-36 Base and primers
- 37-46 Top coats
- 47-56 Modular color selection system
- 57-62 Thinners, removers and additives
- 63-67 Repair of plastics
- 69-76 Adhesives and sealants
- 77-84 Car body protection and soundproofing
- 85-96 Abrasives
- 97-106 Masking systems
- 107-118 Polishing
- 119-126 OHS
- 127-132 Fabric filters and spray-painting booth accessories
- 133-154 Workshop auxiliary equipment
- 155-170 Various spray-painting products
- 171-178 Spray guns and extruders
- 179-186 Pneumatic grinders
- 187-192 Electric grinders, heat guns and lamps
- 193-198 Work disks
- 199-204 Dust extraction
- 205-208 Radiators
- 209-218 Pneumatics
- 219-222 Spray gun regenerators and washers
- 223-232 Technical sprays

• APP SN 05 Spray filler

VOC/LZO 2004/42/EC - II B (b)(250): <116 g/l

APP SN-05 is a two-component spray-on filler based on polyester resin and mineral fillers. It is intended for application using the spray method onto previously prepared, large surfaces. The filler has very good filling properties. It dries fastly and is easy to grind.

➤ ADVANTAGES

- ability to apply thick layers
- short bonding time
- easy to process after curing

APP NO.	Packaging	Description	Volume	Pack.
010501	can	with hardener	1 kg	1 pcs.

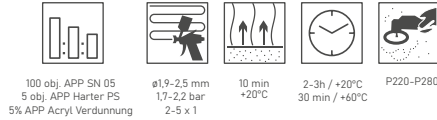

• APP Ultra Universal filler

VOC/LZO 2004/42/EC - II B (b)(250): 25 g/l

APP Ultra is a two-component, polyester filler putty with a density of 1,30 kg/dm³ for filling dents and evening out scratches in car body repairs. The putty uses a synthetic glass micro-filler that reduces its weight, decreasing the force needed for extraction and eliminating the occurrence of holes.

➤ ADVANTAGES

- easy to process after hardening
- does not leave holes
- hardens in a wide range of temperatures
- slightly increases the weight of filled elements
- can be used on zinc coated steel and typical plastic elements

APP NO.	Packaging	Volume	Col. pack.
010406	can	0,5 L	8 pcs.
010407	can	1 L	8 pcs.
010408	can	3 L	8 pcs.
010409	cartouche	1,6 L	8 pcs.



• APP Supra Universal filler

VOC/LZO 2004/42/EC - II B (b)(250): <220 g/l

APP Supra is a fast-drying, two-component, polyester filler putty with a moderate density of 1,30 kg/dm³. The creamy consistency of the filler allows for very easy application on surfaces with complex shapes. The minor shrinkage during curing enables the filler to be used on large surfaces.

➤ ADVANTAGES

- high quality of the sanded surface (no holes)
- excellent transition quality between the filler and substrate
- minor shrinkage while curing
- low moisture permeability
- very good adhesion to difficult substrates, e.g. zinc-coated steel sheet, aluminum
- very easy to apply and process

APP NO.	Packaging	Description	Volume	Col. pack.
010320	can	with hardener	1 L	6 pcs.



• APP Compact Universal filler

VOC/LZO 2004/42/EC - II B (b)(250): <220 g/l

APP Compact is a fast-drying, two-component polyester filler putty with density decreased to 1,0 kg/dm³. The filler is characterized by good filling of both small and large paintwork defects. It is easy to apply and process.

> ADVANTAGES

- decreased putty density does not cause increased weight of the repaired element
- low moisture permeability
- good adhesion to difficult substrates, e.g. zinc coated steel sheet or aluminum
- easy to process both manually and mechanically



APP NO.	Packaging	Description	Volume	Col. pack.
010120	can	with hardener	1 L	6 pcs.



2-3 % 3-5 min +20°C P120-P320 15-25 min +20°C 4-5 min

• APP Premia Universal filler

VOC/LZO 2004/42/EC - II B (b)(250): 50 g/l

APP Premia is a multifunctional, two-component, polyester filler putty. Thanks to its creamy consistency, it is easy to apply and model, also on surfaces with complex shapes. It is intended for filling out dents and leveling scratches during car body repairs and finishing works.

> ADVANTAGES

- easy to apply on large surfaces
- allows shape formation during application
- easy to process after hardening



APP NO.	Packaging	Description	Volume	Col. pack.
010310	can	with hardener	1,8 kg	8 pcs.
010309	can	with hardener	0,6 kg	12 pcs.



2-3 % 4-5 min +20°C P80-P280 20-25 min +20°C 5 min max +80°C

• APP Fiber Filler with fiberglass

VOC/LZO 2004/42/EC - II B (b)(250): <249 g/l

APP Fiber is a polymer, two-component filler reinforced with short fiberglass. It is intended for repairing areas weakened by corrosion and locations exposed to high mechanical stress, for filling large unevenness and smaller holes, and stabilizing the substrate. It features increased mechanical strength.

> ADVANTAGES

- easy to apply on large surfaces
- curing in a wide range of temperatures
- increased mechanical strength
- high stability over time
- easy to process after curing



APP NO.	Packaging	Description	Volume	Col. pack.
010210	can	with hardener	140 ml	12 pcs.
010211	can	with hardener	420 ml	12 pcs.
010212	can	with hardener	1200 ml	6 pcs.



2-3 % 5 min +20°C P60-P120 20-30 min +20°C 7-14 min

• APP Fiber Light

Filler with fiberglass

VOC/LZO 2004/42/EC - II B (b)(250): 178,3 g/l

APP Fiber Light is a polyester, two-component putty with increased elasticity with a micro-fine type filler, reinforced with short fiberglass with a density of 1,22 kg/dm³. It is intended for areas weakened by corrosion and locations exposed to high mechanical stress.

➤ ADVANTAGES

- easy to apply and process.
- curing in a wide range of temperatures.
- high mechanical resistance.
- minor shrinkage.
- ability to work on large fillings.
- slightly increases the weight of filled elements.



APP NO.	Packaging	Description	Volume	Pack.
010215	can	with hardener	1000 ml	6 pcs.



• APP Alu

Filler putty with aluminum dust

VOC/LZO 2004/42/EC - II B (b)(250): 245,6 g/l

APP Alu is a two-component, polyester filler putty with an addition of aluminum dust. It is intended for evening out scratches and stabilizing large surfaces, on which it is very easy to distribute. It has increased mechanical resistance. Thermal resistance up to 120°C.

➤ ADVANTAGES

- easy to apply on large surfaces
- curing in a wide range of temperatures
- increased mechanical strength
- high stability over time



APP NO.	Packaging	Description	Volume	Col. pack.
010223	can	with hardener	0,6 kg	12 pcs.
010225	can	with hardener	1,8 kg	6 pcs.

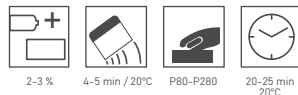

• APP PE Poly Plast

Universal filler

VOC/LZO 2004/42/EC - II B (b)(250): <249 g/l

APP PE Poly Plast is a two-component, polyester filler putty with a medium grain and medium elasticity, used for filling dents and evening out scratches during car body repairs. It is characterized by very good adhesion to steel, aluminum, polyester laminates, as well as wood and concrete.

➤ ADVANTAGES

- curing in a wide range of temperatures
- increased mechanical strength
- high stability over time
- variety of packages



APP NO.	Packaging	Description	Volume	Col. pack.
010106	can	with hardener	0,2 kg	12 pcs.
010107	can	with hardener	0,6 kg	12 pcs.
010104	cartouche	with hardener	3 kg	6 pcs.
010105	can	with hardener	6 kg	-

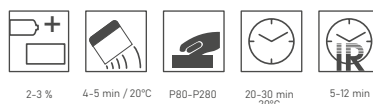

• APP 1K S

Smoothing filler putty

VOC/LZO 2004/42/EC - II B (c)(540): <539 g/l

APP 1K S is a one-component, fine-grain smoothing filler putty for filling very small, point defects and scratches in previously prepared substrates. The putty ensures durable filling on plastic surfaces. It can be covered with acrylic top coats.

➤ ADVANTAGES

- łatwa w nakładaniu
- przyczepność do wielu podłoży z tworzywami sztucznymi włącznie
- nie wymaga izolacji podkładem przed lakierowaniem



APP NO.	Packaging	Volume	Pack.
010602	tube	0,1 kg	12 pcs.



• APP Fast Repair

Repair set: resin + mat

VOC/LZO 2004/42/EC - II B (b)(250): <250 g/l

APP Fast Repair is a laminating repair set. It is intended for filling large material defects, metal surface perforations, as well as strengthening areas weakened by corrosion. The repair set consists of a polyester resin, a curing agent paste, and a fiberglass mat.

➤ ADVANTAGES

- easy to use
- allows to rebuild missing fragments
- hardens in a wide range of temperatures
- high mechanical resistance
- high resistance to oscillations and vibrations



APP NO.	Packaging	Volume	Col. pack.
010702	can	0,25 kg	6 pcs.

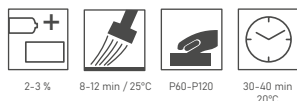

• APP Reparatur Box

Repair set: resin + fabric

VOC/LZO 2004/42/EC - II B (b)(250): <249 g/l

APP Reparatur Box is a laminating repair set. It is intended for filling large material defects, metal surface perforations, as well as strengthening areas weakened by corrosion. The repair set consists of a polyester resin, a curing agent paste, and a fiberglass mat.

➤ ADVANTAGES

- easy to use
- allows to rebuild missing fragments
- hardens in a wide range of temperatures
- high mechanical resistance
- high resistance to oscillations and vibrations



APP NO.	Packaging	Volume	Col. pack.
010701	can	0,25 kg	6 pcs.

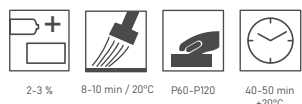



ADVANTAGES

- 01** fast-drying
- 02** multifunctional
- 03** no holes
- 04** very good adhesion to difficult substrates, e.g. zinc-coated steel sheet
- 05** the incorporated micro-filler allows to obtain a high quality sanded surface

• APP QUARTZ Q102 Universal filler

The APP QUARTZ Q102 is a high quality polyester putty with the qualities of a filler and finishing putty. Thanks to the incorporation of a micro-filler in combination with a modern formula, the putty ensures a smooth, non-porous surface and high durability of the performed repair.

It is characterized by a creamy consistency, is very easy to apply and process, both manually and mechanically.



see more
about the product



VOC/LZO 2004/42/EC - II B (b)(250): <12 g/l

APP NO.	Packaging	Volume	Col. pack.
010420	can	1 L	8 pcs.



2-3 % 3-5 min +20°C P120-P320 20-25 min +20°C 4-5 min max +80°C

• APP Polylam Polyester laminating resin

VOC/LZO 2004/42/EC - II B (b)(250): <249 g/l

APP Polylam is a chemically hardened, medium elasticity polyester resin intended for manual lamination during car body repairs. After curing, in combination with a fabric or fiberglass mat, it features high resistance to mechanical stress, vibrations and oscillations. It is also resistant to oils, grease and petrol.

▶ ADVANTAGES

- easy to use.
- allows to rebuild missing fragments.
- hardens in a wide range of temperatures.
- high mechanical resistance.
- high resistance to oscillations and vibrations.

APP NO.	Packaging	Volume	Col. pack.
010801	can	1 L	6 pcs.

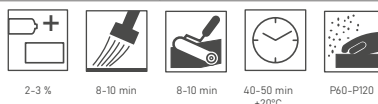

• APP MS 300 Fiberglass mat

APP MS 300 is a fiberglass mat manufactured from non-oriented, cut fiberglass with a length of 50 mm, glued using an emulsion binder. It is intended for manual lamination using a chemically hardened polyester resin. After curing, the laminate is characterized by high resistance to mechanical stress, oscillations and vibrations. Dimensions: 1250 mm x 400 mm (0,5 m²). Area density: 300 g/m².

▶ ADVANTAGES

- easy to use
- allows to rebuild missing fragments
- high mechanical resistance
- high resistance to oscillations and vibrations
- laminate more susceptible to forming complex shapes than fabric

APP NO.	Option	Weight / Size	Col. pack.
010903	300 g/m ²	0,5 m ²	40 pcs.



• APP TS 400 Glass fabric

APPTS 400 is a glass fabric manufactured from strands of fiberglass with a uniform warp and weft. It is intended for manual lamination using a chemically hardened polyester resin. After curing, the laminate is characterized by high resistance to mechanical stress, oscillations and vibrations. Dimensions: 1000 mm x 500 mm (0,5 m²). Area density: 400 g/m².

▶ ADVANTAGES

- easy to use
- allows to rebuild missing fragments
- hardens in a wide range of temperatures
- high mechanical resistance
- high resistance to oscillations and vibrations
- laminate more mechanically resistant than laminate from a mat

APP NO.	Option	Weight / Size	Col. pack.
010904	400 g/m ²	0,5 m ²	40 pcs.



• APP Harter Paste Filler and polyester resin curing agent in a tube

APP Harter Paste is a universal, peroxide-based curing agent in the form of paste, intended for polyester products such as polyester filler putty and polyester resin. It is available in tube type packaging.

APP NO.	Type	Weight / Size
010526	utwardzacz w tubie do szpachli	50 g



SPRAY-PAINTING

1



Base and primers

21-232 LAKIERNICTWO

- 21-28 Putties and fillers
- 29-36 • Base and primers**
- 37-46 Top coats
- 47-56 Modular color selection system
- 57-62 Thinners, removers and additives
- 63-67 Repair of plastics
- 69-76 Adhesives and sealants
- 77-84 Car body protection and soundproofing
- 85-96 Abrasives
- 97-106 Masking systems
- 107-118 Polishing
- 119-126 OHS
- 127-132 Fabric filters and spray-painting booth accessories
- 133-154 Workshop auxiliary equipment
- 155-170 Various spray-painting products
- 171-178 Spray guns and extruders
- 179-186 Pneumatic grinders
- 187-192 Electric grinders, heat guns and lamps
- 193-198 Work disks
- 199-204 Dust extraction
- 205-208 Radiators
- 209-218 Pneumatics
- 219-222 Spray gun regenerators and washers
- 223-232 Technical sprays

• APP AcrylFiller Multi Sanding

Two-component acrylic filler base 5:1

VOC/LZO 2004/42/EC- II B (c)(540): 408,3 g/l

APP AcrylFiller Multi Sanding is a two-component, HS class acrylic filler base with a high solid particle Volume, low absorptivity and short drying time. It is characterized by excellent adhesion to steel, polyester filler putties and old paint coats. It is intended for work using the classic method with grinding. Available in three colors: grey, black and white.

➤ ADVANTAGES

- short drying time
- very good spreading properties and easy processing
- high tightness of the dry coating
- possibility of dry grinding after 3 hours in +20°C
- ability to cover with water-dilutable and organic (conventional) paints
- universal application for repairs with filling and on primed new car body panels
- compatible with curing agents in the APP AcrylFiller Multi series and APP Acryl Verdunnung thinners



AcrylFiller Multi Sanding

Two-component acrylic filling base

APP NO.	Packaging	Color	Volume	Col. pack.
020470	can	black	1,0 L	12 pcs.
020471	can	grey	1,0 L	12 pcs.
020472	can	white	1,0 L	12 pcs.
020473	can	black	4,0 L	2 pcs.
020474	can	grey	4,0 L	2 pcs.
020475	can	white	4,0 L	2 pcs.

Harter AcrylFiller Multi

Acrylic base curing agent

APP NO.	Packaging	Type	Volume	Col. pack.
020534	can	normal	0,2 L	12 pcs.
020535	can	normal	0,8 L	6 pcs.
020536	can	fast	0,2 L	12 pcs.
020537	can	fast	0,8 L	6 pcs.



5 obj. APP AcrylFiller Multi Sanding
1 obj. APP Harter AcrylFiller Multi
0-20% APP Acryl Verdunnung



20-52 s
4 mm DIN
+20°C



> 30 min
+20°C



ø1,5-1,8 mm
2-3 bar
2-3 x 1



7-10 min
+20°C



3 h / +20°C
20-30 min / +60°C
9-12 min / IR



P320-P500

• APP AcrylFiller Multi Wet on Wet

Two-component non sanding filler wet on wet

VOC/LZO 2004/42/EC- II B (c)(540): 339 g/l

APP AcrylFiller Multi Wet on Wet is an essential product in any paint shpack. It is intended for work in a wet on wet system, allowing to save plenty of time during painting of new elements. It can be used with all APP AcrylFiller line hardening agents and APP Acryl Verdunnung thinners. After application and evaporation, it has a very smooth surface. The product provides a stable base for applying top coats without altering the structure or causing loss of colorless paint gloss. The APP Acryl Filler Wet on Wet is available in grey and dark grey. It can be used under water-soluble and organic (conventional) base and top coats, as well as acrylic coats.

➤ ADVANTAGES

- short drying time- bardzo dobra rozlewność
- very good flow
- high coating tightness
- smooth surface and stable coating
- limitation of stocks
- reduced risk of error. increased paint shop efficiency
- ability to obtain several shades of grey



AcrylFiller Multi Wet on Wet

Two-component acrylic filling base Wet on Wet

APP NO.	Packaging	Color	Volume	Col. pack.
020460	can	grey	1,0 L	12 pcs.
020461	can	dark grey	1,0 L	12 pcs.
020462	can	grey	4,0 L	2 pcs.
020463	can	dark grey	4,0 L	2 pcs.

Harter AcrylFiller Multi

Acrylic base curing agent

APP NO.	Packaging	Type	Volume	Col. pack.
020534	can	normaln	0,2 L	12 pcs.
020535	can	normaln	0,8 L	6 pcs.
020536	can	fast	0,2 L	12 pcs.
020537	can	fast	0,8 L	6 pcs.



5 obj. APP AcrylFiller Multi Wet on Wet
1 obj. APP Harter AcrylFiller Multi
20-30% APP Acryl Verdunnung



17-20 s
4 mm DIN
+20°C



45 min
+20°C



ø1,2-1,4 mm
2-3 bar
1 x 1



20-30 min
+20°C



• APP AcrylFiller 401

Two-component acrylic filling base 4:1

VOC/LZO 2004/42/EC- II B (c)(540): <540 g/l

APP AcrylFiller 401 is a two-component, High Solid class, acrylic filler base. The formula guarantees very high adhesion to steel, polyester products, and old paint coats, as well as provides increased coverage and insulation properties. **It is intended undercoating using the classic method with grinding, and for work in a wet on wet system.**

AcrylFiller 401
Two-component acrylic filling base

APP NO.	Packaging	Color	Volume	Col. pack.
020415	can	black	1,0 L	12 pcs.
020416	can	grey	1,0 L	12 pcs.
020417	can	white	1,0 L	12 pcs.
020418	can	black	4,0 L	4 pcs.
020419	can	grey	4,0 L	4 pcs.
020420	can	white	4,0 L	4 pcs.

Harter AcrylFiller 401
Utwardzacz do podkładu akrylowego

APP NO.	Packaging	Type	Volume	Col. pack.
020518	can	normal	1,0 L	6 pcs.
020520	can	normal	0,25 L	12 pcs.
020519	can	fast	1,0 L	6 pcs.
020521	can	fast	0,25 L	12 pcs.

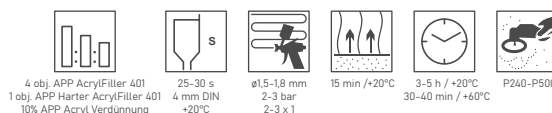

ADVANTAGES

- 01** very tight insulation layer
- 02** possibility of wet on wet work
- 03** allows creation of spectral greys
- 04** easy dry processing after curing
- 05** packaging fitted to agitators in mixers



see more about the product



• APP AcrylFiller 501

Two-component acrylic filling base 5:1

VOC/LZO 2004/42/EC- II B (c)(540): <540 g/l

APP AcrylFiller 501 is a thick-layer, two-component, High Solid class filling base characterized by excellent adhesion to steel, polyester filler putty and old top coat paints, and good adhesion to zinc coated steel. A very high solid substance Volume enables application of thick layers without the risk of coating cracking.

➤ ADVANTAGES

- very low thinner Volume
- short evaporation and drying time
- ability to apply very thick layers
- good adhesion to zinc coated steel
- easy to process when dried and cured
- packaging fitted to agitators in mixers



AcrylFiller 501

Two-component acrylic filling base

APP NO.	Packaging	Color	Volume	Col. pack.
020407	can	white	1,0 L	12 pcs.
020408	can	grey	1,0 L	12 pcs.
020409	can	black	1,0 L	12 pcs.
020410	can	white	4,0 L	4 pcs.
020411	can	grey	4,0 L	4 pcs.
020412	can	black	4,0 L	4 pcs.



Harter AcrylFiller 501

Acrylic base curing agent

APP NO.	Packaging	Type	Volume	Col. pack.
020506	can	normal	0,2 L	12 pcs.
020508	can	normal	0,8 L	6 pcs.
020507	can	fast	0,2 L	12 pcs.
020509	can	fast	0,8 L	6 pcs.



• APP AcrylFiller Rapid

Two-component acrylic filling base 4:1

VOC/LZO 2004/42/EC- II B (c)(540): 535 g/l

APP AcrylFiller Rapid is a fast, two-component, High Solid class filler base characterized by excellent adhesion to polyester filling putty, primers and fillers, and old paint coats. It is easy to grind, guarantees maximum adhesion to the top coat paint, as well as gloss and stability over time.

➤ ADVANTAGES

- very good spreading properties
- short drying and evaporation time
- ability to work in difficult conditions (low temperature)
- easy processing after curing
- packaging fitted to agitators in mixers



AcrylFiller Rapid

Two-component acrylic filling base

APP NO.	Packaging	Color	Volume	Col. pack.
020425	can	white	1,0 L	12 pcs.
020426	can	grey	1,0 L	12 pcs.
020427	can	black	1,0 L	12 pcs.
020428	can	white	4,0 L	4 pcs.
020429	can	grey	4,0 L	4 pcs.
020430	can	black	4,0 L	4 pcs.



Harter AcrylFiller Rapid

Acrylic base curing agent

APP NO.	Packaging	Type	Volume	Col. pack.
020528	can	normal	0,25 L	12 pcs.
020530	can	normal	1,0 L	6 pcs.
020529	can	fast	0,25 L	12 pcs.
020531	can	fast	1,0 L	6 pcs.

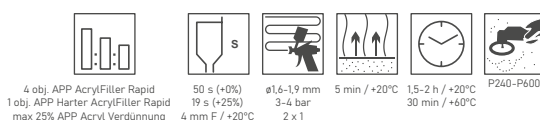

• APP AcrylFiller Compact

Two-component acrylic filler base 5:1

VOC/LZO 2004/42/EC- II B (c)(540): 502 g/l

PP AcrylFiller Compact is a two-component, High Solid class filler base with excellent adhesion to steel, polyester filler putty, and old paint coats. Its high solid substance Volume enables application of thick layers without the risk of coat cracking. The product has high density inside the packaging, requires use of a thinner.

➤ ADVANTAGES

- universal application
- fine grain filler facilitates in concealing transitions
- product intended for use during less involved works



AcrylFiller Compact

Two-component acrylic filling base

APP NO.	Packaging	Color	Volume	Col. pack.
020444	can	grey	0,83 L	12 pcs.
020445	can	ciemnogyrey	0,83 L	12 pcs.



Harter AcrylFiller Compact

Acrylic base curing agent

APP NO.	Packaging	Type	Volume	Col. pack.
020504	can	normal	0,17 L	12 pcs.

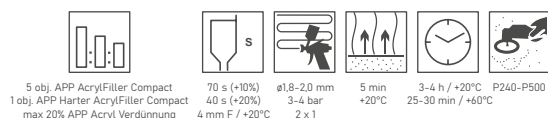

• APP Grund EP

Two-component epoxy primer 3:1

VOC/LZO 2004/42/EC- II B (c)(540): <540 g/l

APP Grund EP is a two-component, chromate-less, epoxy filling primer with zinc phosphate. It is intended for corrosion protection. It is characterized by very good adhesion to steel, zinc coated steel, aluminum, fiberglass reinforced plastics, and mineral substrates. It can be used classic applications with grinding, for wet on wet methods, and as an adhesion primer and insulator.

➤ ADVANTAGES

- excellent anti-corrosion properties
- coating with very high tightness
- good insulator that prevents mapping
- work in a wet on wet system
- very good adhesion to various substrates



APP NO.	Packaging	Color / Type	Volume	Col. pack.
021201	can	light grey	1,0 kg	6 pcs.
021202	can	curing agent	0,2 kg	12 pcs.

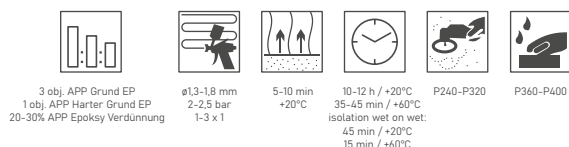

• APP Grund Epoxy Spray

Epoxy primer

VOC/LZO 2004/42/EC- II B (c)(780): 683,4 g/l

APP Grund Epoxy Spray is a fast-drying epoxy primer intended for insulation and corrosion protection. Thanks to incorporating high quality epoxy resin, the base features very good adhesion to iron, steel, zinc coated steel and aluminum. It can be covered by all types of top coat paints.

➤ ADVANTAGES

- very good insulating properties
- after grinding, small surfaces can be covered with a polyester putty, base, and top coat paints
- nozzle with a wide, elliptical stream shape, similar to a small spray-painting gun
- can be used in a wet on wet work system
- fast-drying, can be sanded 30 minutes after application
- includes anti-corrosion additives



APP NO.	Packaging	Color	Volume	Col. pack.
021205	aerosol	light grey	500 ml	6 pcs.
021206	aerosol	ciemnogyrey	500 ml	6 pcs.

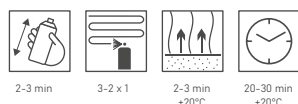

• APP 2K Haftgrund

Two-component, acid-hardened, reactive primer 2:1

VOC/LZO 2004/42/EC- II B (c)(780): 644 g/l

APP 2K Haftgrund is a two-component, acidic, anti-corrosion wash primer. It is intended for active corrosion protection during vehicle body repairs. It is characterized by very good adhesion to iron, steel, and good adhesion to nonferrous metals, e.g. soft aluminum. The product includes zinc orthophosphate. The primer should not be covered with polyester products.

➤ ADVANTAGES

- work in a wet on wet system
- guaranteed adhesion to various substrates
- very good corrosion protection

APP NO.	Packaging	Color / Type	Volume	Col. pack.
020610	can	grey	1 L	6 pcs.
020620	bottle	curing agent	0,5 L	6 pcs.

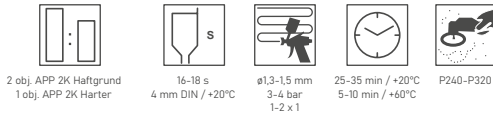

• APP Haftgrund

One-component reactive primer

VOC/LZO 2004/42/EC- II B (c)(780): 634 g/l

APP Haftgrund is a one-component wash primer intended for active corrosion protection of passenger, delivery, commercial vehicle and bus bodyworks. It is characterized by very good adhesion to degreased and sanded surfaces made from steel, zinc coated steel and aluminum sheets. The product is intended for priming using the classic method with grinding and for work in the wet on wet system. The primer should not be covered with polyester products.

➤ ADVANTAGES

- universal application
- work in a wet on wet system
- guaranteed adhesion to various substrates including zinc coated steel
- very good corrosion protection
- weldability certificate dvs 0501 no.: 275/670/99/925

APP NO.	Packaging	Color	Volume	Col. pack.
020601	can	red-brown	1 L	6 pcs.

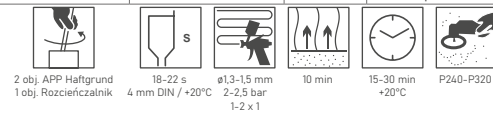

• APP Haftgrund Spray

Reactive primer

VOC/LZO 2004/42/EC- II B (e)(840): 666 g/l

APP Haftgrund Spray is a one-component wash primer intended for active corrosion protection of passenger, delivery, commercial vehicle and bus bodyworks. It is characterized by very good adhesion to degreased and sanded surfaces made from steel, zinc coated steel and aluminum sheets. The product is intended for priming using the classic method with grinding and for work in the wet on wet system. The primer should not be covered with polyester products.

➤ ADVANTAGES

- universal application
- work in a wet on wet system
- guaranteed adhesion to various substrates including zinc coated steel
- very good corrosion protection
- weldability certificate 0501 no.: 275/670/99/925

APP NO.	Packaging	Color	Volume	Col. pack.
020605	aerosol	red-brown	400 ml	12 pcs.

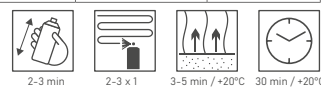

• APP R STOP

Anti-corrosion agent

VOC/LZO 2004/42/EC- II B(e)(840): 751,5 g/l

APP R Stop is a penetrating anti-corrosion agent that halts the development of corrosion. When applied on a surface cleaned of flash rust, it removes moisture from corrosion centers (pits) and isolates them. The product is ready to use and prepared for application with a brush or spray gun. The impregnated surfaces can be covered with polyester products as well as 1- and 2-component bases. The product is reactive to moisture. Tightly close the packaging immediately after use.

➤ ADVANTAGES

- product ready to use
- penetrating preparation with very low viscosity
- small package – the product is highly reactive to ambient humidity

APP NO.	Packaging	Volume	Col. pack.
021100	can	100 ml	6 pcs.

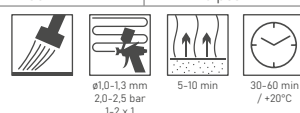

• APP Primer Filler

One-component, anti-corrosion filler primer

APP Primer Filler is a fast-drying, one-component filler primer with active corrosion protection. It is characterized by very good adhesion to iron, steel, zinc coated steel and aluminum, and certain plastic materials. It can be covered with all types of top coat paints.

➤ ADVANTAGES

- ability to work in a wet on wet system
- includes anti-corrosion additives
- packaging fitted to agitators in mixers

APP NO.	Packaging	Color	Volume	Col. pack.
020710	can	dark grey	1 L	6 pcs.
020711	can	light grey	1 L	6 pcs.

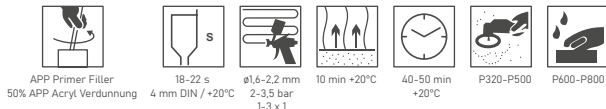

• APP Primer Filler Spray

One-component, anti-corrosion filler primer

The anti-corrosive APP Primer Filler is a fast-drying, one-component filler primer with active corrosion protection. It features very good adhesion to iron, steel, zinc coated steel and aluminum, and certain plastic materials. It can be covered with all types of top coat paints.

APP Primer Filler Spray is a fast-drying, one-component filler primer with active corrosion protection. It features very good adhesion to iron, steel, zinc coated steel and aluminum, and certain plastic materials. It can be covered with all types of top coat paints.

APP Primer Filler Spray is intended for priming minor regrinds and for micro-repair systems.

➤ ADVANTAGES

- ability to work in a wet on wet system
- includes anti-corrosion additives
- easy to use

APP NO.	Packaging	Color	Volume	Col. pack.
020720	aerosol	dark grey	400 ml	12 pcs.
020721	aerosol	light grey	400 ml	12 pcs.

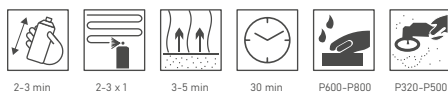

• APP Smart Primer Spray

Insulating primer

APP Smart Primer Spray is a fast-drying, one-component, insulating and filling primer. It is characterized by good adhesion to polyester fillers, paint coats and metal. The primer is easy to grind. It guarantees very high adhesion and stability of the applied top coat. It is intended for priming minor regrinds and for micro-repair systems.

➤ ADVANTAGES

- very good insulator
- color compatible with the grey APP AcrylFiller 501
- very good adhesion to various substrates
- short drying time

APP NO.	Packaging	Color	Volume	Col. pack.
020590	aerosol	grey	400 ml	6 pcs.

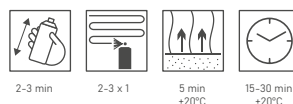

• APP Rally Haftgrund Spray

Acrylic primer

VOC/LZO 2004/42/EC- II B (e)(840): 676,1 g/l

APP Rally Haftgrund Spray is a fast-drying, one-component, insulating and filling primer. It is characterized by good adhesion to polyester fillers and paint coats. The formula guarantees very good adhesion to steel and aluminum. The primer is easy to grind. It can be covered with all types of finishing lacquers.

➤ ADVANTAGES

- universal application
- easy to use
- easy grinding after curing

APP NO.	Packaging	Color	Volume	Col. pack.
210106	aerosol	grey	600 ml	6 pcs.
210116	aerosol	grey	600 ml	6 pcs.

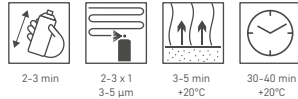

• APP Kunststoff Primer

Plastic material primer

VOC/LZO 2004/42/EC- II B (c)(780): 679 g/l

APP Kunststoff Primer, APP Kunststoff Primer Spray and APP Kunststoff Primer Transparent are elastic, fast-drying, one-component primers that increase the adhesion of bases and top coats to plastic surfaces. They are intended for use with elements from plastics such as: ABS, EP laminate, PA, PBTP, PC, POM, PP/EPDM, PPO, hard PUR, soft PUR and PVC

➤ ADVANTAGES

- work in a wet on wet system
- universal application for many substrates
- product ready to spray

APP NO.	Packaging	Color	Volume	Col. pack.
020901	can	transparent / silver	1 L	6 pcs.
020902	can	transparent	1 L	6 pcs.
020905	aerosol	transparent / silver	400 ml	12 pcs.

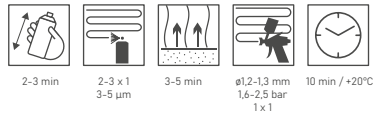

• APP Kunststoff Ref Primer Spray

Plastic material primer

VOC/LZO 2004/42/EC- II B (c)(780): 713,7 g/l

Plastic material primer is an elastic, fast-drying, one-component primer that increases the adhesion of bases and top coats to plastic surfaces. It is intended for use on polycarbonate (PC) headlight globes and elements from plastic materials such as: ABS, EP laminate, PA, PBTP, PC, POM, PP/EPDM, PPO, hard PUR, soft PUR and PVC.

➤ ADVANTAGES

- completely colorless and transparent
- creates a uniform adhesive layer on a PC headlight globe – does not crack on polycarbonate
- work in a wet on wet system
- universal application for many substrates
- product ready to spray

APP NO.	Packaging	Color	Volume	Col. pack.
020906	aerosol	transparent	400 ml	12 pcs.

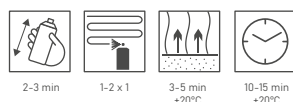

SPRAY-PAINTING

1



Top coats

21-232 SPRAY-PAINTING

- 21-28 Putties and fillers
- 29-36 Base and primers
- 37-46 • Top coats**
- 47-56 Modular color selection system
- 57-62 Thinners, removers and additives
- 63-67 Repair of plastics
- 69-76 Adhesives and sealants
- 77-84 Car body protection and soundproofing
- 85-96 Abrasives
- 97-106 Masking systems
- 107-118 Polishing
- 119-126 OHS
- 127-132 Fabric filters and spray-painting booth accessories
- 133-154 Workshop auxiliary equipment
- 155-170 Various spray-painting products
- 171-178 Spray guns and extruders
- 179-186 Pneumatic grinders
- 187-192 Electric grinders, heat guns and lamps
- 193-198 Work disks
- 199-204 Dust extraction
- 205-208 Radiators
- 209-218 Pneumatics
- 219-222 Spray gun regenerators and washers
- 223-232 Technical sprays



ADVANTAGES



- 01 short lacquer drying time
- 02 high gloss
- 03 easy application on large surfaces
- 04 ability to adjust the lacquer's structure through the addition of an acrylic thinner
- 05 easy to polish



• APP Klarlack Glosser

Colorless, two-component acrylic lacquer 2:1

APP Klarlack Glosser is a two-component, colorless, HS class acrylic lacquer with a high gloss, that maintains stability over time. It is easy to apply over large surfaces, as well as polish. **The lacquer's short drying time makes it possible to reduce the time needed for repairing individual elements and entire vehicles.**

SHORT DRYING TIME

Allows to reduce the time need for repairing individual elements and entire vehicles

Ready to work in a temp.
 +20°C - 2,5 hours
 +60°C - 15 min
 IR 10 container - 15 min



APP Klarlack Glosser clear lacquer is resistant to weather conditions in different climate zones.

Three hardener types are available Free, Normal and Fast drying one to ensure optimal work effects at the given ambient temperature and area of surface.

see more about the product



VOC/LZO: 2004/42/EC - II B (e)(840): 450,3 g/l

Klarlack Glosser
Colorless, two-component acrylic lacquer

APP NO.	Packaging	Color	Volume	Col. pack.
020121	can	colorless	1,0 L	6 pcs.
020122	can	colorless	5,0 L	4 pcs.

Harter Klarlack Glosser
Acrylic lacquer curing agent

APP NO.	Packaging	Type	Volume	Col. pack.
020348	can	free	0,5 L	6 pcs.
020349	can	free	2,5 L	4 pcs.
020350	can	normal	0,5 L	6 pcs.
020351	can	normal	2,5 L	4 pcs.
020352	can	fast	0,5 L	6 pcs.
020353	can	fast	2,5 L	4 pcs.



2 obj. APP Klarlack Glosser
1 obj. APP Harter Klarlack Glosser
5-15% APP Acryl Verdünnung



16-17 s
4 mm DIN
+20°C



ø1,2-1,3 mm
2,5-3,5 bar
2 x 1



10-15 min
+20°C



1,5-2h / +20°C
15 min / +60°C

• APP Klarlack S Pro

Two-component, acrylic colorless lacquer 2:1

VOC/LZO 2004/42/EC- II B (e)(840): <493 g/l

APP Klarlack S Pro is a two-component, colorless, HS class acrylic lacquer with a high gloss factor. It is characterized by very good flow properties and clarity, which allows to obtain great color depth. The lacquer's quick drying enables significant reduction of the time required to repair individual elements and entire vehicles, while maintaining a high gloss level. The incorporated UV filters ensure color fastness of the base paint.

▶ ADVANTAGES

- easy application
- very good flow
- high clarity
- high gloss
- good drying time
- easy to polish



CZAS SCHNIĘCIA LAKIERU

The lacquer's quick drying allows to significantly reduce the time required to repair individual elements and entire vehicles while also maintaining a high level of gloss.

Klarlack S Pro
Colorless, two-component acrylic lacquer

APP NO.	Packaging	Color	Volume	Col. pack.
020118	can	colorless	1,0 L	6 pcs.
020119	can	colorless	5,0 L	3 pcs.

Harter Klarlack S Pro
Acrylic lacquer curing agent

APP NO.	Packaging	Type	Volume	Col. pack.
020360	can	normal	0,5 L	12 pcs.
020361	can	normal	2,5 L	3 pcs.
020362	can	fast	0,5 L	12 pcs.
020363	can	fast	2,5 L	3 pcs.



2 obj. APP Klarlack S Pro
1 obj. APP Harter Klarlack S Pro
0-5% APP Acryl Verdünnung



18 s
4 mm DIN
+20°C



ø1,2-1,4 mm
2-3 bar
2 x 1



5-10 min
+20°C



3-4 h / +20°C
30 min / +60°C



APP Klarlack S Pro clear lacquer is resistant to weather conditions in different climate zones.

Two hardener types are available Normal and Fast drying one to ensure optimal work effects at the given ambient temperature and area of surface.



• APP Klarlack Spezial S

Colorless, two-component acrylic lacquer with a special effect 2:1

VOC/LZO 2004/42/EC- II B (e)(840): <486 g/l

APP Klarlack Spezial S is a two-component, colorless, HS class acrylic lacquer with a high gloss factor and good scratch resistance. It features very good flow and clarity. The lacquer is resistant to atmospheric effects in various climate zones. Thanks to the incorporated UV filters, it ensures color fastness of the base paint. Intended for repairing elements and entire vehicles as the top coat in two-layer vehicle body refinishing coatings.

▶ ADVANTAGES

- in typical conditions works without the addition of a thinner
- very good flow guarantees fine textures on the surface of the cured lacquer
- easy to polish after curing
- high resistance to scratches
- the choice of two curing agent types: normal and quick allows to adapt the lacquer to the ambient temperature and size of the coated surface

Klarlack Spezial S
Two-component, colorless acrylic lacquer with a special effect

APP NO.	Packaging	Color	Volume	Col. pack.
020109	can	colorless	1,0 L	6 pcs.
020110	can	colorless	5,0 L	3 pcs.

Harter Spezial S
Acrylic lacquer curing agent

APP NO.	Packaging	Type	Volume	Col. pack.
020317	can	normal	0,5 L	12 pcs.
020318	can	normal	2,5 L	3 pcs.
020319	can	fast	0,5 L	12 pcs.
020320	can	fast	2,5 L	3 pcs.



2 obj. APP Klarlack Spezial S
1 obj. APP Harter Klarlack Spezial S
0-5% APP Acryl Verdünnung



18 s
4 mm DIN
+20°C



ø1,2-1,3 mm
2-3 bar
2 x 1



5-10 min
+20°C



5 h / +20°C
30 min / +60°C



• APP Klarlack UHS 420

Colorless, two-component acrylic lacquer 2:1

VOC/LZO: 2004/42/EC - II B (d)(420): 420 g/l

APP Klarlack UHS 420 is a low-emission, quick-drying, two-component, colorless, premium class VOC 420 class lacquer. It is characterized by very good flow. It is easy to apply and polish. The product guarantees high gloss and color fastness of the base paint. Thanks to the incorporation of special resins, the lacquer's structure is more resistant to chipping from stones and minor damage.

➤ ADVANTAGES

- easy application on large surfaces
- high mechanical resistant to chipping and minor damage
- does not require the addition of a thinner
- features an increased solid particle Volume and VOC below 420 g/l
- material savings of 15-20% compared to standard lacquers



Klarlack UHS 420
Colorless, two-component acrylic lacquer

APP NO.	Packaging	Color	Volume	Col. pack.
020137	can	colorless	1,0 L	6 pcs.
020138	can	colorless	5,0 L	3 pcs.

Harter Klarlack UHS 420
Curing agent for acrylic lacquer

APP NO.	Packaging	Type	Volume	Col. pack.
020375	can	normal	0,5 L	6 pcs.
020377	can	normal	2,5 L	3 pcs.
020379	can	fast	0,5 L	6 pcs.
020381	can	fast	2,5 L	3 pcs.

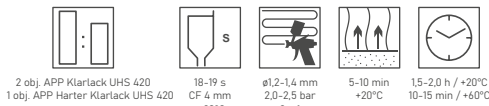

• APP Klarlack Classic

Two-component, colorless acrylic lacquer 2:1

VOC/LZO: 2004/42/EC - II B (e)(840): 450,3 g/l

APP Klarlack Classic is a two-component, colorless, HS class acrylic lacquer with a high gloss factor. It is characterized by good flow and very high clarity. Thanks to the incorporation of UV filters, it ensures color fastness of the conventional and water-dilutable base coat. Intended for repairing elements and entire vehicles as the top coat in two-layer vehicle body refinishing coatings.

➤ ADVANTAGES

- dries well in varied conditions
- allows to easily obtain the desired texture on the surface of cured lacquer
- after sufficient evaporation of the first layer, the ready coat has a lasting, high gloss
- the choice of two curing agent types: normal and quick allows to adapt the lacquer to the ambient temperature and size of the coated surface



Klarlack Classic
Two-component, colorless acrylic lacquer

APP NO.	Packaging	Color	Volume	Col. pack.
020111	can	colorless	1,0 L	6 pcs.
020112	can	colorless	5,0 L	3 pcs.

Harter Klarlack Classic
Acrylic lacquer curing agent

APP NO.	Packaging	Type	Volume	Col. pack.
020321	can	normal	0,5 L	12 pcs.
020322	can	normal	2,5 L	3 pcs.
020323	can	fast	0,5 L	12 pcs.
020324	can	fast	2,5 L	3 pcs.

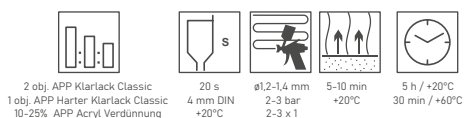

• APP Klarlack Compact

Two-component colorless acrylic lacquer 2:1

VOC/LZO: 2004/42/EC - II B (e)(840): 530 g/l

The APP Klarlack Classic two-component colorless acrylic lacquer 2:1 is an HS class high gloss acrylic lacquer characterized by good flow and very high clarity. Thanks to the incorporated UV filters, it ensures color fastness of the water-dilutable base paint. Intended for repairing elements and entire vehicles as the top coat in two-layer vehicle body refinishing coatings.

APP Klarlack Compact is a high gloss two-component colorless acrylic lacquer. It is characterized by very good flow and clarity. Thanks to the incorporated UV filters, it ensures color fastness of the water-dilutable base paint. Intended for repairing elements and entire vehicles as the top coat in two-layer vehicle body refinishing coatings. For use with water-dilutable and conventional base coat lacquers.

➤ ADVANTAGES

- dries in difficult working conditions (lower temperatures)
- work with the product similar to ms type lacquers
- works without the addition of a thinner
- easy to polish after curing



Klarlack Compact

Two-component colorless acrylic lacquer

APP NO.	Packaging	Color	Volume	Col. pack.
020116	can	colorless	1,0 L	6 pcs.
020117	can	colorless	5,0 L	3 pcs.

Harter Klarlack Compact

Acrylic lacquer curing agent

APP NO.	Packaging	Type	Volume	Col. pack.
020340	can	normal	0,5 L	12 pcs.
020341	can	normal	2,5 L	3 pcs.
020343	can	fast	0,5 L	12 pcs.
020344	can	fast	2,5 L	3 pcs.

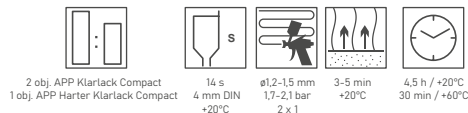

• APP Klarlack Smart

Two-component, quick-drying, colorless acrylic lacquer 4:1

VOC/LZO 2004/42/EC - II B (b)(840): 572.3 g/l

APP Klarlack Smart is a very quickly drying, colorless acrylic lacquer with a high gloss factor. Intended for quick SMART type repairs and lacquering individual elements, as the top coat of multi-layer car body refinishing coatings.

➤ ADVANTAGES

- very short drying time
- works without the addition of a thinner
- easy to polish after curing
- leaves very smooth and easy to polish transitions during spot repairs
- for use with water-dilutable and conventional base paints



Klarlack Smart

Two-component, quick-drying, colorless acrylic lacquer

APP NO.	Packaging	Color	Volume	Col. pack.
020103	can	colorless	1,0 L	12 pcs.

Harter Klarlack Smart

Acrylic lacquer curing agent, quick-drying

APP NO.	Packaging	Volume	Col. pack.
020290	can	0,25 L	12 pcs.

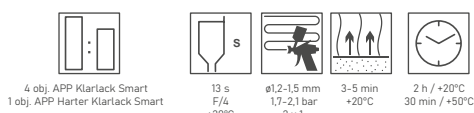

• APP Klarlack Matt

Two-component, quick-drying, colorless acrylic lacquer 4:1

VOC/LZO 2004/42/EC- II B (e)(840): 514,2 g/l

The APP Klarlack Smart two-component, quick-drying, colorless, acrylic matt lacquer 4:1 is a high gloss acrylic lacquer. Intended for quick SMART type repairs and lacquering individual elements, as the top coat of multi-layer car body refinishing coatings.

The APP Klarlack Matt is an exceptionally versatile, matt, colorless lacquer. Intended for repairing individual details and entire elements as a matt finishing layer in multi-layered car body refinishing coatings. For use with water-dilutable and conventional base paints.

➤ ADVANTAGES

- the lacquer is compatible with colorless lacquer curing agents APP Klarlack Classic, APP Klarlack Pro, APP Klarlack Spezial S
- the matt level adjustment takes place through the addition of colorless glossy lacquers APP Klarlack Classic, APP Klarlack S Pro, APP Klarlack Spezial S
- the lacquer does not introduce additional products to the typical set used by an APP customer

Klarlack Matt

Two-component, colorless, matt, acrylic lacquer

APP NO.	Packaging	Type	Volume	Col. pack.
020180	can	matt	1,0 L	6 pcs.

Harter Klarlack Matt

Matt Acrylic lacquer curing agent

APP NO.	Packaging	Type	Volume	Col. pack.
020321	can	normal	0,5 L	12 pcs.
020323	can	fast	0,5 L	12 pcs.

Harter Klarlack S Pro

Acrylic lacquer curing agent

APP NO.	Packaging	Type	Volume	Col. pack.
020360	can	normal	0,5 L	12 pcs.
020362	can	fast	0,5 L	12 pcs.



2 obj. APP Klarlack Matt

1 obj. APP Harter Klarlack Classic / APP Harter Klarlack S Pro
0-5% APP Acryl Verdünnung



18-20 s
4 mm DIN
+20°C



ø12-13 mm
2-3 bar
2 x 1



5 min
+20°C



5 h / +20°C
30 min / +60°C
12-15 min / IR



• APP Klarlack FD Spray

Colorless, two-component, quick drying spray lacquer

VOC/LZO 2004/42/EC- II B (b)(840): <840 g/l

APP Klarlack FD Spray is a two-component, quick drying spray lacquer. It features very good flow and high gloss and clarity after curing. It is easy to polish when cured. The lacquer is characterized by long lasting resistance to weather conditions. It is intended for repair and renovation of lacquered surfaces, such as car body elements, polycarbonate headlights, etc. For use with water-dilutable and conventional base lacquers.

➤ ADVANTAGES

- nozzle with a wide, elliptical stream shape, similar to a small spray-painting gun
- chemically hardened colorless lacquer
- easy to use – product in a two-component pressurized packaging
- enables performance of Spot/SMART repairs without the need to use a compressor or mini spray-gun

APP NO.	Packaging	Color	Volume	Col. pack.
020120	aerosol	colorless	250 ml	6 pcs.



Dobrze wymieszać
wstrząsając 2 min



Dobrze wymieszać
wstrząsając 2 min



1-2x1
20-40 µm



5-10 min
+20°C



60 min (20 µm) / +20°C
120 min (40 µm) / +20°C
15-20 min / +60°C



Przydatność do użycia
Pot life 14h / +20°C



15-20 min / +60°C



• APP Acryl Harter L

Acrylic lacquer curing agent

APP Acryl Harter L is a curing agent with a standard curing time intended for use with the APP Modular acrylic lacquer and similar types of lacquers.

➤ ADVANTAGES

- ensures correct and quick bonding of cured lacquers
- for use in smaller or larger repairs, as well as during repairs of entire vehicles
- the curing agent ensures achievement of a durable and resistant coating

APP NO.	Packaging	Type	Volume	Col. pack.
020355	can	normal	0,5 L	6 pcs.
020356	can	normal	5,0 L	4 pcs.



Zamknięcie
Packaging



Chronicznie
przed wilgocią



• APP Rally Color Spray Acrylic paint

VOC/LZO 2004/42/EC- II E (e)(840): <673,5 g/l

High quality series of fast-drying acrylic topcoats in aerosol. It is characterized by very good adhesion and high resistance to atmospheric conditions.

▶ ADVANTAGES

- universal in applications
- easy to use



APP NO.	Packaging	Color / Type	Volume	Col. pack.
210101	aerosol	white	500 ml	6 pcs.
210102	aerosol	black matt	500 ml	6 pcs.
210103	aerosol	black gloss	500 ml	6 pcs.
210104	aerosol	silver	500 ml	6 pcs.
210105	aerosol	colorless	500 ml	6 pcs.
210111	aerosol	white	600 ml	6 pcs.
210112	aerosol	black matt	600 ml	6 pcs.
210113	aerosol	black gloss	600 ml	6 pcs.
210114	aerosol	silver	600 ml	6 pcs.
210115	aerosol	colorless	600 ml	6 pcs.



• APP Brake Caliper Spray Lacquer for brake calipers

VOC/LZO 2004/42/EC- II E (e)(840): 556,4 g/l

APP Brake Caliper Spray is a one-component, high coverage, thermo-resistant top coat lacquer with a lasting gloss. It is intended for varnishing brake calipers during tuning works. It ensures protection against corrosion and weather effects. It is resistant to UV radiation, petrol and chemicals, as well as temperatures up to 110°C (short-term – up to 150°C)

▶ ADVANTAGES

- attractive colors with high gloss
- high efficiency and good coverage (1 package per 4 calipers)
- resistance to difficult working conditions
- corrosion protection
- easy to use



APP NO.	Packaging	Color / Type	Volume	Col. pack.
210150	aerosol	red	400 ml	6 pcs.
210151	aerosol	yellow	400 ml	6 pcs.
210152	aerosol	blue	400 ml	6 pcs.

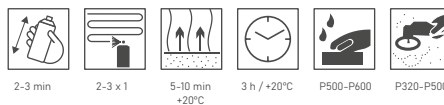

• APP Bumper Paint 2 in 1 One-component structural bumper paint

VOC/LZO 2004/42/EC- II E (e)(840): 490 g/l

APP Bumper Paint 2 in 1 is a one-component, quick-drying structural paint for repairing and renovating plastic elements such as: bumpers, side moldings, exterior mirror frames, etc. It enables recreation of the factory texture, giving the surface an original and fresh appearance.

▶ ADVANTAGES

- does not require the use of plastic primers
- does not require the use of elasticizing agents
- gloss type - satin gloss
- resistant to changing weather conditions



APP NO.	Packaging	Color / Type	Volume	Col. pack.
020801	can	black	1,0 L	6 pcs.
020802	can	grey	1,0 L	6 pcs.



• APP Bumper Paint 2 in 1 Spray

Structural bumper paint

VOC/LZO 2004/42/EC- II E (e)(840): 490 g/l

APP Bumper Paint 2 in 1 Spray is a one-component, quick-drying structural paint in a pressurized package, intended for repairing and renovating plastic elements such as: bumpers, side moldings, exterior mirror frames, etc. It enables recreation of the factory texture, giving the surface an original and fresh appearance.

➤ ADVANTAGES

- does not require the use of plastic primers
- does not require the use of elasticizing agents
- gloss type - satin gloss
- resistant to changing weather conditions
- easy to use

APP NO.	Packaging	Color /Type	Volume	Col. pack.
020811	aerosol	black	400 ml	12 pcs.
020812	aerosol	grey	400 ml	12 pcs.

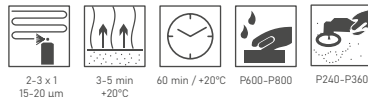

• APP Bumper Paint Color Spray

Plastic paint

VOC/LZO 2004/42/EC- II E (e)(840): 676,9 g/l

APP Bumper Paint Color Spray are one-component, quick-drying paints intended for renovating bumpers, side moldings, exterior mirror frames and other car exterior and interior plastic elements. Paints in this series are characterized by a lack of their own structure, excellent coverage, color fastness, and high matt. The paints are resistant to scratching, weather effects and low concentration chemical agents.

➤ ADVANTAGES

- quick-drying and easy to use.
- do not require the use of plastic primers or elasticizing agents.
- available in six typical colors
- for use on car exteriors and interiors
- allow to obtain the desired color and texture after using a structural paint, e.g. APP Bumper Paint Structure Spray

APP NO.	Packaging	Color /Type	Volume	Col. pack.
210403	aerosol	black	400 ml	6 pcs.
210404	aerosol	grey	400 ml	6 pcs.
210405	aerosol	light grey	400 ml	6 pcs.
210406	aerosol	dark grey	400 ml	6 pcs.
210407	aerosol	anthracite	400 ml	6 pcs.
210408	aerosol	dark anthracite	400 ml	6 pcs.



• APP Bumper Paint Structure Spray

Structural plastic paint

VOC/LZO 2004/42/EC- II E (e)(840): 672,8 g/l

APP Bumper Structure Spray are one-component, quick-drying and elastic structural paints. They allow to recreate the texture of a damaged element. The obtained structure depends on the distance from which spraying is carried out, the number and thickness of applied layers. After drying, they can be covered with lacquers in the APP Bumper Paint Color Spray line or other typical top coat paints.

➤ ADVANTAGES

- allow recreation of various textures
- quick-drying and easy to use
- do not require the use of plastic primers or elasticizing agents
- feature specialized nozzles for creating different textures
- two available colors: transparent for bright colors and black for dark colors
- if the desired color is black, then the APP Bumper Paint Structure Spray does not have to be covered by an additional top coat paint

APP NO.	Packaging	Color /Type	Volume	Col. pack.
210410	aerosol	transparent	400 ml	6 pcs.
210411	aerosol	black	400 ml	6 pcs.



• APP L 800°C Silver Spray

Heatproof paint

APP L 800°C Silver Spray is a special purpose, silicone resin-based paint for use on steel and aluminum elements exposed to high temperatures. It is intended for painting engine blocks, radiator conduits, as well as grills, stoves, flues, etc. It does not crack or peel. After heating at 220°C for 1 h, the coating is resistant to water, petrol and scratches.

VOC/LZO 2004/42/EC- II E (e)(840): 662 g/l



> ADVANTAGES

- thermal resistance after curing: 800°C
- excellent adhesion to the substrate without any base coats
- very good coverage and filling

APP NO.	Packaging	Color / Type	Volume	Col. pack.
210433	aerosol	silver	400 ml	6 pcs.

• APP L 650°C Black Spray

Heatproof paint

APP L 650°C Black Spray is a special purpose, silicone resin-based paint for use on steel and aluminum elements exposed to high temperatures. It is intended for painting engine blocks, radiator conduits, as well as grills, stoves, flues, etc. It does not crack or peel. After heating at 220°C for 1 h, the coating is resistant to water, petrol and scratches.

VOC/LZO 2004/42/EC- II E (e)(840): 605,9 g/l



> ADVANTAGES

- thermal resistance after curing: 650°C
- excellent adhesion to the substrate without any base coats
- very good coverage and filling

APP NO.	Packaging	Color / Type	Volume	Col. pack.
210431	aerosol	black	400 ml	6 pcs.

• APP Chrom Spray

Special effect paint

APP Chrom Spray is a one-component, quick-drying, decorative paint with very good coverage, high gloss, and a shade close to the color on the lid. For use on all typical, smooth surfaces, such as metal, wood, glass, and paintable plastics. It is not suited for covering with a colorless lacquer.

VOC/LZO 2004/42/EC- II E (e)(840): 605,9 g/l



> ADVANTAGES

- universal in decorative applications
- easy to use

APP NO.	Packaging	Color / Type	Volume	Col. pack.
210501	aerosol	silver	400 ml	6 pcs.

• APP Gold Spray

Special effect paint

APP Gold Spray is a one-component, quick-drying, decorative paint with very good coverage, high gloss, and a shade close to the color on the lid. For use on all typical, smooth surfaces, such as metal, wood, glass, and paintable plastics. It is not suited for covering with a colorless lacquer.

➤ ADVANTAGES

- universal in decorative applications
- easy to use

APP NO.	Packaging	Color / Type	Volume	Col. pack.
210502	aerosol	gold	400 ml	6 pcs.

VOC/LZO 2004/42/EC- II E (e)(840): 591,6 g/l



• APP Pre Fill Gas Spray

Pressurized filling package

APP Pre Fill Gas Spray is a pressurized filling package. It contains a propellant and organic thinner. The product is intended for filling with paints containing organic fillers in an amount no greater than 100 ml. Nozzle connector type – female. The wide angle rotating nozzle is adapted to applying a wide stream of paint with the option of setting a vertical or horizontal spray, depending on the painted surface.

➤ ADVANTAGES

- package contains a universal organic thinner
- neutral DME propellant gas
- nozzle with excellent atomization
- easy and efficient use, e.g. during spot repairs

APP NO.	Packaging	Volume	Col. pack.
210185	aerosol	300 ml	12 pcs.
210185A	aerosol	300 ml	12 pcs.

VOC/LZO 2004/42/EC- II E (e)(840): 722,7 g/l



• APP Pre Fill Gas Converter

Pressurized filling package with converter

APP Pre-Fill Gas Converter Spray is a pressurized filling package containing a propellant, organic thinner, and an additive converting acrylic, chemically hardened products (2K) into products hardened by thinner evaporation (1K). It is intended for filling with a two-component paint (2K) without a curing agent, in an amount of up to 100 ml. Nozzle connector type - female. The new nozzle type ensures excellent paint atomization.

➤ ADVANTAGES

- highly specialized product for long-term storage of two-component (2K) chemically hardened products
- universal organic thinner with a converter
- neutral DME propellant gas
- nozzle with excellent atomization
- easy and efficient use, e.g. during spot repairs

APP NO.	Packaging	Volume	Col. pack.
210186	aerosol	300 ml	12 pcs.

VOC/LZO 2004/42/EC- II E (e)(840): 722,7 g/l



SPRAY-PAINTING



Modular color
selection system

21-232 SPRAY-PAINTING

- 21-28 Putties and fillers
- 29-36 Base and primers
- 37-46 Top coats
- 47-56 • Modular color selection system**
- 57-62 Thinners, removers and additives
- 63-67 Repair of plastics
- 69-76 Adhesives and sealants
- 77-84 Car body protection and soundproofing
- 85-96 Abrasives
- 97-106 Masking systems
- 107-118 Polishing
- 119-126 OHS
- 127-132 Fabric filters and spray-painting booth accessories
- 133-154 Workshop auxiliary equipment
- 155-170 Various spray-painting products
- 171-178 Spray guns and extruders
- 179-186 Pneumatic grinders
- 187-192 Electric grinders, heat guns and lamps
- 193-198 Work disks
- 199-204 Dust extraction
- 205-208 Radiators
- 209-218 Pneumatics
- 219-222 Spray gun regenerators and washers
- 223-232 Technical sprays

The MODULAR Color Selection System includes:

- 01 mixing devices (mixers)
- 02 pigments
- 03 MODULAR formula software
- 04 Color Box chromatic color template
- 05 color table and wheel board
- 06 scale
- 07 5-angle spectrophotometer



• Color selection system

The APP color system was developed for body-shops providing professional paint repair services

> The system's benefits are:

- economical exploitation
- Modular formula software available online
- modern and professional construction
- specialized training courses conducted by APP technical consultants
- professional workshop image among customers

If you do not need to buy the entire APP Modular System, you can buy the Modular ColorBOX and on its basis order singular ready colors at quantities starting with 0,3 liters
Center +48 061 437 00 20

Find out more about the APP Modular System

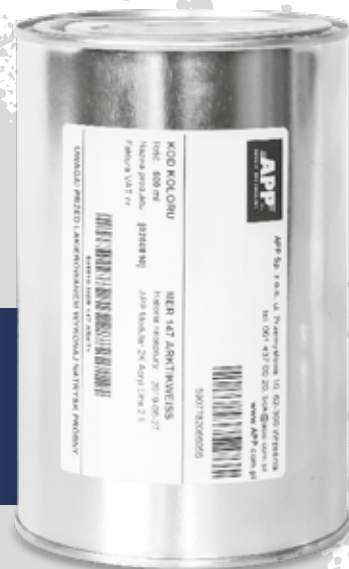

01 mixing device (mixer)



04 Color Box chromatic color template



05 color table and wheel board

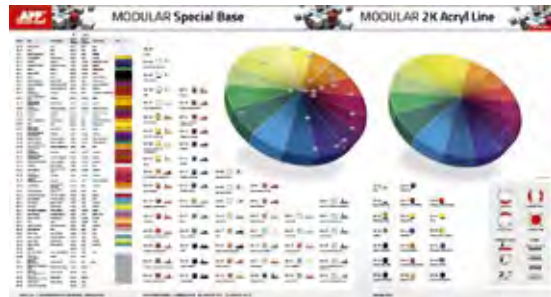

02 pigments



06 scale



03 MODULAR formula software



07 5-angle spectrophotometer



• APP Modular Special Base

Special base paint - pigments SOLID, ALUMINUM, PEARL, XYRALIC and formula resins

The APP Modular Special Base is a base paint with very good utility properties and high coverage. The product is intended for use in multi-layered surface coating systems. It is characterized by excellent adhesion to acrylic, bases, epoxy bases, and old paint coats. After drying, the matt surface ensures excellent adhesion for the colorless lacquer coat.

➤ ADVANTAGES

- mixing proportions with thinner - 1 : 1
- very high efficiency
- very good coverage
- large amount of modifying additives
- easy application



Tonery w mieszalniku
mieszać raz dziennie



100 obj. APP Modular Special Base
100 obj. APP Modular Base Thinner



1,6-1,8 s
4 mm DIN
+20°C



ø1,2-1,4 mm
1,5-2,5 bar
2-3 x 1



P800-P1000



P400-P500



5-7 min



15 min / +20°C

Modular Special Base /

Special paint

- SOLID pigments

VOC/LZO 2004/42/EC- II B (e)(840): <717 g/l

APP NO.	Description	Packaging	Type	Volume	Col. Pack.
0260009	80-00	can	special white	3,5L	2 pcs.
0260010	80-10	can	white	3,5L	2 pcs.
0260011	80-11	can	transparent white	1,0L	3 pcs.
0260012	80-12	can	oxide yellow	1,0L	3 pcs.
0260013	80-13	can	blue	1,0L	3 pcs.
0260015	80-15	can	blue - violet	3,5L	2 pcs.
0260016	80-16	can	green	1,0L	3 pcs.
0260017	80-17	can	deep black	1,0L	3 pcs.
0260021	80-21	can	black	3,5L	2 pcs.
0260022	80-22	can	mixed black	3,5L	2 pcs.
0260029	80-29	can	red-violet	1,0L	3 pcs.
0260031	80-31	can	brown	1,0L	3 pcs.
0260032	80-32	can	transparent red	1,0L	3 pcs.
0260037	80-37	can	transparent oxide yellow	1,0L	3 pcs.
0260038	80-38	can	transparent brown	1,0L	3 pcs.
0260040	80-40	can	violet	1,0L	3 pcs.
0260047	80-47	can	red	1,0L	3 pcs.
0260050	80-50	can	yellow-orange	1,0L	3 pcs.
0260052	80-52	can	yellow	1,0L	3 pcs.
0260053	80-53	can	transparent yellow-green	1,0L	3 pcs.
0260054	80-54	can	transparent red-violet	1,0L	3 pcs.
0260055	80-55	can	blue-green	1,0L	3 pcs.
0260056	80-56	can	green-blue	1,0L	3 pcs.
0260058	80-58	can	transparent yellow-orange	1,0L	3 pcs.
0260060	80-60	can	transparent red	1,0L	3 pcs.
0260061	80-61	can	transparent red-brown	1,0L	3 pcs.
0260065	80-65	can	transparent red	1,0L	3 pcs.
0260066	80-66	can	semi-transparent red	1,0L	3 pcs.
0260068	80-68	can	orange	1,0L	3 pcs.



Modular Special Base /

Special paint

- ALUMINUM pigments

VOC/LZO 2004/42/EC- II B (e)(840): 717 g/l

APP NO.	Description	Packaging	Type	Volume	Col. Pack.
0260090	80-90	can	aluminum medium grain	1,0L	3 pcs.
0260091	80-91	can	aluminum fine grain	3,5L	2 pcs.
0260092	80-92	can	mirror - very coarse grain	1,0L	3 pcs.
0260093	80-93	can	very fine grain	3,5L	2 pcs.
0260094	80-94	can	mirror - medium grain	3,5L	2 pcs.
0260095	80-95	can	fine grain	1,0L	3 pcs.
0260077	80-77	can	gold	1,0L	3 pcs.



Modular Special Base /

Special paint

- PEARL pigment

VOC/LZO 2004/42/EC- II B (e)(840): 717 g/l

APP NO.	Description	Packaging	Type	Volume	Col. Pack.
0260033	80-33	can	pearl bright orange	1,0L	3 pcs.
0260062	80-62	can	pearl fine red	1,0L	3 pcs.
0260063	80-63	can	pearl white	1,0L	3 pcs.
0260064	80-64	can	pearl red	1,0L	3 pcs.
0260069	80-69	can	pearl fine white	1,0L	3 pcs.
0260070	80-70	can	pearl bright red	1,0L	3 pcs.
0260071	80-71	can	pearl blue	1,0L	3 pcs.
0260072	80-72	can	pearl green	1,0L	3 pcs.
0260073	80-73	can	pearl yellow	1,0L	3 pcs.
0260074	80-74	can	pearl green-blue	1,0L	3 pcs.
0260075	80-75	can	pearl violet	1,0L	3 pcs.
0260076	80-76	can	pearl copper	1,0L	3 pcs.
0260080	80-80	can	pearl graphite	1,0L	3 pcs.
0260088	80-88	can	pearl fine white	1,0L	3 pcs.



APP NO.	Description	Packaging	Type	Volume	Col. Pack.
0260079	80-79	can	xyralllic red	1,0L	3 pcs.
0260081	80-81	can	xyralllic white	1,0L	3 pcs.
0260082	80-82	can	xyralllic blue	1,0L	3 pcs.
0260083	80-83	can	xyralllic gold	1,0L	3 pcs.
0260084	80-84	can	xyralllic green	1,0L	3 pcs.



APP NO.	Description	Packaging	Type	Volume	Col. Pack.
0260087	80-87	can	colorless	3,5 L	2 pcs.
0260099	80-99	can	chameleon flop	1,0 L	3 pcs.



• APP Modular Colour Ink Pigmentation additives

VOC/LZO 2004/42/EC- II B (e)(840): 810g/l

APP Modular Colour Ink is a pigmentation additive which is part of base paint formulas in the APP Modular Special Base color system. The additive's application allows to obtain high intensity colors for motorcycles and car bodywork.

➤ ADVANTAGES

- does not require mechanical mixing
- allows to obtain the latest, intense colors
- expands the number of formulas to motorcycles

APP NO.	Description	Packaging	Type / Color	Volume	Col. Pack.
0260041	80-41	bottle	red	500 ml	6 pcs.
0260042	80-42	bottle	orange	500 ml	6 pcs.
0260043	80-43	bottle	blue	500 ml	6 pcs.
0260044	80-44	bottle	yellow	500 ml	6 pcs.
0260045	80-45	can	brown	500 ml	6 pcs.
0260046	80-46	can	black	500 ml	6 pcs.



• APP Modular Magic Mist Pigmentation additives

APP Modular Magic Mist is a pigmentation additive which is part of base paint formulas in the APP Modular Special Base color system. The additive allows to create colors with special effects. Depending on the angle at which the surface is observed, different color effects can be obtained.

➤ ADVANTAGES

- does not require mechanical mixing
- essential to obtaining chameleon type effects

APP NO.	Description	Packaging	Type / Color	Volume	Col. Pack.
0260024	80-24	bottle	yellow-blue	100 ml	4 pcs.
0260025	80-25	bottle	violet-green	100 ml	4 pcs.
0260026	80-26	bottle	green-red	100 ml	4 pcs.
0260027	80-27	bottle	green-orange	100 ml	4 pcs.



• APP Modular Special Base Liquid Aluminium Pigmentation additive

VOC/LZO 2004/42/EC- II B (e)(840): 840 g/l

APP Modular Special Base 80-96 Liquid Aluminum is a pigmentation additive with the effect of a very fine, silver grain, constituting a part of base formulas in the APP Modular Special Base color system (e.g. in the Mazda 46G color). This additive finds application in silver, grey, graphite and other formulas, but can also be mixed with other pigments in the APP Modular Special Base system, and additives such as: Magic Mist, Color Ink, Interior Converter 80-04, blending resin 80-01. It can also be used when painting car wheel rims, railings, finishing strips, etc. APP Modular Special Base 80-96 Liquid Aluminum is a ready to use product.

APP NO.	Description	Packaging	Type / Color	Volume	Col. Pack.
0260096	80-96	can	liquid aluminum	1,0 L	3 pcs.



• APP Modular Special Base Super Black Basecoat Super black base paint coat

VOC/LZO 2004/42/EC- II B (e)(840): 840 g/l

APP Modular Special Base 80-02 Super Black is characterized by intensely deep blackness (the color's spectrum is shifted towards navy blue, which is why the human eye perceives it as the blackest color). The 80-02 base paint is not part of color formulas in the APP Modular color system, but can be mixed with other pigments in the APP Modular Special Base system with the additives: Magic Mist, Color Ink, Interior Converter 80-04, and blending resin 80-01.

APP NO.	Description	Packaging	Type / Color	Volume	Col. Pack.
0260002	80-02	can	super black	1,0 L	3 pcs.
0260003	80-02	can	super black	3,5 L	2 pcs.



• APP Modular Special Base Thinner Base thinner

APP Modular Special Base Thinner is a thinner for adjusting the spraying viscosity of organic base paints. It is intended for use with the APP Modular Special Base paint and other paints of a similar type. The thinner supports the painter's work with the newest color formulas of base paints, as well as metallic and pearl paints.

➤ ADVANTAGES

- product specialized for work with base paints
- formula optimized for many refinishing systems
- two evaporation rates (80-140 – slow and 80-130 – normal)
- supports the painter in working with metallic paints

APP NO.	Description	Packaging	Type	Volume	Col. Pack.
0260131	80-130	can	normal	1,0L	6 pcs.
0260141	80-140	can	slow	1,0L	6 pcs.
0260135	80-130	can	normal	5,0L	4 pcs.
0260145	80-140	can	slow	5,0L	4 pcs.



• APP Modular Special Base Blending Resin Resin for blending with base paints

VOC/LZO 2004/42/EC- II B (e)(840): 726 g/l

The APP Modular Special Base 80-01 blending resin is intended for evening out color differences during SPOT/SMART repairs and blending adjacent elements with paints in the APP Modular system.

➤ ADVANTAGES

- high efficiency: 1,0 L provides 2,0 L of a ready to use product.
- does not alter the color of the substrate and applied base
- dual purpose: as an additional layer or additive to applied base coats

APP NO.	Description	Packaging	Type	Volume	Col. Pack.
0260001	80-01	can	for blending	1,0 L	3 pcs.



• APP Modular Special Base Interior Converter Base paint converter

VOC/LZO 2004/42/EC- II B (e)(840): 707 g/l

APP Modular Special Base 80-04 Interior Converter is an additive intended for use with APP Modular Special Base paints. After spraying the base paint and converting additive mix onto interiors of, e.g. the motor compartment, trunk compartment, recess, etc., there is no need to use a colorless lacquer. After using the additive, the surface receives a satin finish and becomes resistant to mechanical damage caused by exploitation.

➤ ADVANTAGES

- reduces interior lacquering costs
- adapts the interior restoration to factory technology
- reduces time and simplifies interior lacquering technology

APP NO.	Description	Packaging	Type / Color	Volume	Col. Pack.
0260004	80-04	can	converter	1,0 L	3 pcs.



• APP Modular 2K Acryl Line Acrylic paint

VOC/LZO 2004/42/EC- II B (e)(840): 840 g/l

APP Modular 2K Acryl Line 2:1 is a low-emission, two-component acrylic-polyurethane paint with a short drying time. It is intended for painting utility vehicles, busses, and structural elements.

➤ ADVANTAGES

- high efficiency
- high and stable gloss
- very good flow properties
- high resistance to mechanical damage

APP NO.	Description	Packaging	Color / Type	Volume	Col. Pack.
0250000	50-00	can	white	3,5L	2 pcs.
0250010	50-10	can	mixed white	3,5L	2 pcs.
0250021	50-21	can	specjal black	3,5L	2 pcs.
0250012	50-12	can	oxide yellow	3,5L	2 pcs.
0250016	50-16	can	green	3,5L	2 pcs.
0250019	50-19	can	intermediate black	3,5L	2 pcs.
0250022	50-22	can	mixed black	3,5L	2 pcs.
0250029	50-29	can	violet	3,5L	2 pcs.
0250031	50-31	can	oxide red	3,5L	2 pcs.
0250035	50-35	can	bright yellow	1,0L	3 pcs.
0250044	50-44	can	blue	3,5L	2 pcs.
0250046	50-46	can	orange	1,0L	3 pcs.
0250047	50-47	can	brilliant red	3,5L	2 pcs.
0250050	50-50	can	deep yellow	1,0L	3 pcs.
0250051	50-51	can	transparent orange	1,0L	3 pcs.
0250052	50-52	can	yellow	1,0L	3 pcs.
0250053	50-53	can	transparent yellow-green	1,0L	3 pcs.
0250054	50-54	can	violet-red	3,5L	2 pcs.
0250056	50-56	can	dark green	3,5L	2 pcs.
0250060	50-60	can	intense black	3,5L	2 pcs.
0250099	50-99	can	slow curing resin	3,5L	2 pcs.



Tonery w mieszalniku
mieszac raz dziennie



100 obj. APP Modular 2K Acryl Line
APP Härter Klarlack Classic
APP Härter Klarlack S Pro
10-20% APP Acryl Verdunnung



21-24 s
4 mm DIN
+20°C



ø1,3-1,6 mm
2,0-3,5 bar
2 x 1



5-10 min



P600-P800



P320-P400



12 h / +20°C
45 min / +60°C

• APP Modular 2K Acryl Line 50-96 Matting additive

VOC/LZO 2004/42/EC- II B (e)(840): 840 g/l

The matting additive APP Modular 2K Acryl Line 50-96 is intended for reducing the surface gloss of the APP Modular 2K Acryl Line acrylic lacquer and other two-component acrylic top coats of similar types. The additive does not cause changes to the color, flow properties and resistance to UV radiation.

➤ ADVANTAGES

- simple and universal application
- allows to obtain any degree of matt
- only slightly increases the lacquer drying time

APP NO.	Description	Packaging	Type / Color	Volume	Col. Pack.
0250096	50-96	can	transparent grey	1,0 L	3 pcs.



• APP Modular 2K Acryl Line

Curing agents

Isocyanate curing agents for two-component APP acrylic lacquers ensure correct and quick bonding of the cured top coat lacquers. Thanks to the ability to choose between two curing agent types: quick and normal, it is possible to adapt the cured product to different working conditions. For lacquers in the Modular 2K Acryl line, we recommend using the following curing agents:



➤ Recommended use of the following curing agents:

- APP Harter Klarlack Classic
- APP Harter Klarlack Spezial S
- APP Harter Klarlack S Pro
- APP Acryl Harter L



APP Modular 2K Acryl Line / Acrylic lacquer curing agent

APP NO.	Packaging	Type	Volume	Col. Pack.
020321	can	normal	0,5 L	12 pcs.
020322	can	normal	2,5 L	3 pcs.
020323	can	fast	0,5 L	12 pcs.
020324	can	fast	2,5 L	3 pcs.

APP Acryl Harter L / Acrylic lacquer curing agent

APP NO.	Packaging	Color	Volume	Col. Pack.
020355	can	normal	0,5 L	6 pcs.
020356	can	normal	5,0 L	4 pcs.

• APP Acryl Verdünnung

Thinner for acrylic product and base coats

APP Acryl Verdünnung is a universal thinner for acrylic products and base coats. It is intended for adjusting the spray viscosity of bases and top coat lacquers during passenger and commercial vehicle refinishing. Thanks to the ability to choose between three thinner types: slow, normal and quick, it is possible to optimize the evaporation time to various working conditions.



➤ ADVANTAGES

- universal application
- formula optimized for many refinishing systems
- three evaporation rates

APP NO.	Packaging	Type	Volume	Col. Pack.
030095	can	normal	0,5L	12 pcs.
030100	can	normal	1,0L	6 pcs.
030101	can	slow	1,0L	6 pcs.
030130	can	normal	5,0L	4 pcs.
030120	can	fast	5,0L	4 pcs.
030131	can	slow	5,0L	4 pcs.



• APP Modular Spectro 5K

5-angle spectrophotometer

A high class, professional color measuring tool. Thanks to precise measurements and connection to the APP Modular formula software's database, it allows to quickly search for the closes color, make adjustments to the formula of the chosen color.

➤ Product properties

- shortens the time needed to search for the correct formula
- device compatible with the APP Modular 3 formula software
- Wi-fi, usb, colored touchscreen
- measurement at 5 angles (15 /25 /45 /75 /110)
- calibration every 14 days (calibration plate)
- easy, quick and precise measurement
- device memory of up to 500 measurements



• APP ColorBOX

Modular color template

The APP Colorbox in a chromatic configuration provides over 6700 color representations, enabling the user to search paint colors without the need to enter the color code and vehicle brand. Easy and clear markings facilitate searching for the appropriate flashcard and, in case of searching for a color without information on the color code or name, the system and markings allow to quickly find the formula in the formula software.



• APP RAL Fan Deck

RAL color templates

The APP RAL color template is a set of 198 standardized colors with gloss intended for comparative specification of colors for industrial and commercial applications. The RAL color system is the primary color designation system for paints and lacquers, plastic materials, etc., independent of their manufacturers. Currently, it is commonly used in the spray-painting, construction, furniture, machine and other industries.



APP NO.	Sales unit
0260005	pcs.

• NTools Modular Mixing Machine

Mixing device with agitators

NTools Modular Mixing Machine to nowoczesna i solidna konstrukcja charakteryzująca się bezobsługową pracą. Urządzenie gwarantuje prawidłowe i precyzyjne wymieszanie pigmentów systemu Colorystycznego APP Modular a także podkładów dostępnych w ofercie APP. Urządzenie obsługuje produkty w standardowych, metalowych canch o pojemnościach 1,0L, 3,5L oraz 4,0L. W komplecie z urządzeniem znajdują się mieszadła w ilości dostosowanej do konfiguracji jaką dany mieszalnik obsługuje.

➤ ADVANTAGES:

- quiet operation
- belt-less, geared drive system
- independent, electric drive for every shelf
- low power consumption - 50 W/shelf
- emergency off switch increasing safety
- switch with a time adjustment in a 1 to 15 minute range
- stable structure
- easy assembly

APP NO.	Description	Type	Sales unit
170352A	6x1,0L 15x3,5L/4,0L	acryl	pcs.
170352B	48x1,0L 9x3,5L/4,0L	base	pcs.
170353	54x1,0L 24x3,5L/4,0L	base + acryl	pcs.



• APP Sortorius PMA Evolution

A modern, highly precise device which allows to exactly measure the required amount of components with an option of readings accurate to two decimal points.

The device's additional advantages are its compatibility with the formula software, a clear display and stability of operation.

Thanks to the formula software's compatibility with the scale it is possible to precisely dose the amount of pigments, observing readings on the computer screen and quickly calculate the formula in case of adding an excessive amount off one of the pigments. This function also works remotely without connecting the scale.

APP NO.	Description	Sales unit
0260107	scale	pcs.



• NTools Modular Mixing Lid

Paint mixer for cans

The Mixers are fitted to pigments and primers available in the in the APP offer in 1,0L, 3,5L and 4,0L packages. They enable thorough mixing and precise dosage of the package Volumes. Resistant to thinners used in the spray-painting industry. The NTools Mixing Lids feature "butterfly" type drives. They are intended for work with NTools Modular Mixing Machine and NTools Paint Mixing Machine mixers or other similar devices.

➤ ADVANTAGES:

- thorough mixing
- precise dosage
- ergonomic grip

APP NO.	Description	Weight / Volume	Sales unit
170356	butterfly	1,0L	pcs.
170357	butterfly	3,5L i 4,0L	pcs.



170356



170357



• NTools Modular Mixing Stand

1,0 L can stand

The 1 liter can stand is intended for use in NTools Modular Mixing Machine and NTools Paint Mixing Machine devices. It enables setting products in packages with a Volume of 1 liter in places intended for 3,5L and 4,0L cans. It is made from stainless steel.

APP NO.	Sales unit
170359	pcs.

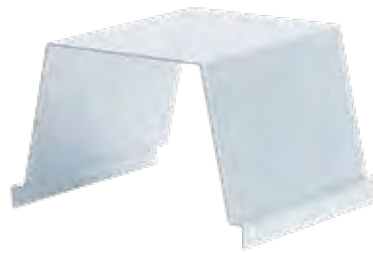

• FORMULA SOFTWARE

The formula software is an essential part of the APP Modular mixing system. Thanks to a large number of available formulas (over 110 k), we are able to obtain any chosen color. Quick and intuitive formula searching, e.g. by color code, color name or manufacturer.

➤ Software functions:

- ability to obtain over 110000 formulas
- ability to easily calculate the cost of the obtained mix, set a custom price list, perform stock management, recalculate the formulas at the moment of adding excessive amounts of one of the pigments
- thanks to the software's compatibility with the scale, we can precisely dose the pigment amounts, observing readings on the computer screen or scale display
- the search engine shows approximate formula colors
- it enables preparation of a ready to use mixture or mixture with a matting additive
- ability to save and edit custom formulas (creating your own color library)
- for difficult, three-layered colors, or ones with low hiding power, the software suggests the use of background colors
- the software has the ability to provide suggested amounts necessary to cover an element
- thanks to the formula software's compatibility with the scale, it is possible to provide precise dosage of the amount of pigments, observing the readings on the computer screen or scale display

Minimum system configuration:
System: Windows XP SP2 (.NET Framework 3.5)



SPRAY-PAINTING

1



Thinners, removers
and additives

21-232 SPRAY-PAINTING

- 21-28 Putties and fillers
- 29-36 Base and primers
- 37-46 Top coats
- 47-56 Modular color selection system
- 57-62 • Thinners, removers and additives**
- 63-67 Repair of plastics
- 69-76 Adhesives and sealants
- 77-84 Car body protection and soundproofing
- 85-96 Abrasives
- 97-106 Masking systems
- 107-118 Polishing
- 119-126 OHS
- 127-132 Fabric filters and spray-painting booth accessories
- 133-154 Workshop auxiliary equipment
- 155-170 Various spray-painting products
- 171-178 Spray guns and extruders
- 179-186 Pneumatic grinders
- 187-192 Electric grinders, heat guns and lamps
- 193-198 Work disks
- 199-204 Dust extraction
- 205-208 Radiators
- 209-218 Pneumatics
- 219-222 Spray gun regenerators and washers
- 223-232 Technical sprays

• APP Modular Special Base Thinner

Base thinner

The APP Modular Special Base Thinner is a thinner for adjusting the spray viscosity of organic base coats. It is intended for use with the APP Modular Special Base coat and other similar types of coats. The thinner facilitates the painter's work with the newest color formulas of base coats as well as metallic and pearl coat.

▶ ADVANTAGES

- product specialized for work with base coats
- formula optimized for many refinishing systems
- two vaporization rates (80-140 – slow and 80-130 – normal)
- facilitates the painter's work with metallic coats

APP NO.	Description	Packaging	Type	Volume	Col. Pack.
0260131	80-130	can	normal	1,0L	6 pcs.
0260141	80-140	can	slow	1,0L	6 pcs.
0260135	80-130	can	normal	5,0L	4 pcs.
0260145	80-140	can	slow	5,0L	4 pcs.



• APP Acryl Verdünnung

A thinner for acrylic products and base coats

The APP Acryl Verdünnung is a universal thinner for acrylic products and base coats. It is intended for regulating the spray viscosity of base and top coats during refinishing of passenger and commercial vehicles. Thanks to the ability to choose between three thinner types: slow, normal and quick, it is possible to optimize the evaporation time in different working conditions.

▶ ADVANTAGES

- universal application
- formula optimized for many refinishing systems
- three vaporization rates

APP NO.	Packaging	Type	Volume	Col. Pack.
030095	can	normal	0,5L	12 pcs.
030100	can	normal	1,0L	6 pcs.
030101	can	slow	1,0L	6 pcs.
030130	can	normal	5,0L	4 pcs.
030120	can	fast	5,0L	4 pcs.
030131	can	slow	5,0L	4 pcs.



• APP Epoksy Verdünnung

Epoxy product thinner

The APP Epoksy Verdünnung is a thinner for epoxy products. It is intended for regulating the spray viscosity of primers and base coats during refinishing of passenger and commercial cars. For use with APP Grund EP and other epoxy products used for vehicle body repair.

▶ ADVANTAGES

- specialized product
- formula optimized for many refinishing systems

APP NO.	Packaging	Volume	Col. Pack.
030146	can	1,0L	6 pcs.



• APP W 900

Regular preparation for removing silicone

The APP W 900 is a cleaning and degreasing preparation with a standard evaporation time. It ensures optimal grip of applied products and prevents the formation of silicone craters during painting. For use on uninsulated metal surfaces, old paint coats, base paints, putties, and filling coats prior to applying the finish.

▶ ADVANTAGES

- does not leave smudges
- removes contaminants and residue, such as: silicone, PTFE, oil and grease
- if necessary, can be used to degrease polyester putty surfaces

APP NO.	Packaging	Type	Volume	Col. Pack.
030150	can	normal	1,0L	6 pcs.
030160	can	normal	5,0L	4 pcs.



Zamykać Packaging



• APP W 911

Silicone removal cleaner - slow

APP W 911 is a cleaning agent with a modified formula and extended evaporation time. It ensures maximum adhesion to the applied products and prevents the formation of silicone craters during spray-painting. It is intended for cleaning and degreasing uninsulated metal surfaces, old paint coats and base paints at all stages of spray-painting works.

➤ ADVANTAGES

- long evaporation time
- does not leave smudges
- long effect on contaminants
- enables thorough removal of the applied cleaner with dissolved contaminants

APP NO.	Packaging	Type	Volume	CoL. Pack.
030151	can	slow	1,0L	6 pcs.
030161	can	slow	5,0L	4 pcs.



Zamykač
Packaging



• APP WK 900

Cleaner for plastics

APP WK 900 is an antistatic cleaning and degreasing agent. It is intended for removal of contaminants such as: silicone, PTFE, oils and grease from plastic surfaces intended for spray-painting. It prevents the accumulation of electrostatic charges on plastic materials during cleaning, ensures optimal adhesion of applied products and prevents the formation of silicone craters during spray-painting.

➤ ADVANTAGES

- does not leave smudges
- prevents static buildup on plastic materials

APP NO.	Packaging	Volume	CoL. Pack.
030170	bottle	1,0L	6 pcs.



• APP WB 910

Water-based cleaner for conventional and water-soluble systems

APP WB 910 is a water-based cleaner with a very low volume of organic solvents (VOC < 20%). Thanks to the isopropyl alcohol Volume, the cleaner perfectly removes contaminants, preventing the formation of silicone craters. It removes grease and salt, ensures optimal adhesion of applied surface products. It eliminates the formation of paintwork damage caused by salt residues.

➤ ADVANTAGES

- does not leave smudges
- removes salt
- is more efficient than organic cleaners
- is safe for the environment

APP NO.	Packaging	Volume
030189	bottle	1,0L
030190	kanister	5,0L



• APP BENZ Cleaner

The APP BENZ cleaner is a mixture of petroleum-derived solvents, acetone, toluene and other additives intended for cleaning and degreasing surfaces prior to application of putty, bases and paints. For use on uninsulated metal surfaces, old paint coats and base paints and filling coats.

➤ ADVANTAGES

- good cleaning and degreasing properties
- minor addition of acetone to facilitate washing off

APP NO.	Packaging	Volume
030650	can	5,0L



• APP RC 01 Nitro thinner

The APP RC 01 Nitro thinner is a thinner for regulating the spray viscosity of nitrocellulose products and for washing tools and spray guns.

> ADVANTAGES

- very good washing properties
- typical, non-choking odor
- colorless, with perfect clarity

APP NO.	Packaging	Volume
030300	can	5,0 L



• APP RC 02 Nitro solvent

The APP RC 02 Nitro solvent is a thinner for nitrocellulose products and for washing tools. It has the form of a colorless, uniform, clear liquid. It is a mixture of toluene, acetone and methyl acetate, with a characteristic, non-choking odor.

> APPLICATION

- for washing tools, pumps, hoses and spray guns
- for use in automated spray gun washers
- for adjusting the working viscosity of nitrocellulose or similar paints and lacquers

APP NO.	Packaging	Volume
030305	canister	5,0 L



• APP Paint Ex Plus Spray Preparation for removing old paint and paint coats

The APP Paint Ex is a chemical compound for removing paints and lacquers. It is used to remove: primers, bases, top coats and lacquers, enamel and polyurethanes from metal, glass, ceramic tiles, concrete, bricks and wood. A non-corrosive compound for rinsing with a solvent or water. The product is intended only for professional use in vehicle repair and industry. Does not contain methylene chloride (dichloromethane) suspected of causing cancer!

> ADVANTAGES

- easy to use
- fast and effective
- saves time and money

APP NO.	Packaging	Volume	Sales unit
211001	aerosol	400 ml	6 pcs.



• APP Gun Cleaner Spray Preparation for spray gun cleaning after using conventional paints

The APP Gun Cleaner Spray is a solvent-based cleaning preparation containing organic solvents, acetone, and preserving additives. It is intended for cleaning spray guns used in conventional systems.

> ADVANTAGES

- easy to use
- fast and effective
- cleans hard to reach areas under pressure

APP NO.	Packaging	Volume	Sales unit
210901	aerosol	400 ml	6 pcs.



• APP Loser

Blending solvent

A solvent for dissolving the ends of painted surfaces and joining them in a seamless way with old acrylic paint. The additive is intended for joining acrylic paint with an older layer on one plane during SPOT/SMART type repairs.

➤ ADVANTAGES

- does not alter the color of the applied paint or substrate
- does not alter the translucency of colorless paint
- easy to use
- dual purpose application: as an additive to paint or as additional spray

APP NO.	Packaging	Volume	Sales unit
030350	can	1,0 L	6 pcs.



• APP Loser Spray

Blending solvent

A solvent for dissolving the ends of painted surfaces and joining them in a seamless way with old acrylic paint. The additive is intended for joining acrylic paint with an older layer on one plane during SPOT/SMART type repairs.

➤ ADVANTAGES

- does not alter the color of the substrate
- does not alter the translucency of colorless paint
- easy to use

APP NO.	Packaging	Volume	Sales unit
030356	aerosol	400 ml	12 pcs.



• APP Anti Silikon

Anti-silicone additive for bases and top coat paint

APP Anti Silikon is an additive for top coat paint that neutralizes the effects of silicone contamination on painted surfaces. It is intended for use in case of signs of contamination during spray-painting, in order to continue work. Silicone contamination surface during painting in the form of spots or small craters, preventing further painting

➤ ADVANTAGES

- does not alter the paint color
- does not extend the drying time
- easy to use

APP NO.	Packaging	Volume	Sales unit
030400	can	0,25L	12. pcs.
030410	can	1,0L	6. pcs.



• APP Elastic

Elasticizing additive for base and top paint coats

APP Elastic is an additive to two-component, chemically hardened products, such as: filler bases as well as colored and colorless top coat paints. It elasticizes the applied coat, which is necessary when painting plastic elements. The elasticized coating is able to withstand vibrations and can sustain deformation of the plastic element. The product is intended for elasticizing coats applied to: PP/EPDM, ABS, PUR Hard and Soft, PC PVC, UP-GFK SMC, PA PBTP.

➤ ADVANTAGES

- minor change in the mixing proportions of the elasticized product
- does not alter the color of the applied paint or laquer

APP NO.	Packaging	Volume	Sales unit
030500	can	1,0L	6 pcs.



SPRAY-PAINTING

1



Repair of plastics

21-232 SPRAY-PAINTING

- 21-28 Putties and fillers
- 29-36 Base and primers
- 37-46 Top coats
- 47-56 Modular color selection system
- 57-62 Thinners, removers and additives
- 63-67 • Repair of plastics**
- 69-76 Adhesives and sealants
- 77-84 Car body protection and soundproofing
- 85-96 Abrasives
- 97-106 Masking systems
- 107-118 Polishing
- 119-126 OHS
- 127-132 Fabric filters and spray-painting booth accessories
- 133-154 Workshop auxiliary equipment
- 155-170 Various spray-painting products
- 171-178 Spray guns and extruders
- 179-186 Pneumatic grinders
- 187-192 Electric grinders, heat guns and lamps
- 193-198 Work disks
- 199-204 Dust extraction
- 205-208 Radiators
- 209-218 Pneumatics
- 219-222 Spray gun regenerators and washers
- 223-232 Technical sprays

• APP WK 900

Cleaner for plastic materials

APP WK 900 is an antistatic cleaning and degreasing compound. It is intended for removing contamination such as: silicone, PTFE, oils and greases from plastic surfaces intended for painting. It prevents electrostatic charge buildup on plastic materials while cleaning, ensures optimal adhesion of applied products, and prevents the formation of silicone craters during spray-painting.

➤ ADVANTAGES

- does not leave smudges
- prevents static buildup on plastic materials

APP NO.	Packaging	Volume	Col. Pack.
030170	bottle	1,0L	6 pcs.



• APP PRG50

Polyurethane adhesive for plastics

APP PRG 50 is a two-component polyurethane, black-colored adhesive, essential in gluing repairs of a broad range of materials from plastic, steel, aluminum, wood and glass. It has a short curing time and high stress resistance. The adhesive undergoes polymerization in ambient temperature and is completely odorless. After curing, it can be mechanically processed and .

➤ APPLICATION

- joining of plastic elements
- gluing boat and yacht elements
- gluing sports equipment
- repair of vehicle details, spoilers, fairing elements
- gluing of electronic equipment

APP NO.	Packaging	Color	Volume	Col. Pack.
220333	cartridge 2 x 25 ml	black	50 ml	12 pcs.



• APP Plastiflex

Putty for use on plastic materials

APP Plastiflex is a polyester filler putty with increased elasticity intended for filling dents and leveling out unevenness during repair of plastic elements. It is characterized by very high elasticity and excellent adhesion to most plastics. Thanks to its creamy consistency, it is easy to model on surfaces with complicated shapes.

➤ ADVANTAGES

- very high elasticity
- very good adhesion
- easy to apply and process
- does not leave holes
- black color – similar to the color of plastic materials

VOC/LZO 2004/42/EC- II B (b)(250): 41 g/l



APP NO.	Packaging	Volume	Sales unit
010448	can	0,5 kg	18 pcs.
010449	can	1,8 kg	8 pcs.





• APP Kunststoff Primer

Grunt na tworzywa sztuczne

APP Kunststoff Primer, APP Kunststoff Primer Spray and APP Kunststoff Primer Transparent are elastic, quick-drying, single-component primers that increase the adhesion of base and top coat paints to plastic surfaces. They are intended for use on plastic elements such as: ABS, EP laminate, PA, PBTP, PC, POM, PP/EPDM, PPO, hard PUR, soft PUR and PVC.

➤ ADVANTAGES

- work in a wet on wet system
- universal application for many substrates
- product ready to spray

APP NO.	Packaging	Color	Volume	Col. Pack.
020901	can	transparent / silver	1 L	6 pcs.
020902	can	transparent	1 L	6 pcs.
020905	aerosol	transparent / silver	400 ml	12 pcs.

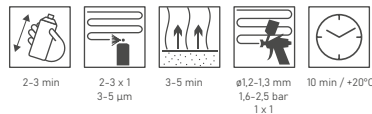

• APP Kunststoff Ref Primer Spray

Primer for plastic materials

VOC/LZO 2004/42/EC- II B (c)(780): 713,7 g/l

APP Kunststoff Ref Primer Spray is an elastic, quick-drying, single-component primer that increases the adhesion of base and top coat paints to plastic substrates. It is intended for use on polycarbonate (PC) globes of headlights and on plastic materials such as: ABS, EP laminate, PA, PBTP, PC, POM, PP/EPDM, PPO, had PUR, soft PUR and PVC.



➤ ADVANTAGES

- completely colorless and transparent
- creates a uniform adhesion surface on PC globes – does not crack on polycarbonate
- for work in a wet on wet system
- universal application for many substrates
- product ready to spray

APP NO.	Packaging	Color	Volume	Col. Pack.
020906	aerosol	transparent	400 ml	12 pcs.

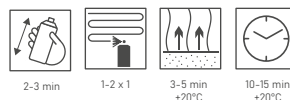

• APP Elastic

Elasticizing additive for base and top coat paints

APP Elastic is an additive for two-component chemically hardened products such as: filling and colored bases, and colorless top coat paints. It elasticizes the applied coating, essential when spray-painting elements made from plastic materials. The elasticized coat is able to withstand vibrations without damage and can sustain deformation of the plastic element. It is intended to elasticize coats applied to: PP/EPDM, ABS, PUR Hard and Soft, PC PVC, UP-GFK SMC, PA PBTP.



➤ ADVANTAGES

- minor change in the mixing proportions of the elasticized product
- does not alter the color of the applied paint

APP NO.	Packaging	Volume	Col. Pack.
030500	can	1,0 L	6 pcs.



• APP Bumper Paint 2 in 1

Single-component structural paint for bumpers

APP Bumper Paint 2 in 1 is a quick-drying, single-component structural paint for repairing and renovating plastic elements such as: bumpers, side moldings, exterior mirror frames, etc. It enables recreation of the factory texture, giving the surface an original, fresh appearance.

▶ ADVANTAGES

- does not require the use of plastic material primers
- does not require elasticizing agents
- gloss type – satin gloss
- resistant to changing weather conditions

APP NO.	Packaging	Color / Option	Volume	Sales unit
020801	can	black	1,0 L	6 pcs.
020802	can	grey	1,0 L	6 pcs.



• APP Bumper Paint 2 in 1 Spray

Structural paint for bumpers

APP Bumper Paint 2 in 1 Spray quick-drying, single-component structural paint in a pressurized can, intended for repair and renovation of plastic elements such as: bumpers, side moldings, exterior mirror frames, etc. It enables recreation of the factory texture, giving the surface an original, fresh appearance.

▶ ADVANTAGES

- does not require the use of plastic material primers
- does not require elasticizing agents
- gloss type – satin gloss
- resistant to changing weather conditions
- easy to use

APP NO.	Packaging	Color / Option	Volume	Sales unit
020811	aerosol	black	400 ml	12 pcs.
020812	aerosol	grey	400 ml	12 pcs.

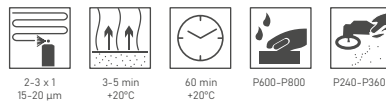

• APP Bumper Paint Color Spray

Paint for plastic materials

APP Bumper Paint Color Spray is a quick-drying, single-component paint intended for renovation of plastic elements such as bumpers, side moldings, exterior mirror frames, as well as vehicle interior elements. The paints in this line are characterized by a lack of their own structure, excellent coverage, lasting color, and high degree of matt. They are resistant to scratching, atmospheric effects, and low concentration chemicals.

▶ ADVANTAGES

- quick-drying and easy to use.
- do not require the use of plastic material primers or elasticizing agents.
- available in six typical colors
- for use on vehicle exteriors and interiors
- allow to give the surface the desired color and texture after application of a structural paint, e.g. APP Bumper Paint Structure Spray

APP NO.	Packaging	Color / Type	Volume	CoL. Pack.
210403	aerosol	black	400 ml	6 pcs.
210404	aerosol	grey	400 ml	6 pcs.
210405	aerosol	light grey	400 ml	6 pcs.
210406	aerosol	dark grey	400 ml	6 pcs.
210407	aerosol	anthracite	400 ml	6 pcs.
210408	aerosol	dark anthracite	400 ml	6 pcs.





• APP Bumper Paint Structure Spray

Structural paint for plastic materials

APP Bumper Structure Spray are quick-drying, single-component and elastic structural paints. They enable recreation of the damaged element's texture. The obtained texture depends on the distance from which the paint is sprayed, as well as the number and thickness of applied layers. After drying, they can be covered with APP Bumper Paint Color Spray or typical top coat lacquers.

► ADVANTAGES

- enable recreation of various textures
- quick-drying and easy to use
- do not require use of plastic material primers or elasticizing agents
- feature a specialized nozzle for creating various textures
- available in 2 colors: transparent for bright colors and black for dark ones
- if the desired target color is black, then the APP Bumper Paint Structure Spray does not have to be covered with an additional top coat paint



APP NO.	Packaging	Color / Type	Volume	Co. Pack.
210410	aerosol	transparent	400 ml	6 pcs.
210411	aerosol	black	400 ml	6 pcs.

SPRAY-PAINTING

1



Adhesives
and sealants

21-232 SPRAY-PAINTING

- 21-28 Putties and fillers
- 29-36 Base and primers
- 37-46 Top coats
- 47-56 Modular color selection system
- 57-62 Thinners, removers and additives
- 63-67 Repair of plastics
- 69-76 • Adhesives and sealants**
- 77-84 Car body protection and soundproofing
- 85-96 Abrasives
- 97-106 Masking systems
- 107-118 Polishing
- 119-126 OHS
- 127-132 Fabric filters and spray-painting booth accessories
- 133-154 Workshop auxiliary equipment
- 155-170 Various spray-painting products
- 171-178 Spray guns and extruders
- 179-186 Pneumatic grinders
- 187-192 Electric grinders, heat guns and lamps
- 193-198 Work disks
- 199-204 Dust extraction
- 205-208 Radiators
- 209-218 Pneumatics
- 219-222 Spray gun regenerators and washers
- 223-232 Technical sprays

• APP MS Polymer

Spray-on polymer mass

APP MS Polymer is a permanently elastic, spray-on, polymer sealing mass intended for use in car body repairs. It features excellent adhesion to: glass, stainless steel, anodized aluminum, lacquered and enameled surfaces, fiberglass reinforced plastic materials. It can be covered with top coat paints and lacquers used in car body repairs.

➤ ADVANTAGES

- ready to paint after 25 minutes
- resistance to UV radiation
- possibility to apply with a roller, spray, and with a brush
- thermal resistance: from -40°C to +100°C

APP NO.	Packaging	Color	Volume	Col. Pack.
040403	cartridge	grey	310 ml	12 pcs.
040404	cartridge	yellow	310 ml	12 pcs.
040405	cartridge	black	310 ml	12 pcs.
040406	cartridge	beige RAL 1015	310 ml	12 pcs.



25 min / +20°C



• APP PU 50

Polyurethane adhesive and sealing mass

APP PU 50 is a one-component, permanently elastic, quick-drying, polyurethane, extruded adhesive and sealing mass with high viscosity. It is intended for use in car body repairs and for many interior and exterior industrial applications in low temperatures. The product is ready to be covered with top coat paints and lacquers for car body repairs.

➤ ADVANTAGES

- the mass has all the required maritime certificates
- it is a watertight sealant and adhesive for smooth and porous surfaces
- enables elastic gluing of metal and plastic materials
- can be applied using a roller or spread with a brush
- thermal resistance: from -40°C to +90°C

APP NO.	Packaging	Color	Volume	Col. Pack.
040301	closed cartridge	white	310 ml	12 pcs.
040302	closed cartridge	grey	310 ml	12 pcs.
040303	closed cartridge	black	310 ml	12 pcs.
040304	closed cartridge	yellow	310 ml	12 pcs.
040311	bag	grey	600 ml	20 pcs.
040312	bag	black	600 ml	20 pcs.
040305	open cartridge	white	310 ml	12 pcs.
040306	open cartridge	grey	310 ml	12 pcs.
040307	open cartridge	black	310 ml	12 pcs.
040314	bag	grey	600 ml	12 pcs.
040315	bag	black	600 ml	12 pcs.



2690



• APP Auto Glass

Car windshield installation adhesive

APP Auto Glass is a one-component, polyurethane adhesive and sealing mass with very good viscosity, intended for installing car windshields. The adhesive cures in contact with atmospheric moisture, creating a waterproof, elastic seam that has excellent vibration absorption properties. The adhesive is certified under the FMVSS 212 safety attestation.

➤ Readiness to drive after installing the front windshield:

- 4 hours for a vehicle without airbags
- 6 hours for a vehicle with airbags

APP NO.	Packaging	Color / Option	Volume	Col. Pack.
040501	cartridge	normal	310 ml	12 pcs.



• APP Auto Glass GTX

Quick car windshield installation adhesive

APP Auto Glass GTX is a quick, one-component, polyurethane adhesive and sealing mass with very good viscosity, intended for installing car windshields. The adhesive cures in contact with atmospheric moisture, creating a waterproof, elastic seam that has excellent vibration absorption properties. The adhesive is certified under the FMVSS 212 safety attestation.

➤ Readiness to drive after installing the front windshield:

- 1,5 hours for a vehicle without airbags
- 3 hours for a vehicle with airbags

APP NO.	Packaging	Color / Option	Volume	Col. Pack.
040531	cartridge	fast	310 ml	12 pcs.



• APP Primer KM

Primer for windshield installation adhesive

APP Primer KM is a primer for the installation of car windshields using polyurethane adhesives APP Auto Glass and APP Auto Glass GTX. It is intended to activate and increase the adhesion of the applied glue and secure the seam against UV radiation.

➤ ADVANTAGES

- short drying time of 10-15 minutes
- extends the time to apply the glue to 1 hour
- primer and activator all in one

APP NO.	Packaging	Volume	Col. Pack.
040610	tube	10 ml	12 pcs.
040611	bottle	30 ml	25 pcs.
040612	bottle	250 ml	12 pcs.



• APP SLP 99

Rearview mirror installation adhesive

APP SPL 99 is a one-component, medium-viscosity adhesive for use with a catalytic foil. It is intended for gluing a rearview mirror to a car's front windshield and metal elements, such as grips for tilting side windows.

➤ ADVANTAGES

- easy to use
- compensates for variable thermal expansion of glass and metal

APP NO.	Packaging	Volume	Col. Pack.
040504	applicator	1 ml	12 pcs.



• APP SEAL10

Adhesive and sealing mass for brush application

APP Seal 10 is a one-component, permanently elastic, rubber sealing mass for brush application. Intended for use on raw and primed car body panels and surfaces covered with bases and top coat lacquers. After drying, the mass can be covered with a one- or two-component paint or lacquer intended for car body refinishing works.

➤ ADVANTAGES

- can be used on raw, unprocessed bodywork panels
- can be painted over after drying
- provides an original, factory sealing texture with visible brush streaks
- thermal resistance from -30°C to +80°C

APP NO.	Packaging	Color / Option	Volume / Weight	Col. Pack.
040101	can	light grey	1 kg	12 pcs.



1-2 x 1



2-3 h / +20°C

VOC/LZO 2004/42/EC- II B (e)(840): 348 g/l



• APP SEAL12

Adhesive and sealing mass for brush application

APP Seal 12 is a quick-drying, one-component, permanently elastic, rubber sealing mass for brush application. Intended for use on raw and primed car body panels and surfaces covered with bases and top coat lacquers. After drying, the mass can be covered with a one- or two-component paint or lacquer intended for car body refinishing works.

➤ ADVANTAGES

- short drying time.
- can be used on raw, unprocessed bodywork panels.
- can be painted over after drying.
- provides an original, factory sealing texture with visible brush streaks.
- thermal resistance from -30°C to +80°C.

APP NO.	Packaging	Color / Option	Volume / Weight	Col. Pack.
040105	can	dark grey	1 kg	6 pcs.



1-2 x 1



1-1,5 h / +20°C

VOC/LZO 2004/42/EC- II B (e)(840): 407,29 g/l



• APP ButylTape

Sealing tape

APP ButylTape is a synthetic, self-adhesive sealant made from a butyl mass. Thanks to its high elasticity, it very easily adapts to the shape of the surface. It is characterized by wide application in the automotive industry, construction, and ventilation, heating and air conditioning systems.

> ADVANTAGES

- high elasticity throughout the entire exploitation period
- good resistance to UV radiation
- good adhesion to various types of substrates
- high comfort of use, allows disassembly of the sealed elements
- temperature resistance from - 40°C to + 90°C

APP NO.	Color / Type	Volume	Sales unit
040711	grey / flat tape	20 mm x 2 mm x 22,5 m	pcs.
040712	black / roll tape	8 mm x 6 m	(pack.3 pcs.)



• APP M GUM

Exhaust system installation paste

APP M GUM is an essential sealant intended for local sealing of exhaust system segment connections. Manufactured on the basis of water glass, with a nearly unnoticeable odor, it has a putty structure with a dark grey color. Curing takes place in contact with high temperatures generated in the exhaust system during the vehicles normal exploitation.

> ADVANTAGES

- guarantees easy disassembly of exhaust system segments even after a long period of exploitation
- easy and quick application

APP NO.	Volume / Weight	Col. Pack.
041110	170 g	12 pcs.



• APP R GUM

Quick muffler repair paste

APP R GUM is an essential compound for quick repairs of leaky exhaust systems. It has the consistency of putty with a dark grey color. Manufactured based on silicates and intended for local sealing of cracks, holes and perforations in the exhaust system.

> ADVANTAGES

- paste cured in contact with high temperatures generated in the vehicle's exhaust system
- easy and quick application
- water-dilutable product

APP NO.	Volume / Weight	Col. Pack.
041115	200 g	12 pcs.



• APP PRG50

Polyurethane plastic material adhesive

APP PRG 50 is a two-component, black-colored, polyurethane adhesive essential in the glue repair of a wide range of materials made from plastics, steel, aluminum, wood and glass. It is characterized by a short curing time and high resistance to stress. The glue undergoes polymerization in ambient temperatures and is completely odorless. After curing, it can be subjected to mechanical processing and lacquering.

> APPLICATION

- joining plastic elements
- gluing of boat and yacht elements
- gluing of sports equipment
- repair of automotive details, spoilers and fairings
- gluing of electronic equipment

APP NO.	Packaging	Color	Volume	Col. Pack.
220333	cartridge 2 x 25 ml	black	50 ml	12 pcs.



• APP C550

Cyanoacrylate glue for rubber and plastics

APP C550 is a cyanoacrylate glue characterized by high viscosity and short bonding time. It is resistant to moisture. The product does not contain solvents. The glue creates quick, clean, and nearly invisible bonds. It is intended for glue joints of highly porous (absorbent) materials such as rubber and plastics.

➤ ADVANTAGES

- quick and easy to use
- adhesion to highly porous and smooth surfaces
- resistant to aging, temperature, and many chemical compounds
- stable at low temperatures

APP NO.	Description	Weight / Volume	Col. Pack.
040507	high viscosity	20 g	30 pcs.



• APP C610

Cyanoacrylate glue for rubber and plastics and metal

APP C610 is a cyanoacrylate glue characterized by medium viscosity and very short bonding time. It is resistant to moisture. The product does not contain solvents. The glue creates quick, clean, and nearly invisible bonds. It is intended for glue joints of highly porous (absorbent) materials such as rubber and plastics and metal.

➤ ADVANTAGES

- quick and easy to use
- adhesion to smooth and porous surfaces
- resistant to aging, temperature, and many chemical compounds
- stable at low temperatures

APP NO.	Description	Weight / Volume	Col. Pack.
040509	medium viscosity	20 g	30 pcs.



• APP C630

Cyanoacrylate glue for rubber and plastics and EPDM

APP C630 is a cyanoacrylate glue characterized by low viscosity and very short bonding time. It is resistant to moisture. The product does not contain solvents. The glue creates quick, clean, and nearly invisible bonds. It is intended for glue joints of EPDM (e.g. o-rings) and certain plastic materials.

➤ ADVANTAGES

- quick and easy to use
- adhesion to smooth and absorbent surfaces
- resistant to aging, temperature, and many chemical compounds
- stable at low temperatures

APP NO.	Description	Weight / Volume	Col. Pack.
040511	low viscosity	20 g	30 pcs.



• APP K55 Spray

Universal adhesive

APP K 55 Spray is a quick and universal spray adhesive intended for use in motor vehicles, crafts, modelling, and household applications. It enables joining leather and natural or synthetic fabrics, gluing floor linings, papier, cardboard, polyurethane foams, foil, wood, and wood derivatives. The joined elements should be glued together within 5-15 minutes from applying the glue, depending on the materials used. This is a significant advantage in case of larger working surfaces, e.g. gluing roof linings.

➤ ADVANTAGES

- broad range of applications
- adhesion to smooth and porous surfaces
- thick consistency that does not permeate the joined surfaces
- thermal resistance after curing: from -20°C to +45°C
- wide-angle, rotating nozzle enabling precise application
- does not contain DCM (dichloromethane) – a carcinogenic substance

APP NO.	Weight / Volume	Col. Pack.
040505	400 ml	12 pcs.



• APP KIT EP

2K Epoxy filler

APP EP is a quick-bonding, two-component epoxy putty for filling surface defects in metals, ceramics, and certain plastic materials with the exception of PP, PE, PTFE and silicone derivatives. It also enables sealing and gluing. Due to the high degree of hardness after curing, the filling is suited to mechanical processing (grinding, drilling, cutting with a saw, milling).

➤ ADVANTAGES

- universal and easy to use
- high degree of filling hardness
- intended for mechanical processing

APP NO.	Weight / Volume	Col. Pack.
040516	50 g	20 pcs.



• APP EP3

2K Epoxy adhesive

APP EP3 is a colorless, two-component epoxy adhesive. It effectively joins ceramics, glass, metal, and certain plastics. After curing, it forms a tensile and impact resistant bond that can also withstand contact with water and most solvents

➤ ADVANTAGES

- hardens after 5 minutes
- resistant to water and most solvents
- available in practical, double syringe applicators
- thermal resistance up to +100°C

APP NO.	Weight / Volume	Col. Pack.
040515	2 x 15 ml	20 pcs.



• APP M2

2K Liquid Metal

APP M2 is a two-component, metallic, epoxy adhesive and paintable filler. It is intended for repairs of metal and ceramic surfaces, as well as surfaces of certain plastic materials. Achieves high mechanical strength after curing. The product is intended for mechanical processing (grinding, drilling, cutting with a saw, milling).

➤ ADVANTAGES

- cures after 5 minutes
- mechanical processing possible after curing
- thermal resistance up to +100°C

APP NO.	Weight / Volume	Col. Pack.
040518	2 x 20g	12 pcs.



• APP Emblem Tape

Emblem tape

APP Emblem Tape is a universal, transparent acrylic tape enabling the gluing of letters, emblems, and company signs on the car body surface. It is resistant to the effects of weather. The applied acrylic glue guarantees high resistance to shear stress, adhesion durability, and resistance to washing in a car wash.

➤ ADVANTAGES

- transparent and colorless
- very good resistance to UV radiation
- very good moisture resistance
- thermal resistance from -30°C to +90° C

APP NO.	Description	Weight / Volume	Sales unit
040920	sheet	100 x 200 mm	set (5 pcs.)





• APP TD Super

Two-sided adhesive tape

APP TD Super is a two-sided, foam adhesive tape intended for installing side moldings and decorative elements, as well as for permanently joining elements made from various materials. It is characterized by good mechanical strength, resistance to weather conditions and variable temperatures.

➤ ADVANTAGES

- very good resistance to UV radiation
- features soundproofing and sealing properties
- compensates for unevenness on joined surfaces
- compensates for vibrations
- thermal resistance from -20°C to +120°C

APP NO.	Color	Weight / Volume	Col. Pack.
040810	blue	6 mm x 5 m	132 pcs.
040811	blue	9 mm x 5 m	96 pcs.
040812	blue	12 mm x 5 m	80 pcs.
040813	blue	19 mm x 5 m	48 pcs.
040814	blue	25 mm x 5 m	36 pcs.
040820	blue	6 mm x 10 m	160 pcs.
040821	blue	9 mm x 10 m	116 pcs.
040822	blue	12 mm x 10 m	90 pcs.
040823	blue	19 mm x 10 m	60 pcs.
040824	blue	25 mm x 10 m	44 pcs.



• APP Acryl Tape

Two-sided acrylic adhesive tape

APP Acryl Tape is a two-sided, acrylic adhesive tape for interior and exterior applications, with increased mechanical strength. It is intended for permanent fastening of side moldings and decorative elements, and for use as a sealing material. It is able to substitute welding, liquid gluing, and other permanent bonding compounds.

➤ ADVANTAGES

- adhesion to many types of surfaces
- good resistance to UV radiation
- very good moisture resistance
- thermal resistance from -30°C to +120°C

APP NO.	Color	Weight / Volume	Col. Pack.
040916	red	6 mm x 5 m	14 pcs.
040910	red	9 mm x 5 m	14 pcs.
040911	red	12 mm x 5 m	14 pcs.
040912	red	19 mm x 5 m	14 pcs.
040917	red	6 mm x 10 m	14 pcs.
040913	red	9 mm x 10 m	14 pcs.
040914	red	12 mm x 10 m	14 pcs.
040915	red	19 mm x 10 m	14 pcs.



• APP TM 10

Transparent, two-sided installation tape

APP TM 10 is a transparent, thin, two-sided, adhesive installation tape with a high adhesive strength. It is intended for interior and exterior applications. Resistant to UV radiation, moisture, and difficult weather conditions.

➤ ADVANTAGES

- adhesion to many types of surfaces
- very good resistance to UV radiation
- sealing function
- very good moisture resistance
- thermal resistance from -30°C to +100°C

APP NO.	Color	Weight / Volume	Col. Pack.
040904	transparent	12 mm x 10 m	10 pcs.



SPRAY-PAINTING

1



Car body protection
and soundproofing

21-232 SPRAY-PAINTING

- 21-28 Putties and fillers
- 29-36 Base and primers
- 37-46 Top coats
- 47-56 Modular color selection system
- 57-62 Thinners, removers and additives
- 63-67 Repair of plastics
- 69-76 Adhesives and sealants
- 77-84 • Car body protection and soundproofing**
- 85-96 Abrasives
- 97-106 Masking systems
- 107-118 Polishing
- 119-126 OHS
- 127-132 Fabric filters and spray-painting booth accessories
- 133-154 Workshop auxiliary equipment
- 155-170 Various spray-painting products
- 171-178 Spray guns and extruders
- 179-186 Pneumatic grinders
- 187-192 Electric grinders, heat guns and lamps
- 193-198 Work disks
- 199-204 Dust extraction
- 205-208 Radiators
- 209-218 Pneumatics
- 219-222 Spray gun regenerators and washers
- 223-232 Technical sprays

APP C300 Predator

Two-component, polyurethane, structural protective coating 3:1

APP C 300 Predator is a two-component, polyurethane-acrylic, structural protective coating characterized by high resistance to scratches. It is intended for long-term protection against mechanical and chemical damage of locations exposed to the most adverse physical and environmental conditions.



ADVANTAGES

- easy application – simple texture adjustment
- high hardness, elasticity and chemical resistance
- high mechanical resistance to impacts, scratches, abrasion, etc.
- active corrosion protection thanks to incorporation of anti-corrosion pigments
- resistance to UV radiation and atmospheric factors
- adhesion to difficult surfaces without the need for priming
- can be covered with APP Modular Special Base and APP Modular Acryl Line, and other water-dilutable and conventional top coat lacquers
- thermal resistance up to +85°C

C300 Predator

Two-component, polyurethane, structural protective coating

APP NO.	Packaging	Color / Option	Volume	Sales unit
050700	can	black	600 ml	12 pcs.

Harter C300 Predator

Curing agent for two-component, polyurethane, structural protective coating

APP NO.	Packaging	Volume	Sales unit
050701	can	200 ml	12 pcs.

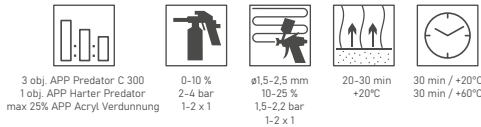

APP Tint Predator

Two-component, polyurethane, structural protective coating for tinting 3:1

APP Tint Predator is a two-component, polyurethane-acrylic, structural protective coating intended for tinting with any chosen acrylic lacquer in the APP Modular Acryl Line. APP Tint Predator allows application of a coating in a chosen color, which is characterized by very high scratch resistance. It is intended for long-term protection against mechanical and chemical damage and against corrosion.



ADVANTAGES

- ability to apply a protective coating in any chosen color
- easy application – simple texture adjustment
- high hardness, elasticity and chemical resistance
- high mechanical resistance to impacts, scratches, abrasion, etc.
- active corrosion protection thanks to incorporation of anti-corrosion pigments
- resistance to UV radiation and atmospheric factors
- adhesion to difficult surfaces without the need for priming
- thermal resistance up to +85°C

Tint Predator

Two-component, polyurethane, structural protective coating

APP NO.	Packaging	Color / Option	Volume	Sales unit
050702	can	for tinting	600 ml	12 pcs.

Harter C300 Predator

Curing agent for two-component, polyurethane, structural protective coating

APP NO.	Packaging	Volume	Sales unit
050701	can	200 ml	12 pcs.

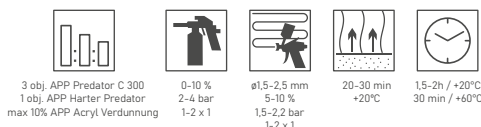

• APP U100 UBS

VOC/LZO 2004/42/EC- II B (e)(840): 410 g/l

Preparation for bodywork protection against stone impacts

APP U100 UBS is an elastic, spray-on rubber mass with a high solid particle Volume. It is intended for protection against impact from stones and corrosion protection of vehicle bodywork. The product has soundproofing properties. The obtained coating can be painted over with any type of top coat paint or lacquer.

➤ ADVANTAGES

- features a classic dashed texture
- ready to be painted over after 60 minutes
- product ready to use after mixing
- very good adhesion to many substrates
- does not contain bituminous substances or asphalt

APP NO.	Packaging	Color / Option	Weight	Sales unit
050099	can	black	1 kg	12 pcs.
050100	can	grey	1 kg	12 pcs.



• APP U100 UBS Spray

Preparation for bodywork protection against stone impacts

APP U100 UBS Spray is a quick-drying, elastomer, spray-on mass with insulating and soundproofing properties. It is intended for protecting and securing the chassis, side sills, wheel arches, spoilers, lower parts of doors, and other car bodywork elements against mechanical damage and adverse weather conditions.

➤ ADVANTAGES

- easy to use, elastic and quick-drying
- the obtained protective coating has a classic dashed texture and can be painted over with any type of top coat paint or lacquer
- the nozzle and tube allow to obtain a highly textured coating and allows to access difficult to reach areas
- has anti-corrosion and soundproofing properties
- does not contain bituminous substances or asphalt

APP NO.	Packaging	Color / Option	Volume	Sales unit
050090	aerosol	black	500 ml	12 pcs.



• APP U200 UBS

VOC/LZO 2004/42/EC- II B (e)(840): 534,9 g/l

Preparation for bodywork protection against stone impacts

APP U200 UBS is an elastic, spray-on rubber mass intended for protection against impact from stones and long-term corrosion protection. The product protects the car body panels against the effects of saline water, as well as acids and bases in low concentrations. It also has soundproofing properties.

➤ ADVANTAGES

- salt solution resistance test compliant with the DIN35167 norm: 1000 hours
- product ready to use after mixing
- after drying, the product has a nearly smooth surface with a minor texture
- very good adhesion to many substrates
- the obtained coating can be painted over with any type of top coat paint or lacquer

APP NO.	Packaging	Color / Option	Volume	Sales unit
050101	can	black	1,0 L	12 pcs.
050102	can	grey	1,0 L	12 pcs.
050103	can	white	1,0 L	12 pcs.



• APP U200 UBS Spray

VOC/LZO 2004/42/EC- II B (e)(840): <580 g/l

Preparation for bodywork protection

APP U200 UBS Spray is a spray-on mass manufactured based on synthetic rubber. It protects the car body surface against impacts from stones and gravel. With its anti-corrosion properties, the product can also be used to protect car body panels against the effects of saline water, acids and bases in low concentrations.

➤ ADVANTAGES

- easy and universal application
- ready to be painted over after drying
- does not require special gear
- provides a smooth texture after drying

APP NO.	Packaging	Color / Option	Volume	Sales unit
050204	aerosol	black	500 ml	6 pcs.
050205	aerosol	grey	500 ml	6 pcs.
050206	aerosol	white	500 ml	6 pcs.



• APP U210 2w1

VOC/LZO 2004/42/EC - II B (e) (840): 559,8 g/l

Preparation for bodywork protection against stone impacts + spray-on mass

APP U210 2 in 1 is a spray-on mass manufactured based on synthetic rubber intended to protect the car's bodywork against stone impacts and to seal welding seams, optically recreating the factory texture. The product secures bodywork panels against the effects of saline water, as well as acids and bases in low concentrations. It also has soundproofing properties.

➤ ADVANTAGES

- obtains a tall and sharp texture after drying
- the mass may be used as a dashed textured layer (UBS) or spray-on sealant
- during curing, the obtained surface remains nearly unchanged
- the obtained protective coating can be painted over with any type of top coat paint or lacquer

APP NO.	Packaging	Color / Option	Weight	Sales unit
050110	can	black	1 kg	12 pcs.
050111	can	grey	1 kg	12 pcs.

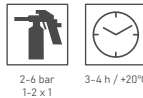

2-6 bar
1-2 x 1

3-4 h / +20°C



• APP F400 Profil

Closed profile protection compound

VOC/LZO 2004/42/EC - II B (e) (840): 528,4 g/l

APP F400 Profil is a permanently elastic preparation based on mineral oil, paraffin wax, and impregnating additives for corrosion protection of closed profiles and difficult to reach areas of car bodyworks, such as: bodywork beams and doors, as well as engine and trunk compartments.

➤ ADVANTAGES

- features penetrating and water displacing properties
- product ready to use after mixing
- wax colors compatible with factory colors
- salt solution resistance test compliant with the test DIN 53210 norm: 1000 hours

APP NO.	Packaging	Color / Option	Volume	Sales unit
050301	can	amber	1,0 L	12 pcs.
050302	can	transparent	1,0 L	12 pcs.

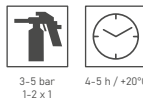

3-5 bar
1-2 x 1

4-5 h / +20°C



• APP F400 Profil Spray

Closed profile protection compound

VOC/LZO 2004/42/EC - II B (e) (840): 522,3 g/l

APP F400 Profil Spray is a permanently elastic, water-repellent preparation based on mineral oil, paraffin wax and impregnating additives for corrosion protection of closed profiles and difficult to reach areas of car bodyworks, such as: bodywork beams and doors, as well as engine and trunk compartments.

➤ ADVANTAGES

- easy and universal application
- product ready to use after mixing
- features penetrating and water displacing properties
- wax colors compatible with factory colors
- the spray features a probe that allows to apply the compound in difficult to reach areas

APP NO.	Packaging	Color / Option	Volume	Sales unit
050401	aerosol with probe	amber	500 ml	12 pcs.
050402	aerosol with probe	transparent	500 ml	12 pcs.



• APP F410 Profil Spray

Closed profile protection compound

APP F410 Profil Spray is an anti-corrosion, permanently elastic preparation based on wax and impregnating additives intended for corrosion protection of closed profiles and difficult to reach areas of car bodyworks. After evaporation of the solvent, it forms a consistent, elastic and viscous protective coating.

➤ ADVANTAGES

- easy and universal application
- product ready to use after mixing
- features penetrating and water displacing properties
- the coating can re-seal itself during exploitation
- the spray features a probe that allows to apply the compound in difficult to reach areas

APP NO.	Packaging	Color / Option	Volume	Sales unit
050405	aerosol with probe	amber	500 ml	12 pcs.
050406	aerosol with probe	transparent	500 ml	12 pcs.



3-5 bar
1-2 x 1



1,5 h / +20°C



• APP W100 WAX

Wax-based chassis protection compound

APP W100 Wax is a wax-based preparation for corrosion protection of the chassis of passenger cars, busses and commercial vehicles. Characterized by very good adhesion to PVC, the product is intended to enhance the factory chassis protection in new cars, as well as restore corrosion protection following bodywork repairs. It creates a permanently elastic, water-repellent coating with very good adhesion to the surface.

➤ ADVANTAGES

- features penetrating and water displacing properties
- product ready to use after mixing
- very good adhesion to PVC, rubber/resin, rubber/bitum and waxes
- resistance test in a saline chamber: 1000 hours

APP NO.	Packaging	Color / Option	Volume	Sales unit
050502	can	anthracite	1,0 L	12 pcs.



3-5 bar
1-2 x 1



4-6 h / +20°C



• APP W100 WAX Spray

Wax-based chassis protection compound

APP W100 Wax Spray is a wax-based preparation for quick repairs of corrosion protection layers in the chassis of passenger cars, busses and commercial vehicles. It creates a permanently elastic coating with very good adhesion to the surface.

➤ ADVANTAGES

- features penetrating and water displacing properties
- product ready to use after mixing
- very good adhesion to PVC
- does not require special gear

APP NO.	Packaging	Color / Option	Volume	Sales unit
050501	aerosol	anthracite	500 ml	12 pcs.



• APP B 220 Autobit

Bituminous chassis protection compound

APP B 220 Autobit is an elastic bituminous mass intended for chassis maintenance, corrosion protection, and protection against stone impacts. Thanks to its properties, the product may be applied in thick layers while simultaneously retaining its elasticity. It forms a durable anti-corrosion coating on the chassis of passenger and commercial cars, machines and other equipment with chassis exposed to the effects of adverse weather conditions.

➤ ADVANTAGES

- does not require specialized tools, intended for application with a brush
- sable and elastic even in thick layers
- very good corrosion protection (addition of anti-corrosion pigments)
- increased product efficiency due to a high, 77% Volume of solid particles

APP NO.	Packaging	Color / Option	Weight	Sales unit
050811	can	for brush application	1,3 kg	12 pcs.
050812	can	for brush application	2,5 kg	6 pcs.



• APP B 200 Autobit

Bituminous chassis protection compound

APP B 200 Autobit is an elastic bituminous mass intended for chassis maintenance, corrosion protection, and protection against stone impacts. Thanks to its properties, the product may be applied in thick layers while simultaneously retaining its elasticity. It forms a durable anti-corrosion coating on the chassis of passenger and commercial cars, machines and other equipment with chassis exposed to the effects of adverse weather conditions.

➤ ADVANTAGES

- product ready to use after mixing
- sable and elastic even in thick layers
- very good corrosion protection (addition of anti-corrosion pigments)
- increased product efficiency due to a high, 65% Volume of
- resistance test in a saline chamber according to the DIN50021 norm: 1000 hours

APP NO.	Packaging	Color / Option	Volume	Sales unit
050611	can	black / natrysk	1,0 L	12 pcs.

VOC/LZO 2004/42/EC - II B (e) (840): 376,3 g/l



• APP B120 Autobit

APP B120 Autobit

APP B120 Autobit is a bituminous mass for brush application with anti-corrosion and sound dampening properties. It forms an elastic, thermal insulating layer that protects against the effects of adverse weather conditions. The product is intended to provide corrosion protection for the chassis of passenger and commercial cars, construction machines and other equipment, as well as protection against impact in the wheel arches.

➤ ADVANTAGES

- salt solution resistance test: 500 hours
- extreme anti-corrosion barrier with long-lasting elasticity
- very good adhesion to many substrates
- compatible with original PVC coatings
- easy and universal application

APP NO.	Packaging	Color / Option	Weight	Sales unit
050801	can	black	1,3 kg	12 pcs.
050802	can	black	2,5 kg	6 pcs.



• APP B100 Autobit

Bituminous chassis protection compound

APP B100 Autobit is a spray-on bituminous mass with anti-corrosion and sound dampening properties intended for protecting the chassis of passenger and commercial cars, and construction machines. It is recommended for protection against stone impacts in the wheel arches, as well as repair of already existing anti-corrosion measures. It forms an elastic, thermal insulation layer protecting against adverse weather effects.

➤ ADVANTAGES

- elastic bituminous product
- product ready to use after mixing
- no tendency to drip while spraying
- extreme anti-corrosion barrier
- resistance test in a saline chamber according to the DIN 50021 norm: 700 hours

APP NO.	Packaging	Color / Option	Volume	Sales unit
050601	can	black /spray	1,0 L	12 pcs.

VOC/LZO 2004/42/EC - II B (e) (840): 455,8 g/l



• APP MW 500 T

Sound dampening mat - hard

APP MW 500 T is a self-adhesive, hard, bituminous soundproofing mat. It is intended to dampen sounds, vibrations, and stiffen large surfaces of bodywork panels in places where high rigidity is required, such as doors, rear fenders, trunk interiors and the floor. The mat can be formed after heating. Other applications include: farming and construction machinery, elevator cages, home appliances, air conditioners, metal furniture, kitchen sinks, etc.

➤ ADVANTAGES

- fits to rigid surfaces
- good forming ability after heating
- can be coated with paint or lacquer after removing the protective foil

APP NO.	Dimensions	Sales unit
050902	250 x 500mm	pack. (20 pcs.)



• APP MW 500 M

Sound dampening mat - soft

APP MW 500 M is a self-adhesive, soft, bituminous soundproofing mat. It is intended to dampen sounds, vibrations in places that require high elasticity, such as car interior and trunk floors, and wheel arches. The mat can be formed in room temperature or after heating. Other applications include: farming and construction machinery, elevator cages, home appliances, air conditioners, metal furniture, kitchen sinks, etc.

➤ ADVANTAGES

- optimally adapts to the surface
- very good forming ability after heating
- can be coated with paint or lacquer after removing the protective foil

APP NO.	Dimensions	Sales unit
050901	500 x 500mm	pack. (10 pcs.)



• APP MW 500 HC

Sound dampening mat - soft HC

APP MW 500 HC is a self-adhesive, soft, bituminous soundproofing mat. It is intended to dampen sounds, vibrations in places that require high elasticity, such as car interior and trunk floors, and wheel arches. The mat can be formed in room temperature or after heating. Other applications include: farming and construction machinery, elevator cages, home appliances, air conditioners, metal furniture, kitchen sinks, etc.

➤ ADVANTAGES

- optimally adapts to the surface
- very good forming ability after heating
- can be coated with paint or lacquer after removing the protective foil

APP NO.	Dimensions	Sales unit
050905	500 x 500mm	pack. (10 pcs.)



• APP MW 500 DS

Sound dampening mat - soft DS

APP MW 500 DS is a self-adhesive, soft, bituminous soundproofing mat. It is intended to dampen sounds, vibrations in places that require high elasticity, such as car interior and trunk floors, and wheel arches. The mat can be formed in room temperature or after heating. Other applications include: farming and construction machinery, elevator cages, home appliances, air conditioners, metal furniture, kitchen sinks, etc.

➤ ADVANTAGES

- optimally adapts to the surface
- very good forming ability after heating
- can be coated with paint or lacquer after removing the protective foil

APP NO.	Dimensions	Sales unit
050906	500 x 500mm	pack. (10 pcs.)



• APP MW 500 P

Polymer sound dampening mat - smooth

APP MW 500 P is a self-adhesive, soft, polymer soundproofing mat. It is intended to dampen sounds, vibrations in places that require high elasticity, such as car interior and trunk floors, and wheel arches. The mat can be formed in room temperature or after heating. Other applications include: farming and construction machinery, elevator cages, home appliances, air conditioners, metal furniture, kitchen sinks, etc.

➤ ADVANTAGES

- optimally adapts to the surface
- very good forming ability after heating
- can be coated with paint or lacquer after removing the protective foil
- elastic even at low temperatures

APP NO.	Dimensions	Sales unit
050904	500 x 500mm	pack. (10 pcs.)



• APP MW 500 A

Sound dampening mat with aluminum layer

APP MW 500 A is a self-adhesive, bituminous soundproofing mat with an aluminum layer. It is intended for dampening sound and thermal insulation where it is required, for example, on the partition separating the car's interior from the engine compartment or on the duct above the exhaust system. The mat can be formed after heating. Other applications include: farming and construction machinery, home appliances, etc.

➤ ADVANTAGES

- adapts to the surface
- good thermal insulation

APP NO.	Dimensions	Sales unit
050903	500 x 500mm	pack. (10 pcs.)

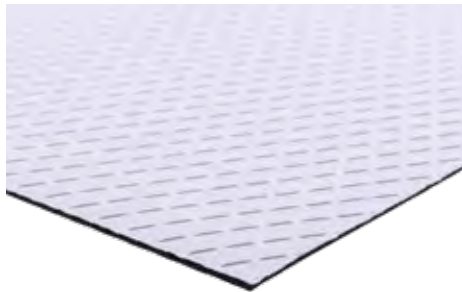

• APP MW 500 F

Sound dampening mat with felt

APP MW 500 F is a self-adhesive, bituminous soundproofing mat with felt layer and a total thickness of 10 mm. It is intended for dampening sound and thermal insulation in places where it is required. The mat can be formed after heating. Other applications include: farming and construction machinery, home appliances, etc.

➤ ADVANTAGES

- reduced oscillations and vibrations
- improves the acoustic space inside a vehicle
- good thermal insulation

APP NO.	Dimensions	Sales unit
050907	500 x 500mm	pack. (10 pcs.)

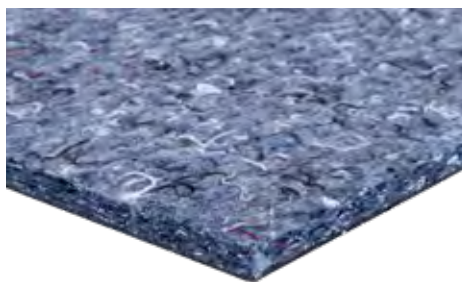

SPRAY-PAINTING

1



Abrasives

21-232 SPRAY-PAINTING

- 21-28 Putties and fillers
- 29-36 Base and primers
- 37-46 Top coats
- 47-56 Modular color selection system
- 57-62 Thinners, removers and additives
- 63-67 Repair of plastics
- 69-76 Adhesives and sealants
- 77-84 Car body protection and soundproofing
- 85-96 • Abrasives**
- 97-106 Masking systems
- 107-118 Polishing
- 119-126 OHS
- 127-132 Fabric filters and spray-painting booth accessories
- 133-154 Workshop auxiliary equipment
- 155-170 Various spray-painting products
- 171-178 Spray guns and extruders
- 179-186 Pneumatic grinders
- 187-192 Electric grinders, heat guns and lamps
- 193-198 Work disks
- 199-204 Dust extraction
- 205-208 Radiators
- 209-218 Pneumatics
- 219-222 Spray gun regenerators and washers
- 223-232 Technical sprays

• APP M991

Waterproof sandpaper

Waterproof sandpaper in 230 mm x 280 mm sheets intended for manual wet sanding. It can be used in all applications which require the highest quality of the sanded surface.

➤ ADVANTAGES

- the uniform, closed type coating allows for precise and even sanding of surfaces, creating an ideal substrate for top coat paints
- the incorporation of sharp silicon carbide grain enables particularly effective surface sanding
- the synthetic resin adhesive ensures maximum security against chipping of grains
- the elastic, impregnated paper with an anti-slip surface does not require initial, extended soaking

APP NO.	Description	Color	Dimensions	Sales unit	Col. Pack.
40MWM0060	P60	blue	230 mm x 280 mm	pack. (10 pcs.)	-
40MWM0080	P80	blue	230 mm x 280 mm	pack. (10 pcs.)	-
40MWM0100	P100	blue	230 mm x 280 mm	pack. (10 pcs.)	-
40MWM0120	P120	blue	230 mm x 280 mm	pack. (10 pcs.)	-
40MWM0150	P150	blue	230 mm x 280 mm	pack. (10 pcs.)	-
40MWM0180	P180	blue	230 mm x 280 mm	pack. (10 pcs.)	-
40MWM0220	P220	blue	230 mm x 280 mm	pack. (10 pcs.)	-
40MWM0240	P240	blue	230 mm x 280 mm	pack. (10 pcs.)	-
40MWM0280	P280	blue	230 mm x 280 mm	pack. (10 pcs.)	-
40MWM0320	P320	blue	230 mm x 280 mm	pack. (10 pcs.)	-
40MWM0360	P360	blue	230 mm x 280 mm	pack. (10 pcs.)	-
40MWM0400	P400	blue	230 mm x 280 mm	pack. (10 pcs.)	-
40MWM0500	P500	blue	230 mm x 280 mm	pack. (10 pcs.)	-
40MWM0600	P600	blue	230 mm x 280 mm	pack. (10 pcs.)	-
40MWM0800	P800	blue	230 mm x 280 mm	pack. (10 pcs.)	-
40MWM1000	P1000	blue	230 mm x 280 mm	pack. (10 pcs.)	-
40MWM1200	P1200	blue	230 mm x 280 mm	pack. (10 pcs.)	-
40MWM1500	P1500	blue	230 mm x 280 mm	pack. (10 pcs.)	-
40MWM2000	P2000	blue	230 mm x 280 mm	pack. (10 pcs.)	-
40MWM2500	P2500	blue	230 mm x 280 mm	pack. (10 pcs.)	-
40MWM3000	P3000	brown	230 mm x 280 mm	pack. (10 pcs.)	-
40MWM5000	P5000	brown	230 mm x 280 mm	pack. (10 pcs.)	-
40MWM7000	P7000	brown	230 mm x 280 mm	pack. (10 pcs.)	-
40MW0060	P60	blue	230 mm x 280 mm	pack. (50 pcs.)	10 pcs.
40MW0080	P80	blue	230 mm x 280 mm	pack. (50 pcs.)	10 pcs.
40MW0100	P100	blue	230 mm x 280 mm	pack. (50 pcs.)	10 pcs.
40MW0120	P120	blue	230 mm x 280 mm	pack. (50 pcs.)	10 pcs.
40MW0150	P150	blue	230 mm x 280 mm	pack. (50 pcs.)	10 pcs.
40MW0180	P180	blue	230 mm x 280 mm	pack. (50 pcs.)	10 pcs.
40MW0220	P220	blue	230 mm x 280 mm	pack. (50 pcs.)	10 pcs.
40MW0240	P240	blue	230 mm x 280 mm	pack. (50 pcs.)	10 pcs.
40MW0280	P280	blue	230 mm x 280 mm	pack. (50 pcs.)	10 pcs.
40MW0320	P320	blue	230 mm x 280 mm	pack. (50 pcs.)	10 pcs.
40MW0360	P360	blue	230 mm x 280 mm	pack. (50 pcs.)	10 pcs.
40MW0400	P400	blue	230 mm x 280 mm	pack. (50 pcs.)	10 pcs.
40MW0500	P500	blue	230 mm x 280 mm	pack. (50 pcs.)	10 pcs.
40MW0600	P600	blue	230 mm x 280 mm	pack. (50 pcs.)	10 pcs.
40MW0800	P800	blue	230 mm x 280 mm	pack. (50 pcs.)	10 pcs.
40MW1000	P1000	blue	230 mm x 280 mm	pack. (50 pcs.)	10 pcs.
40MW1200	P1200	blue	230 mm x 280 mm	pack. (50 pcs.)	10 pcs.
40MW1500	P1500	blue	230 mm x 280 mm	pack. (50 pcs.)	10 pcs.
40MW2000	P2000	blue	230 mm x 280 mm	pack. (50 pcs.)	10 pcs.
40MW2500	P2500	blue	230 mm x 280 mm	pack. (50 pcs.)	10 pcs.
40MW3000	P3000	brown	230 mm x 280 mm	pack. (50 pcs.)	10 pcs.
40MW5000	P5000	brown	230 mm x 280 mm	pack. (50 pcs.)	10 pcs.
40MW7000	P7000	brown	230 mm x 280 mm	pack. (50 pcs.)	10 pcs.



• APP MXR i APP MX

Waterproof sanding pads

– Velcro and glue fastened

Sanding pads intended for removing minor defects (dust dents and small water stains) on the surface of cured top coat paint and lacquers. They are used for spot finish sanding prior to polishing. The advantage of these pads is their undulating shape on the edges which, when properly placed on a block or work disk eliminates edge jamming, even during machine grinding using eccentric grinders. Intended for both manual and mechanical work.

APP NO.	Description	Fastening	Size	Single Pack.
40MX1500	P1500	glue	35 mm	12 pcs.
40MX2000	P2000	glue	35 mm	12 pcs.
40MX2500	P2500	glue	35 mm	12 pcs.
40MX5000	P5000	glue	35 mm	12 pcs.
150401	block	for glue	35 mm	1 pcs.
40MXR1500	P1500	velcro	35 mm	12 pcs.
40MXR2000	P2000	velcro	35 mm	12 pcs.
40MXR2500	P2500	velcro	35 mm	12 pcs.
150409	ALU block	glue + velcro	30 mm	1 pcs.

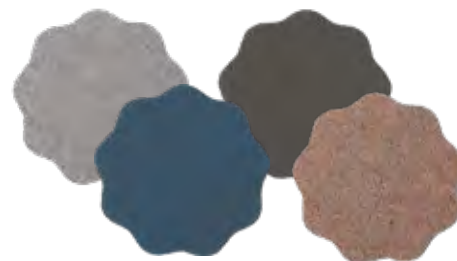

sanding pads



block



ALU block

• APP 991 AK 150 i APP 991 AK 75

Waterproof abrasive disk d150 and d75, Velcro fastened velcro

Velcro fastened, waterproof abrasive disks for mechanical wet grinding. Intended for mechanical removal of surface defects on cured lacquer prior to polishing. The abrasive material should be used in combination with a soft sponge or micro-rubber separator.

The grain size is designated by Velcro colors:

blue -P1500,
orange -P2000,
white -P2500.

➤ ADVANTAGES

- the uniform, closed type coating allows for precise and even sanding of surfaces, creating an ideal substrate for top coat paints
- the incorporation of sharp silicon carbide grain enables particularly effective surface sanding
- the synthetic resin adhesive ensures maximum security against chipping of grains

991 AK 150

APP NO.	Description	Color	Size	Sales unit
06MK1000	P1000	blue	d150	pack. (100 pcs.)
06MK1200	P1200	blue	d150	pack. (100 pcs.)
06MK1500	P1500	blue	d150	pack. (100 pcs.)
06MK2000	P2000	orange	d150	pack. (100 pcs.)
06MK2500	P2500	white	d150	pack. (100 pcs.)

991 AK 75

APP NO.	Description	Color	Size	Sales unit
06MD1500	P1500	blue	d75	pack. (100 pcs.)
06MD2000	P2000	orange	d75	pack. (100 pcs.)

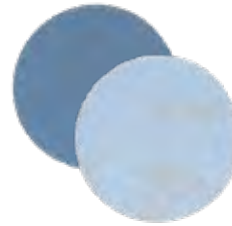

• APP PSK

Glue fastened abrasive pads on foil

Abrasive pads on a polyester foil base intended for removal of minor defects (dust dents and small water stains) on the surface of top coat lacquers. The new type grain coating made using the micro-replication method guarantees maximum precision and efficiency during work. The pads are intended for manual spot finish grinding prior to polishing, on APP KG MX or APP KA PSK blocks, and for mechanical work using the NTools PSM30 vibratory grinder. The pads can be used for dry as well as wet work when slightly moistened. Fastened to work blocks and disks using glue.

➤ ADVANTAGES

- remove minor painting defects thoroughly, quickly and precisely
- five times greater efficiency compared to pads with traditional grain coating
- do not clog during work and do not form springs
- create an even and easy to polish surface
- easy and quick use

APP NO.	Gradation	Fastening	Dimensions	Single Pack.
40PSK1500	P1500	glue	32 mm	12 pcs.
40PSK2000	P2000	glue	32 mm	12 pcs.
150409	ALU block	glue+velcro	32 mm	1 pcs.



• APP Carbon

Abrasive block

Pressed abrasive material for finish grinding prior to polishing. Intended for removal of inclusions, water stains and unevenness on cured painted surfaces and in paintless removal of dents (PDR – Paintless Dental Removal). For use on all types of cured top coat paints and lacquers.

APP NO.	Description	Color
06CAR0800	P0800	grey
06CAR1000	P1000	dark grey
06CAR1500	P1500	yellow
06CAR2000	P2000	green
06CAR3000	P3000	brown

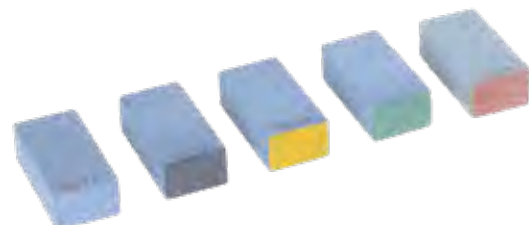

• APP QUARTZ Q401

Abrasive disk on foil d150, grey colored, 14+1 holes, Velcro fastened

The APP QUARTZ Q401 abrasive disks are high quality abrasive materials on a synthetic foil base. The durable abrasive grain made from fine artificial corundum in an open coating, covered with an excess of water-dilutable stearic compound enables efficient work on soft and dusting surfaces and materials of significant hardness, e.g. stainless steel. The abrasive disks are intended exclusively for dry work and fastened with Velcro.

▶ ADVANTAGES

- new type of stearic compound coating with very high clogging resistance
- low working temperature
- even and hard grain, resistant to dulling, ensures high grinding efficiency
- aggressive and efficient work in all gradations
- grain embedding resistant to chipping, high temperatures and high loads
- strong base resistant to tearing and edge delamination
- long working time
- very good surface finishing, e.g. for top coat lacquer or prior to polishing



APP QUARTZ Q401

Abrasive disk on foil 14+1 holes

APP NO.	Description	Color	Size	Sales unit
40FMQM0080	P80	grey	d150	pack. (10 pcs.)
40FMQM0100	P100	grey	d150	pack. (10 pcs.)
40FMQM0120	P120	grey	d150	pack. (10 pcs.)
40FMQM0150	P150	grey	d150	pack. (10 pcs.)
40FMQM0180	P180	grey	d150	pack. (10 pcs.)
40FMQM0220	P220	grey	d150	pack. (10 pcs.)
40FMQM0240	P240	grey	d150	pack. (10 pcs.)
40FMQM0280	P280	grey	d150	pack. (10 pcs.)
40FMQM0320	P320	grey	d150	pack. (10 pcs.)
40FMQM0360	P360	grey	d150	pack. (10 pcs.)
40FMQM0400	P400	grey	d150	pack. (10 pcs.)
40FMQM0500	P500	grey	d150	pack. (10 pcs.)
40FMQM0600	P600	grey	d150	pack. (10 pcs.)
40FMQM0800	P800	grey	d150	pack. (10 pcs.)
40FMQM1000	P1000	grey	d150	pack. (10 pcs.)
40FMQM1200	P1200	grey	d150	pack. (10 pcs.)
40FMQM1500	P1500	grey	d150	pack. (10 pcs.)
40FMQM2000	P2000	grey	d150	pack. (10 pcs.)
40FMQM2500	P2500	grey	d150	pack. (10 pcs.)

APP QUARTZ Q401

Krażek ścierny na folii 14+1 otworów

APP NO.	Description	Color	Size	Sales unit	Col. Pack.
40FMQ0080	P80	grey	d150	pack. (100 pcs.)	10
40FMQ0100	P100	grey	d150	pack. (100 pcs.)	10
40FMQ0120	P120	grey	d150	pack. (100 pcs.)	10
40FMQ0150	P150	grey	d150	pack. (100 pcs.)	10
40FMQ0180	P180	grey	d150	pack. (100 pcs.)	10
40FMQ0220	P220	grey	d150	pack. (100 pcs.)	10
40FMQ0240	P240	grey	d150	pack. (100 pcs.)	10
40FMQ0280	P280	grey	d150	pack. (100 pcs.)	10
40FMQ0320	P320	grey	d150	pack. (100 pcs.)	10
40FMQ0360	P360	grey	d150	pack. (100 pcs.)	10
40FMQ0400	P400	grey	d150	pack. (100 pcs.)	10
40FMQ0500	P500	grey	d150	pack. (100 pcs.)	10
40FMQ0600	P600	grey	d150	pack. (100 pcs.)	10
40FMQ0800	P800	grey	d150	pack. (100 pcs.)	10
40FMQ1000	P1000	grey	d150	pack. (100 pcs.)	10
40FMQ1200	P1200	grey	d150	pack. (100 pcs.)	10
40FMQ1500	P1500	grey	d150	pack. (100 pcs.)	10
40FMQ2000	P2000	grey	d150	pack. (100 pcs.)	10
40FMQ2500	P2500	grey	d150	pack. (100 pcs.)	10

• NTools HMF 7

Abrasive disk d150, yellow colored, 14+1 holes, Velcro fastened

NTools HMF 7 abrasive disks with a grain made from artificial corundum (aluminum oxide) coated with a stearic compound, on a base from reinforced, elastic, latex paper. The designed seven gradations from P80 to P400 ensure an optimized process of surface preparation for car bodywork repairs.

▶ ADVANTAGES

- compatible with all commercially available grinders with a Velcro work disk diameter of 150 mm and 14+1 holes for dust suction
- optimized price to efficiency ratio
- aggressive and efficient work in all gradations
- minimized number of grain size types to 7 adapted to car bodywork repair technology
- the very open grain coating and stearate minimize clogging of spaces between the grains, even on highly dusting surfaces
- the elastic, latex paper base is adapted to grinding on rounded profiles with the use of soft work disks

APP NO.	Description	Color	Size	Sales unit
40HMF080	P80	yellow	d150	pack. (10 pcs.)
40HMF120	P120	yellow	d150	pack. (10 pcs.)
40HMF150	P150	yellow	d150	pack. (10 pcs.)
40HMF180	P180	yellow	d150	pack. (10 pcs.)
40HMF240	P240	yellow	d150	pack. (10 pcs.)
40HMF320	P320	yellow	d150	pack. (10 pcs.)
40HMF400	P400	yellow	d150	pack. (10 pcs.)
40HMF080	P80	yellow	d150	pack. (50 pcs.)
40HMF120	P120	yellow	d150	pack. (100 pcs.)
40HMF150	P150	yellow	d150	pack. (100 pcs.)
40HMF180	P180	yellow	d150	pack. (100 pcs.)
40HMF240	P240	yellow	d150	pack. (100 pcs.)
40HMF320	P320	yellow	d150	pack. (100 pcs.)
40HMF400	P400	yellow	d150	pack. (100 pcs.)

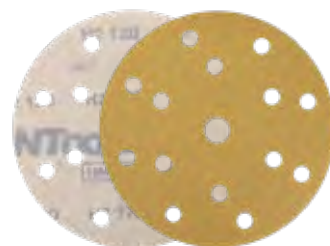

• APP K555

Abrasive disk d150, yellow colored, 14+1 holes, Velcro fastened

APP K555 abrasive disk with an artificial corundum (aluminum oxide) grain on an elastic base made from D and C latex paper, intended for mechanical grinding of medium hard and highly dusting polyester, acrylic, polyurethane and wooden surfaces using electric and pneumatic grinders with a dust suction function.

› ADVANTAGES

- very hard and even grain resistant to dulling
- an additional layer of stearate (P150-P800) – guarantees very high resistance to clogging of spaces between grains, ensures high efficiency, reduces temperature and mitigates vibrations during grinding
- open type grain coating – ensures very good suction of spoil while grinding medium hard surfaces with a high amount of generated dust and low working temperature
- elastic and smooth latex paper base optimizes work on profiled and flat surfaces during finishing works
- extended grinding time thanks to an optimal bonding of abrasive grains in an open type coating with the anti-clogging layer



APP NO.	Description	Color	Size	Sales unit	Col. Pack.
40KZUM0040	P40	yellow	d150	pack. (10 pcs.)	-
40KZUM0060	P60	yellow	d150	pack. (10 pcs.)	-
40KZUM0080	P80	yellow	d150	pack. (10 pcs.)	-
40KZUM0100	P100	yellow	d150	pack. (10 pcs.)	-
40KZUM0120	P120	yellow	d150	pack. (10 pcs.)	-
40KZUM0150	P150	yellow	d150	pack. (10 pcs.)	-
40KZUM0180	P180	yellow	d150	pack. (10 pcs.)	-
40KZUM0220	P220	yellow	d150	pack. (10 pcs.)	-
40KZUM0240	P240	yellow	d150	pack. (10 pcs.)	-
40KZUM0280	P280	yellow	d150	pack. (10 pcs.)	-
40KZUM0320	P320	yellow	d150	pack. (10 pcs.)	-
40KZUM0360	P360	yellow	d150	pack. (10 pcs.)	-
40KZUM0400	P400	yellow	d150	pack. (10 pcs.)	-
40KZUM0500	P500	yellow	d150	pack. (10 pcs.)	-
40KZUM0600	P600	yellow	d150	pack. (10 pcs.)	-
40KZUM0800	P800	yellow	d150	pack. (10 pcs.)	-

APP NO.	Description	Color	Size	Sales unit	Col. Pack.
40KZU040	P40	yellow	d150	pack. (50 pcs.)	10
40KZU060	P60	yellow	d150	pack. (50 pcs.)	10
40KZU080	P80	yellow	d150	pack. (50 pcs.)	10
40KZU100	P100	yellow	d150	pack. (50 pcs.)	10
40KZU120	P120	yellow	d150	pack. (50 pcs.)	10
40KZU150	P150	yellow	d150	pack. (100 pcs.)	10
40KZU180	P180	yellow	d150	pack. (100 pcs.)	10
40KZU220	P220	yellow	d150	pack. (100 pcs.)	10
40KZU240	P240	yellow	d150	pack. (100 pcs.)	10
40KZU280	P280	yellow	d150	pack. (100 pcs.)	10
40KZU320	P320	yellow	d150	pack. (100 pcs.)	10
40KZU360	P360	yellow	d150	pack. (100 pcs.)	10
40KZU400	P400	yellow	d150	pack. (100 pcs.)	10
40KZU500	P500	yellow	d150	pack. (100 pcs.)	10
40KZU600	P600	yellow	d150	pack. (100 pcs.)	10
40KZU800	P800	yellow	d150	pack. (100 pcs.)	10

• APP Classic

Abrasive disk d150, brown colored, 14+1 holes, Velcro fastened

APP Classic abrasive disk with an artificial corundum (aluminum oxide) grain on a very elastic base made from C and B latex paper, intended for mechanical grinding of hard and medium dusting polyester, acrylic, polyurethane, wooden, MDF and plastic surfaces using handheld electric and pneumatic grinders with a dust suction function.

› ADVANTAGES

- evenly distributed grain guarantees perfect finishing of the sanded surfaces
- the slightly open coating of brown, hard, dulling-resistant grain ensures excellent efficiency and durability
- the stearate Volume in the second adhesive layer prevents clogging during the entire product exploitation duration, extending its service life
- two layers of very strong adhesive (phenolic resin over resin) secure the grain against chipping
- product with universal applications, resulting in economical inventory maintenance

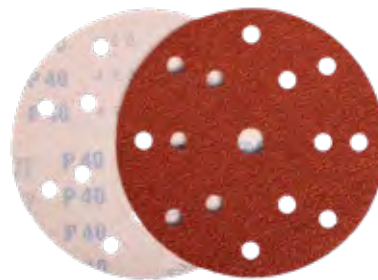

APP NO.	Description	Color	Size	Sales unit
40KBCM0040	P40	brown	d150	pack. (10 pcs.)
40KBCM0060	P60	brown	d150	pack. (10 pcs.)
40KBCM0080	P80	brown	d150	pack. (10 pcs.)
40KBCM0100	P100	brown	d150	pack. (10 pcs.)
40KBCM0120	P120	brown	d150	pack. (10 pcs.)
40KBCM0150	P150	brown	d150	pack. (10 pcs.)
40KBCM0180	P180	brown	d150	pack. (10 pcs.)
40KBCM0220	P220	brown	d150	pack. (10 pcs.)
40KBCM0240	P240	brown	d150	pack. (10 pcs.)
40KBCM0280	P280	brown	d150	pack. (10 pcs.)
40KBCM0320	P320	brown	d150	pack. (10 pcs.)
40KBCM0360	P360	brown	d150	pack. (10 pcs.)
40KBCM0400	P400	brown	d150	pack. (10 pcs.)
40KBCM0500	P500	brown	d150	pack. (10 pcs.)
40KBCM0600	P600	brown	d150	pack. (10 pcs.)
40KBCM0800	P800	brown	d150	pack. (10 pcs.)

APP NO.	Description	Color	Size	Sales unit
40KBC040	P40	brown	d150	pack. (50 pcs.)
40KBC060	P60	brown	d150	pack. (50 pcs.)
40KBC080	P80	brown	d150	pack. (50 pcs.)
40KBC100	P100	brown	d150	pack. (100 pcs.)
40KBC120	P120	brown	d150	pack. (100 pcs.)
40KBC150	P150	brown	d150	pack. (100 pcs.)
40KBC180	P180	brown	d150	pack. (100 pcs.)
40KBC220	P220	brown	d150	pack. (100 pcs.)
40KBC240	P240	brown	d150	pack. (100 pcs.)
40KBC280	P280	brown	d150	pack. (100 pcs.)
40KBC320	P320	brown	d150	pack. (100 pcs.)
40KBC360	P360	brown	d150	pack. (100 pcs.)
40KBC400	P400	brown	d150	pack. (100 pcs.)
40KBC500	P500	brown	d150	pack. (100 pcs.)
40KBC600	P600	brown	d150	pack. (100 pcs.)
40KBC800	P800	brown	d150	pack. (100 pcs.)

• APP R115 i APP RH70

Brown sandpaper in rolls, dimensions 115 mm x 25 m and 70 mm x 25 m

Sandpaper with an artificial corundum (aluminum oxide) grain on a base from very elastic, C and B latex paper, intended for mechanical and manual grinding of hard and medium dusting polyester, acrylic, polyurethane, wooden, MDF and plastic surfaces using handheld electrical and pneumatic grinders with a dust suction function.

▶ ADVANTAGES

- evenly distributed grain guarantees perfect finishing of the sanded surfaces
- the slightly open coating of brown, hard, dulling-resistant grain ensures excellent efficiency and durability
- stearate Volume in the second adhesive layer prevents clogging throughout the entire product exploitation time, extending its service life
- two layers of very strong adhesive (phenolic resin over resin) protects the grain against chipping
- product with universal applications, resulting in economical inventory maintenance

APP R115

Brown sandpaper in rolls, dimensions 115 mm x 25 m

APP NO.	Description	Color	Size	Col. Pack.
40R0040	P40	brown	115 mm x 25 m	5
40R0060	P60	brown	115 mm x 25 m	5
40R0080	P80	brown	115 mm x 25 m	5
40R0100	P100	brown	115 mm x 25 m	5
40R0120	P120	brown	115 mm x 25 m	5
40R0150	P150	brown	115 mm x 25 m	5
40R0180	P180	brown	115 mm x 25 m	5
40R0240	P240	brown	115 mm x 25 m	5
40R0280	P280	brown	115 mm x 25 m	5
40R0320	P320	brown	115 mm x 25 m	5
40R0400	P400	brown	115 mm x 25 m	5



APP RH70

Brown sandpaper in rolls, dimensions 70 mm x 25 m

APP NO.	Description	Color	Size	Col. Pack.
40RH040	P40	brown	70 mm x 25 m	8
40RH060	P60	brown	70 mm x 25 m	8
40RH080	P80	brown	70 mm x 25 m	8
40RH100	P100	brown	70 mm x 25 m	8
40RH120	P120	brown	70 mm x 25 m	8
40RH150	P150	brown	70 mm x 25 m	8
40RH180	P180	brown	70 mm x 25 m	8
40RH240	P240	brown	70 mm x 25 m	8
40RH320	P320	brown	70 mm x 25 m	8



• APP PS G

Sand paper on a sponge base in a roll, dimensions 115 mm x 25 m (200 sheets/sections)

Sandpaper with an artificial corundum (aluminum oxide) grain coated with a stearate compound on an elastic latex paper base applied to a soft PU sponge. Intended for manual grinding of medium hard and highly dusting polyester, acrylic and polyurethane surfaces. Used for dry grinding anywhere, where mechanical processing is not possible, on irregular surfaces, in difficult to reach areas, on profiles, edges, etc.

▶ ADVANTAGES

- very hard and even grain, resistant to dulling
- additional stearate layer (P150-P800) – guarantees very high resistance to clogging of spaces between the grains, ensuring high efficiency
- extended grinding time thanks to an optimal combination of abrasive grain in an open type coating with a layer protecting against clogging
- elastic and smooth latex paper base to optimize work on profiled and flat surfaces during finishing works
- incorporation of a PU sponge results in uniform pressure on the abrasive material and easy adjustment to rounded surface shapes
- features perforation that facilitates tearing off sheets in dimensions of 115 mm x 125 mm

APP NO.	Description	Color	Size
40RG150	P150	yellow	115 mm x 25 m
40RG180	P180	yellow	115 mm x 25 m
40RG240	P240	yellow	115 mm x 25 m
40RG320	P320	yellow	115 mm x 25 m
40RG400	P400	yellow	115 mm x 25 m
40RG500	P500	yellow	115 mm x 25 m
40RG600	P600	yellow	115 mm x 25 m
40RG800	P800	yellow	115 mm x 25 m



• NTools 722 SG

Ceramic, endless abrasive tapes, dimensions of 10 mm x 330 mm

Endless abrasive tapes with a ceramic coating on a base made from reinforced, elastic, technical polyester fabric. They are intended for rough grinding of stainless and acid-proof steel, tool and tempered steel, structural and carbon steel, and non-ferrous metals. They are available in 4 gradations: P40, P60, P80, P120 and sold in sets of 10 pcs. The tapes, together with the NTools PPT 139300N tape file, are ideally suited for grinding tight, difficult to reach areas such as: spherical surfaces, pipes, corners, etc.

➤ ADVANTAGES

- high tear resistance while maintaining the appropriate elasticity
- high efficiency with moderate temperature increase of the processed element
- strongly embedded abrasive material guarantees high efficiency at medium pressure
- suitability for dry and wet work



APP NO.	Description	Size	Sales unit
06TSC0040	P40	10 x 330 mm	pack. (10 pcs.)
06TSC0060	P60	10 x 330 mm	pack. (10 pcs.)
06TSC0080	P80	10 x 330 mm	pack. (10 pcs.)
06TSC0120	P120	10 x 330 mm	pack. (10 pcs.)



• APP FLEX

One-sided abrasive sponge, dimensions 140 mm x 115 mm x 6 mm

One-sided, thin and elastic abrasive sponges in sheets, intended for manual processing of filler putties, bases, top coat paints and lacquers, plastic materials, metal, wood and its derivatives. They are made from EVA* type foam bonded with an aluminum oxide and silicon carbide abrasive grain using very elastic synthetic resin.

➤ ADVANTAGES

- does not crack when folding
- ensures excellent quality of the sanded surface due to uniform pressure
- reaches areas difficult to access for sandpaper
- adapts to the shape and profile of irregular surfaces ensuring a uniform finish



* EVA type foam – a closed cell form manufactured as a ethylene and acetate copolymer etylenu i octanu winylu

APP NO.	Description	Final result	APPLICATION	Size	Sales unit
40Z200	MEDIUM	P150-P180	Do szlifowania przed nałożeniem szpachli oraz do jej kształtowania	sheet 140 x 115 x 6 mm	20 pcs.
40Z210	FINE	P240-P280	Do szlifowania przed nałożeniem podkładu lakierniczego, stępienia ostrych krawędzi	sheet 140 x 115 x 6 mm	20 pcs.
40Z220	SUPER FINE	P400-P600	Do szlifowania podkładu przed nałożeniem lakieru nawierzchniowego	sheet 140 x 115 x 6 mm	20 pcs.
40Z230	ULTRA FINE	P800-P1000	Do przygotowania powierzchnia pod szczególnie trudne Colory wielowarstwowe oraz do szlifowania lakierów bazowych podczas usuwania drobnych defektów	sheet 140 x 115 x 6 mm	20 pcs.

• APP WS 222 i APP WSR 222

Abrasive fabric in sheets, dimensions 150 mm x 230 mm, and 100 mm x 10 m rolls

APP WS/WSR 222 is an abrasive fabric with an open, three-dimensional web structure of non-woven, nylon fibers soaked with resin with a spray-on abrasive grain. The abrasive fabrics are an alternative to coated abrasive materials in difficult to reach places with complicated shapes. They are comfortable to use and allow to significantly speed up preparation works (surface matting). They are particularly effective when used in tandem with the APP PM 07 matting paste in transitional areas during surface preparation for shading. The abrasive fabric is used in the process of manual and mechanical surface grinding.

➤ ADVANTAGES

- open, three-dimensional fiber structure prevents clogging of the fabric, extending its service life
- guarantees uniform abrasion of the entire sanded surface
- high fabric elasticity allows to adapt to the processed shape and process difficult to reach areas
- does not alter the shape and texture of the processed surface
- enables dry and wet work

APP WS 222 / abrasive fabric in sheets

APP NO.	Description	Color	Size	Sales unit
06Z200	coarse grain	green	150 x 230 mm	pack. (10 pcs.)
06Z210	medium grain	red	150 x 230 mm	pack. (10 pcs.)
06Z220	fine grain	grey	150 x 230 mm	pack. (10 pcs.)
06Z230	micro-grain	gold	150 x 230 mm	pack. (10 pcs.)



APP WSR 222 / abrasive fabric in rolls

APP NO.	Description	Color	Size
06ZR200	coarse grain	green	100 mm x 10 m
06ZR210	medium grain	red	100 mm x 10 m
06ZR220	fine grain	grey	100 mm x 10 m
06ZR230	micro-grain	gold	100 mm x 10 m



• APP PM 07

Matting paste

APP PM-07 is a paste for matting surfaces during spray-painting works and SMART repairs. It is intended for preparing surfaces for spray-painting in blended and difficult to reach areas or on old pain coats. The compound removes grease and waxes, while also adding a matt finish to the processed surface.



▶ ADVANTAGES

- leaves a uniform, matt finish while partially retaining the old surface structure
- Matts while also degreasing and cleaning the surface
- perfectly prepares the surface prior to shading with the base and colorless lacquer
- for use with an abrasive fabric, sponge or cleaning cloth

APP NO.	Weight	Col. Pack.
081210	1 kg	8 pcs.

• APP F541

Fiber abrasive disks d125

Fiber abrasive disks with an artificial corundum (aluminum oxide) grain in a closed coating, bonded with synthetic resin (phenolic resin over resin) on a fiber base ensuring very high mechanical strength. They are intended for coarse and precise processing while grinding welding seams, removing burrs and rust on various materials such as: metal, stainless steel, wood, lacquer, fiberglass laminate. The incorporated abrasive material ensures long-term exploitation. The disk's maximum rotational speed is 80 m/s. The fiber abrasive disks are compatible with the APP Turbo support plate (APP NO. 150531 - 125mm).



APP NO.	Option	Color	Size	Sales unit
40XY016	P16	brown	d125 x 22 mm	pack. (25 pcs.)
40XY024	P24	brown	d125 x 22 mm	pack. (25 pcs.)
40XY036	P36	brown	d125 x 22 mm	pack. (25 pcs.)
40XY040	P40	brown	d125 x 22 mm	pack. (25 pcs.)
40XY060	P60	brown	d125 x 22 mm	pack. (25 pcs.)
40XY080	P80	brown	d125 x 22 mm	pack. (25 pcs.)
40XY100	P100	brown	d125 x 22 mm	pack. (25 pcs.)
40XY120	P120	brown	d125 x 22 mm	pack. (25 pcs.)

• APP Turbo

Fiber disk support plate d125 with an M14 nut

Support plate for mounting fiber disks, intended for coarse and finish grinding. The TURBO support plate features ribbing that reduces the temperature generated while grinding, which has a significant impact on the durability of abrasive materials. It comes equipped with an M14 mounting nut. The maximum rotational speed is 80 m/s.

▶ ADVANTAGES

- reduces the temperature generated while grinding
- lower risk of overheating the sanded element
- longer service life of the fiber abrasive disk

APP NO.	Size
150531	d125



• System NTools Fast LOCK

The NTools Fast LOCK System is an excellent solution wherever there is a need to process small elements or difficult to reach areas. The specially designed grip enables very quick tool replacement within a time below 5 seconds, all thanks to the "FAST LOCK" technology.vvv

➤ ADVANTAGES

- a single lock system for many abrasive tools, ensuring their quick replacement
- unified thread for quick mounting
- ability to work in difficult to reach areas
- quick processing of small elements
- system compatible with 3M Rolock and Norton SpeedLok TR systems

NTools Fast LOCK KS ➤ Abrasive disk d50, blue, with TR connector

Abrasive disks with a zircon grain coating on a canvas base, intended for processing most metals. Grain gradation range from P40 to P120. Incorporating a zircon coating allows to achieve much higher aggressiveness and efficiency compared to traditional artificial corundum grain. The tool is intended for grinding, removal of burrs, finishing flat and irregular surfaces. Maximum working speed: 20000 RPM.

APP NO.	Description	Color	Size	Sales unit
06FLK0040	P40	blue	d50	pack. (10 pcs.)
06FLK0060	P60	blue	d50	pack. (10 pcs.)
06FLK0080	P80	blue	d50	pack. (10 pcs.)
06FLK0120	P120	blue	d50	pack. (10 pcs.)
06FLK0040B	P40	blue	d50	pack. (100 pcs.)
06FLK0060B	P60	blue	d50	pack. (100 pcs.)
06FLK0080B	P80	blue	d50	pack. (100 pcs.)
06FLK0120B	P120	blue	d50	pack. (100 pcs.)

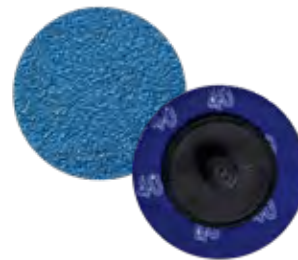

NTools Fast LOCK DS ➤ Abrasive disk d50, black, from hard nonwoven fabric, with a TR connector

Hard nonwoven fabric impregnated with resin, with an abrasive material in the form of a disk, intended for removing old bituminous masses and sealants, paint and base layers, fillers, rust, scale, and chippings created during welding. Aggressive and elastic, does not clog during work. Maximum working speed: 20000 RPM.

APP NO.	Color	Size	Sales unit
06FLD0002	black	d50	pack. (5 pcs.)
06FLD0002B	black	d50	pack. (25 pcs.)



NTools Fast LOCK WS ➤ Abrasive nonwoven fabric d50 in three granularities, with a TR connector

Abrasive nonwoven with an open, three-dimensional structure that prevents clogging, made from nylon fibers, coated with a spray-on resin with abrasive grains. Available in three granularity variants: fine grain – blue colored, medium grain – red colored, and coarse grain – brown colored. The nonwoven allows to significantly speed up finishing works involving grinding, removal of defects, and removal of corrosion. Maximum working speed: 20000RPM.

APP NO.	Description	Color	Size	Sales unit
06FLW0001	fine grain	blue	d50	pack. (5 pcs.)
06FLW0002	medium grain	red	d50	pack. (5 pcs.)
06FLW0003	coarse grain	brown	d50	pack. (5 pcs.)
06FLW0001B	fine grain	blue	d50	pack. (50 pcs.)
06FLW0002B	medium grain	red	d50	pack. (50 pcs.)
06FLW0003B	coarse grain	brown	d50	pack. (50 pcs.)



NTools Fast LOCK TM ➤ Mounting disk d50 with a TR connector and 6 mm pin

Elastic support disk with a 50 mm diameter, with a fast lock system for the abrasive material. It features a mounting pin with a diameter of 1/4" (6 mm) intended for clamp holders of high-speed rotary grinders, e.g. NTools PSK. Maximum rotational speed: 30 000 RPM.

APP NO.	Description	Weight / Volume	Sales unit
06FLU0002	6 mm	d50	pack. (2 pcs.)
06FLU0002B	6 mm	d50	pack. (25 pcs.)



• APP DS

Abrasive disk d100 and d150, black, for mounting pin

Hard nonwoven fabric impregnated with synthetic resin with an abrasive material, in the form of a 13 mm thick disk for mechanical removal of paint and base layers, sealing masses, chassis protective coatings, and rust. It is elastic and does not clog during work. Using the APP TM DS mounting grips, the disks can be mounted to grinders and drills. Maximum rotational speed 2500 RPM.

APP NO.	Color	Size	Col. Pack.
06X100	black	100 x 13 x 13 mm	10 pcs.
06X150	black	150 x 13 x 13 mm	10 pcs.



• APP DS R

Abrasive disk d115, pressed, red, for mounting pin

Elastic disk made from a hard nonwoven fabric, impregnated with synthetic resin, with an abrasive material, filled with a red foam mass, also containing abrasive grains. It is intended for mechanical removal of sealing masses, chassis protective coatings, paint and base layers, as well as rust. Excellent for removing discoloration and deposits from stainless steel. Cleans the surface thoroughly and quickly without interfering deep into the surface. Using the APP TM DS mounting grip, the disks can be mounted on grinders and drills. Maximum rotational speed: 4500 RPM.



➤ ADVANTAGES

- enhanced efficiency thanks to incorporation of a filler with abrasive grain
- increased mechanical strength compared to classic disks
- very high resistance to clogging

APP NO.	Color	Size
06XC115	red	115 x 13 x 13 mm

• APP TM DS

Mounting pin for abrasive disks d13, with a 6 mm fastening

Pin for mounting abrasive disks to straight grinders or drills. The set includes a mounting pin, two pads and a nut.

APP NO.	Description
06X900	fastening 6 mm



• APP DSK

Abrasive disk d115 and d 125, black, for angle grinders

Hard nonwoven fabric impregnated with synthetic resin, with an abrasive material for mechanical removal of paint and base layers, sealing masses, chassis protective coatings, rust, scale, and chippings created during welding. Does not clog during work and does not interfere deep into the processed surface. The open structure and low working temperature prevent clogging and significantly extend the abrasive disk's service life. Optimal working speed 4000-5000 RPM.

APP NO.	Color	Size	Col. Pack.
06XK115	black	115 x 22 mm	10 pcs.
06XK125	black	125 x 22 mm	10 pcs.



• NTools LL 125

Steel grinding flap wheel

The grinding flap wheel is built from flaps (blades) from an abrasive canvas with corundum grains, applied in a fanlike configuration on a fiberglass base. Thanks to this flap configuration, the grinding wheel achieves high working elasticity and significantly increased efficiency compared to other tools. The flap configuration forces cooling during grinding, ensuring a cool grind. The grinding wheels feature very good abrasive properties

➤ Application, type of processing:

- processing of welds and welding seams
- removal of burrs and rust from steel and non-ferrous metals
- cleaning of molds
- edge processing
- grinding of sides and corners
- grinding of surfaces

APP NO.	Description	Size	Col. Pack.
06XLM40	P40	125 x 22 mm	10 pcs.
06XLM60	P60	125 x 22 mm	10 pcs.
06XLM80	P80	125 x 22 mm	10 pcs.
06XLM120	P120	125 x 22 mm	10 pcs.



• APP SDC

Disk for cutting stainless and regular steel

The d115 and d125 stainless and carbon steel cutting disks with thicknesses of 1,0; 1,2 and 1,6, FEPA 41 shape (flat) do not contain iron, sulfur or chlorine. They are intended to cut stainless steel using small-sized, handheld angle grinders with rotational speeds of up to 80 m/s. The disk features an artificial corundum grain coating and fillers that prevent clogging of the disk and coloring of steel, even during extended use.

APP NO.	Size	Col. Pack.
06YA00	115 x 1,0 x 22,23 mm	25 pcs.
06YA03	115 x 1,6 x 22,23 mm	25 pcs.
06YA10	125 x 1,0 x 22,23 mm	25 pcs.
06YA12	125 x 1,2 x 22,23 mm	25 pcs.
06YA13	125 x 1,6 x 22,23 mm	25 pcs.



• APP SDCS

Steel cutting and grinding disk

Cutting disks d115 and d125 in the FEPA 42 shape (lowered center) with a thickness of 2,5 mm ensure a wide range of applications during car bodywork repairs. They are intended for cutting steel using small-sized, handheld angle grinders with rotational speeds up to 80 m/s.

APP NO.	Size	Col. Pack.
06YA40	115 x 2,5 x 22,23 mm	50 pcs.
06YA50	125 x 2,5 x 22,23 mm	50 pcs.



• APP SDSS

Steel grinding disks

Steel grinding disks d115 and d125 in the FEPA 27 shape (lowered center) with a thickness of 6,4 mm enable safe and effective grinding of welds, processing of surfaces and grading. The disks are intended for work on steel using small-sized, handheld angle grinders with rotational speeds up to 80 m/s.

APP NO.	Size	Col. Pack.
06YA20	115 x 6,4 x 22,23 mm	10 pcs.
06YA30	125 x 6,4 x 22,23 mm	10 pcs.



• NTools Wire Brush 75C, 75P i 100P

Wire face and flat d75 brushes, and flat 100 brushes

A wire brush with a hexagonal pin for mounting in a drill or drill-driver. The reinforced structure of the body enables efficient cleaning of steel, wood and plastic materials. The hexagonal pin prevents "slipping" in the mounting grip.

› Application, processing type:

- removal of rust
- removal of burrs
- removal of old paint coats
- cleaning of welds

APP NO.	Model	Description	Option	Size	Col. Pack.
250150	NTools Wire Brush 75P	hex pin 1/4"	hex pin	d 75 mm	20 pcs.
250151	NTools Wire Brush 100P	hex pin 1/4"	flat	d 100 mm	10 pcs.
250155	NTools Wire Brush 75C	hex pin 1/4"	face	d 75 mm	10 pcs.

• Product in use

01

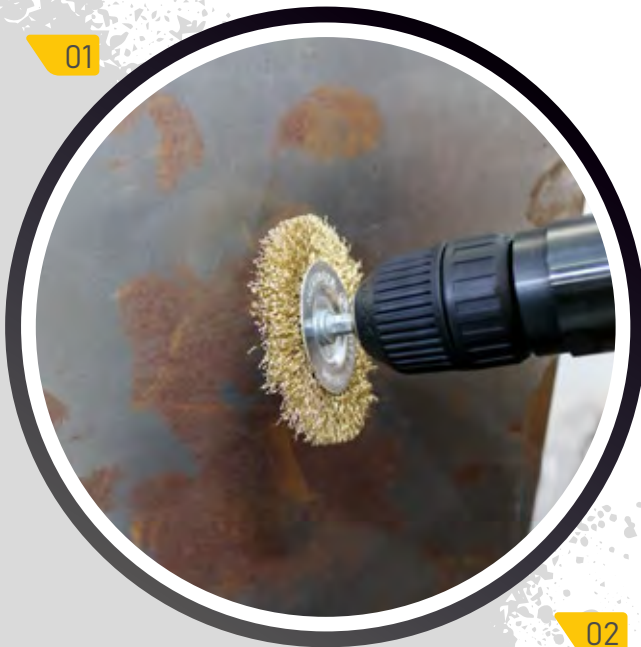

02



APP NO. 250150



APP NO. 250151



APP NO. 250155

SPRAY-PAINTING



Masking systems

21-232 SPRAY-PAINTING

- 21-28 Putties and fillers
- 29-36 Base and primers
- 37-46 Top coats
- 47-56 Modular color selection system
- 57-62 Thinners, removers and additives
- 63-67 Repair of plastics
- 69-76 Adhesives and sealants
- 77-84 Car body protection and soundproofing
- 85-96 Abrasives
- 97-106 • Masking systems**
- 107-118 Polishing
- 119-126 OHS
- 127-132 Fabric filters and spray-painting booth accessories
- 133-154 Workshop auxiliary equipment
- 155-170 Various spray-painting products
- 171-178 Spray guns and extruders
- 179-186 Pneumatic grinders
- 187-192 Electric grinders, heat guns and lamps
- 193-198 Work disks
- 199-204 Dust extraction
- 205-208 Radiators
- 209-218 Pneumatics
- 219-222 Spray gun regenerators and washers
- 223-232 Technical sprays

• APP Red Tape

Masking tape

APP Red Tape is the highest quality, self-adhesive painting masking tape on an impregnated, slightly corrugated, red paper medium with natural rubber based adhesive. It ensures excellent adhesion to the masked surface as well as simple and clean removal.



› ADVANTAGES

- excellent adhesion to the masked surface
- does not leave glue residue when removing
- UV resistant – for interior and exterior use
- resistant to moisture – can be used with water-dilutable as well as organic (conventional) paints and lacquers
- elasticized medium enables masking of very complex shapes
- resistant to temperatures up to +110°C



APP NO.	Description	Color	Size	Col. Pack.
070251	110°C	waterproof	18 mm	48 pcs.
070252	110°C	waterproof	24 mm	36 pcs.
070253	110°C	waterproof	30 mm	30 pcs.
070254	110°C	waterproof	36 mm	24 pcs.
070255	110°C	waterproof	48 mm	18 pcs.

• APP Expert 110

Masking tape

APP Expert 110 is a self-adhesive, brown, painting masking tape on an impregnated slightly corrugated, paper medium with a natural rubber based adhesive. It is intended for masking surfaces during spray-painting works. It ensures excellent adhesion to the masked surface as well as simple and clean removal.



› ADVANTAGES

- does not leave glue residue when removing
- resistant to paints, bases and primers containing organic thinners, as well as water-dilutable paints used in spray-painting
- elasticized medium enables masking of very complex shapes
- resistant to temperatures up to +110°C



APP NO.	Description	Color	Size	Col. Pack.
070206	110°C	brown	18 mm	48 pcs.
070207	110°C	brown	24 mm	36 pcs.
070208	110°C	brown	30 mm	30 pcs.
070209	110°C	brown	36 mm	24 pcs.
070210	110°C	brown	48 mm	18 pcs.

• APP Expert 80

Masking tape

APP Expert 80 is a self-adhesive, yellow, painting masking tape on an impregnated slightly corrugated, paper medium with a natural rubber based adhesive. It is intended for masking surfaces during spray-painting works. It ensures excellent adhesion to the masked surface as well as simple and clean removal.



› ADVANTAGES

- does not leave glue residue when removing
- resistant to paints, bases and primers containing organic thinners used in spray-painting
- elasticized medium enables masking of very complex shapes
- resistant to temperatures up to +80°C



APP NO.	Description	Color	Size	Col. Pack.
070201	80°C	yellow	18 mm	48 pcs.
070202	80°C	yellow	24 mm	36 pcs.
070203	80°C	yellow	30 mm	30 pcs.
070204	80°C	yellow	36 mm	24 pcs.
070205	80°C	yellow	48 mm	18 pcs.

• APP Plus 100

Masking tape

APP Plus 100 brown, self-adhesive painting masking tape on an impregnated slightly corrugated, paper medium with a natural rubber based adhesive. It is intended for masking surfaces during spray-painting works. It ensures excellent adhesion to the masked surface as well as simple and clean removal.

› ADVANTAGES

- does not leave glue residue when removing
- resistant to paints, bases and primers containing organic thinners and water-dilutable lacquers used in spray-painting
- increased mechanical strength – no tendency to tear during masking and removal
- resistant to temperatures up to +100°C

APP NO.	Description	Color	Size	Col. Pack.
070106	100°C	brown	18 mm	48 pcs.
070107	100°C	brown	24 mm	36 pcs.
070108	100°C	brown	30 mm	30 pcs.
070109	100°C	brown	36 mm	24 pcs.
070110	100°C	brown	48 mm	18 pcs.



• APP Plus 80

Masking tape

APP Plus 80 self-adhesive, yellow, painting masking tape on an impregnated slightly corrugated, paper medium with a natural rubber based adhesive. It is intended for masking surfaces during spray-painting works. It ensures excellent adhesion to the masked surface as well as simple and clean removal.

› ADVANTAGES

- does not leave glue residue when removing
- resistant to paints, bases and primers containing organic thinners used in spray-painting
- increased mechanical strength – no tendency to tear during masking and removal
- resistant to temperatures up to +80°C

APP NO.	Description	Color	Size	Col. Pack.
070101	80°C	yellow	18 mm	48 pcs.
070102	80°C	yellow	24 mm	36 pcs.
070103	80°C	yellow	30 mm	30 pcs.
070104	80°C	yellow	36 mm	24 pcs.
070105	80°C	yellow	48 mm	18 pcs.



• APP Standard 60

Masking tape

APP Standard 60 is a self-adhesive painting masking tape on an impregnated slightly corrugated, paper medium with a natural rubber based adhesive. It is intended for masking surfaces during spray-painting works. It ensures excellent adhesion to the masked surface as well as simple and clean removal.

› ADVANTAGES

- does not leave glue residue when removing
- resistant to paints, bases and primers containing organic thinners used in spray-painting
- increased mechanical strength – no tendency to tear during masking and removal
- resistant to temperatures up to +60°C

APP NO.	Description	Color	Weight / Volume	Col. Pack.
070051	60°C	yellow	18 mm	48 pcs.
070052	60°C	yellow	24 mm	36 pcs.
070053	60°C	yellow	30 mm	30 pcs.
070054	60°C	yellow	36 mm	24 pcs.
070055	60°C	yellow	48 mm	18 pcs.



• APP TOM

Masking and deflecting tape

APP TOM is a self-adhesive tape intended for masking and simultaneously deflecting rubber car seals. It is intended for masking bodywork elements such as seals of windows, tilting roofs, lamps, etc.

➤ ADVANTAGES

- allows for lacquering the element under the seal without disassembly and without staining
- resistant to paints, bases and primers containing organic thinners used in spray-painting
- tape perforation facilitates separation during masking
- temperature resistant

APP NO.	Description	Color	Size	Col. Pack.
070301	strip 19 mm	yellow	45 mm x 10 m	36 pcs.
070302	strip 15 mm	yellow	45 mm x 10 m	36 pcs.
070303	strip 10 mm	yellow	45 mm x 10 m	36 pcs.



• APP TOM 2

Masking and deflecting tape with divided strips 9/11 mm

APP TOM 2 is a self-adhesive tape with divided strips 9/11 mm intended for masking and simultaneous deflection of rubber car seals. It is used to mask the seals of windows, tilting roofs, doors, etc.

➤ ADVANTAGES

- resistant to paints, bases and primers containing organic thinners used in spray-painting
- allows for lacquering the element under the seal without disassembly and without staining
- divided strips allow to choose the tape width: 9 mm or 11 mm
- tape perforation facilitates separation during masking
- resistant to the effects of high temperatures +120°C
- with strip without adhesive facilitates tape removal after finishing work

APP NO.	Description	Color	Size
070305	divided strip 9/11 mm	yellow	50 mm x 10 m



• APP TR

Thin-line masking tape

APP TR is a thin-line masking tape made from flexible PVC foil, intended for color separation.

➤ ADVANTAGES

- leaves sharp contours of applied lacquer
- can be applied on low radius curvatures without cockling and tearing
- leaves no glue or marks on fresh lacquer coats
- excellent elasticity and adhesion to a wide range of surfaces

APP NO.	Color	Size	Col. Pack.
070369	blue	3 mm x 33 m	10 pcs.
070370	blue	6 mm x 33 m	10 pcs.
070371	blue	9 mm x 33 m	10 pcs.



• APP S 50

Protective tape

APP S-50 is a waterproof, self-adhesive tape for protecting surfaces while grinding, cutting and other works involved in bodywork repair and refinishing. Thanks to the inclusion of reinforced, polyurethane coated fabric and a natural rubber-based adhesive, the tape provides reliable protection and guarantees the safety of the secured surface.

➤ ADVANTAGES

- internal structure enables easy, transverse tearing off of the required piece of tape without the need for tools
- very good adhesion to plastic surfaces such as polycarbonate (headlights) as well as glass, lacquered surfaces and metal
- resistant to UV radiation
- for both interior and exterior applications

APP NO.	Color	Size
070250	silver	50 mm x 50 m



• APP Pack Tape

Packing tape

The APP Pack Tape is a high quality packing tape on a medium of durable PP (BOPP) film and a natural rubber-based adhesive (solvent). It is intended for manually sealing cartons and other packages made from various types of materials. Very good adhesion to coarse surfaces.

➤ ADVANTAGES

- resistant to moisture
- high mechanical strength
- effective even in low temperatures
- excellent elasticity and maximum adhesion to a wide range of surfaces
- heightened temperature resistance, from -30°C to +60°C

APP NO.	Color	Size
070040	transparent	48 mm x 60 m
070041	brown	48 mm x 60 m



• APP Wide Tape

Self-adhesive foam tape

APP Wide Tape is a multipurpose, self-adhesive foam tape intended for covering gaps between doors, engine and trunk covers and their recesses in the vehicle's bodywork. Simultaneously, it provides soft and smooth transitions between the lacquer applied to the edges of the recesses and embossed areas on the bodywork.

➤ ADVANTAGES

- asymmetrically applied adhesive layer – covers a larger gap compared to an adhesive placed in the center
- elliptical shape – covers larger gaps compared to round shaped tapes
- notch (breaking) in the center – facilitates contact inside gaps
- resistant to the effects of high temperatures, up to +95°C
- effectively prevents penetration of lacquer inside the painted vehicle
- ensures smooth transitions between the freshly painted surface and the masked surface
- does not leave glue residue when removing after painting
- resistant to paints, bases and primers containing organic thinners used in spray-painting

APP NO.	Color	Size
070358	white	20 mm x 50 m



• APP No Edge Tape

Self-adhesive foam tape

APP No Edge Tape is an edgeless, self-adhesive foam tape intended for performing soft and smooth transitions of the applied lacquer on edges and embossing lines. It is intended for covering fuel inlets, plugs, edges of bumpers, wheel arches, fenders, and doors, e.g. the gap between the front fender and the door.

➤ ADVANTAGES

- effectively prevents penetration of lacquer inside the painted vehicle
- ensures smooth transitions between the freshly painted surface and the masked surface
- does not leave glue residue when removing after painting
- resistant to paints, bases and primers containing organic thinners used in spray-painting
- resistant to the effects of high temperatures, up to +95°C
- high elasticity – easily applied on arches, e.g. in fuel inlet recesses

APP NO.	Color	Size
070355	white	15 mm x 25 m



• APP 3D Tape

Self-adhesive foam tape

APP 3D Tape is a soft, elastic, self-adhesive foam tape for protecting gaps, e.g. between doors and the car body.

➤ ADVANTAGES

- effectively prevents penetration of lacquer inside the painted vehicle
- ensures smooth transitions between the freshly painted surface and the masked surface
- does not leave glue residue when removing
- resistant to paints, bases and primers containing organic thinners used in spray-painting
- temperature resistant

APP NO.	Color	Size
070350	white	13 mm x 50 m
070351	white	13 mm x 20 m



• APP P Mask Premium i APP P Mask Standard Masking paper

APP P Mask Premium is paper with one smoothed side and a surface density of 45 g/m², manufactured without the addition of wastepaper. Designed and manufactured as a specialized masking (covering) paper for the needs of refinishing car spray-painting and industrial spray-painting.

➤ ADVANTAGES

- non-dusting
- features a non-porous structure
- flexible – adjusts well to the car body shape
- maximum time to permeation of the cover by the applied lacquer
- shrink film packaging secures the paper against moisture and mechanical damage, and is used exclusively for the APP P Mask Premium

APP P Mask Standard is the same masking paper, but is not packaged in the marked shrink film protecting against mechanical damage and moisture.



P Mask Premium

P Mask Premium / Masking paper

APP NO.	Size	Sales unit
070410	30 cm x 300 m	1 pcs.
070410D	30 cm x 300 m	zestaw 2 pcs.
070420	60 cm x 300 m	1 pcs.
070420D	60 cm x 300 m	zestaw 2 pcs.
070430	90 cm x 300 m	1 pcs.
070430D	90 cm x 300 m	zestaw 2 pcs.
070440	120 cm x 300 m	1 pcs.
070450	150 cm x 300 m	1 pcs.



P Mask Standard

P Mask Standard / Masking paper

APP NO.	Size	Sales unit
070411	30 cm x 280 m	1 pcs.
070411D	30 cm x 280 m	zestaw 2 pcs.
070421	60 cm x 280 m	1 pcs.
070421D	60 cm x 280 m	zestaw 2 pcs.
070431	90 cm x 280 m	1 pcs.
070431D	90 cm x 280 m	zestaw 2 pcs.

• APP P Mask PE Coated masking paper

APP P Mask PE white car body masking paper, smoothed on one side and coated with PE film. It is intended for use wherever there are issues with permeation of coverings from pure cellulose by all types of lacquers, including water-dilutable ones.

➤ ADVANTAGES

- non-dusting
- time-saving – does not require double masking with paper and film in places where permeation of the applied lacquer is suspected
- complete protection against permeation of the applied lacquer
- CE certified for contact with food

APP NO.	Size
070451	30 cm x 200 m
070452	60 cm x 200 m



• APP F Cut Masking film cutter

APP F Cut is a cutter for the APP F Mask and APP FE Mask masking films. It enables quick and smooth-edged cutting of the required length of film, and precise removal of excess cover fragments from the surface of the element being repaired.

➤ ADVANTAGES

- simple and ergonomic structure
- optimal blade mounting angle
- safe and flexible cutting edge guide

APP NO.	Sales unit
170199	1 pcs.
170200	pack. 10 pcs.



• APP F Mask i APP FE Mask Spray-painting masking film

APP F-Mask is an electrostatic HDPE (High Density PE) spray-painting masking film, activated on one side, intended for covering undamaged parts of the car body and windshields during lacquering repairs. The activated film surface is resistant to peeling of the sprayed on primer, base and colorless lacquer

➤ ADVANTAGES

- for work with conventional and water-dilutable lacquers
- adapts very well to the car body shape
- enables quick coverage of vehicles right out of the cardboard packaging or film rack, by just one person
- limits the amount of masking tape used
- resistant to moisture and temperatures up to +120°C



F Mask

zobacz film



F Mask

APP NO.	Description	Option	Size
070501	thickness 10 micr.	carton	4 x 150 m
070504	thickness 10 micr.	carton	4,5 m x 134 m
070510	thickness 10 micr.	carton	4 x 300 m

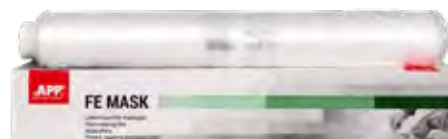

FE Mask

FE Mask

APP NO.	Description	Option	Size	Sales unit
070520	thickness 7 micr.	carton	4 m x 150 m	1 pcs.
070521	thickness 7 micr.	carton	4 m x 300 m	1 pcs.
070522	thickness 7 micr.	carton	5,8 m x 100 m	1 pcs.
070520D	thickness 7 micr.	carton	5,8 x 100 m + 4 x 150 m	set 2 pcs.
070521D	thickness 7 micr.	carton	5,8 x 100 m + 4 x 300 m	set 2 pcs.

• APP F HD i APP F LD Protective film 6 µm and 4µm

The films feature increased resistance to tearing, stretching and breaking. They are intended for protection against bodywork painting and renovation contamination, at workshops, offices, apartments, factory halls, and on various types of items, equipment, cars and furniture. APP F HD is a thick, universal high density polyurethane (HDPE) film with a 4µm thickness and four size variants: 4 x 5 m, 4 x 6 m, 4 x 7 m, 4 x 10 m.

➤ ADVANTAGES

- increased mechanical strength
- universal application
- can be unfolded by just one user



F HD - 6 µm

F HD / protective film 6 µm

APP NO.	Size	Sales unit
070703	4 x 5 m	pack. 40 pcs.

F LD / protective film 4 µm

APP NO.	Size	Sales unit
070704	4 x 5 m	pack. 50 pcs.
070705	4 x 6 m	pack. 40 pcs.
070706	4 x 7 m	pack. 30 pcs.
070707	4 x 10 m	pack. 25 pcs.



F LD - 4 µm

• APP FO S Stretch protective film roll

Steering wheel cover bands are effective protection against contamination with grease during vehicle repairs or servicing. They are intended for use in paint shops and repair workshops. The rotating roll with a grip facilitates storage and foil application onto the protected items.

APP NO.	Size
070810	10 cm x 150 m



• APP FO SU Handle for Stretch protective film rolls

APP NO.	Description
070811	handle for Stretch protective film rolls



• APP WP 4

Wheel covers

Protective wheel covers made from polypropylene, with a surface density of 40 g/m². The covers protect against accidental staining during car body painting.

▶ ADVANTAGES

- universal cover size allows to protect the wheels of any passenger car
- easy and quick application

APP NO.	Color	Sales unit
070813	white	pack. 4 pcs.

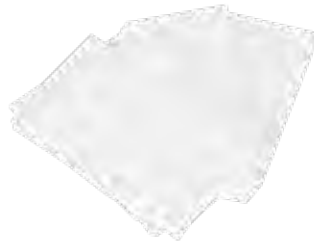

• APP Car Seat Cover

Multiple use protective car seat cover

The Protective APP Car Seat Cover is made from a high durability nylon fabric coated with a waterproof layer of PU. The cover protects the seat against staining and damage during car repairs and technical servicing, or during transport. It is characterized by a high resistance to water, grease and oils, effectively protecting the seat against all contaminants. The material is highly resistant to tearing and is flame retardant. It does not rigidify and crack in low temperatures.

APP NO.	Size
070817	universal



• APP Car Body Cover

Car body cover

Protective APP Car Body Covers made from modern, high-grade PEVA (polyethylene and vinyl polymers). They are fully resistant to water and UV radiation. Intended for both interior and exterior use. Recommended for use in highly dusty conditions. The product's use protects against adverse weather effects, rain, snow, frost or UV radiation. The cover also protects against animal droppings, tree resin and plant pollen. The material of the covers prevents accumulation of moisture, does not become rigid in the cold, is waterproof, does not scratch bodywork paint, and is breathable. The covers also feature ribbing in the front and back, which ensures proper adherence to the car body. The cover is very light and packaged in a handy bag.

Dimensions: size XL (533 x 178 x 119 cm), size XXL (572 x 203 x 121 cm). Silver color.

APP NO.	Option	Size	Col. Pack.
070815	XL	533 x 178 x 119 cm	6 pcs.
070816	XXL	572 x 203 x 121 cm	6 pcs.



• APP F PRO Black i APP F PRO

Protective tape, black and transparent

APP F PRO Black and APP F PRO are self-adhesive, protective films used to secure window strips, fragments of bumpers, side sills, etc. and in case of transparent film, to protect lacquered surfaces against: sanding, chipped stones and gravel, and scratches. The protective paper layer enables recreation of decorative protective elements with original, factory shapes, typical for various vehicle models. Broadly used in original assemblies of many car brands, e.g. Mercedes, Nissan, Peugeot, etc. The tape also finds its applications in the audio/video, home appliance, and other industries.

▶ ADVANTAGES

- easy to use, can be applied on dry or wet surfaces
- resistant to changing weather conditions
- enables cutting out any shape
- excellent adhesion to a wide range of surfaces
- deep black and matt ensure high aesthetic values of the protective layer for APP F PRO Black
- high gloss and excellent transparency ensure high aesthetic values of the protective layer of APP F PRO

APP NO.	Color	Size
070400	black	150 mm x 5 m
070390	transparent	100 mm x 2,5 m

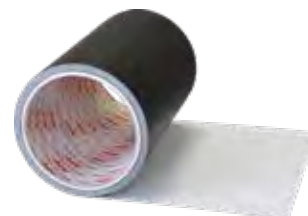

F PRO Black



F PRO

• APP Emblem Tape

Emblem tape

The APP Emblem Tape is a universal, transparent acrylic tape that enables application of letters, emblems and logos onto the surface of the bodywork. It is resistant to weather effects. The incorporated acrylic adhesive guarantees high resistance to shear stress, durability of adhesion, and resistance to washing at a car wash.

➤ ADVANTAGES

- transparent and colorless
- very good resistance to UV radiation
- very good resistance to moisture
- thermal resistance from -30°C to +90° C

APP NO.	Option	Size	Sales unit
040920	sheet	100 x 200 mm	set (5 pcs.)



• APP TD Super

Two-sided adhesive tape

The blue, two-sided, foam adhesive tape is intended for mounting side moldings and decorative elements, and for permanently joining elements made from different materials. It is characterized by high mechanical strength, resistance to adverse weather conditions, and variable temperatures.

➤ ADVANTAGES

- very good UV radiation resistance
- features soundproofing and sealing properties
- compensates for unevenness of joined surfaces
- compensates for vibrations
- thermal resistance from -20°C to +120°C

APP NO.	Color	Weight / Volume	Col. Pack.
040810	blue	6 mm x 5 m	132 pcs.
040811	blue	9 mm x 5 m	96 pcs.
040812	blue	12 mm x 5 m	80 pcs.
040813	blue	19 mm x 5 m	48 pcs.
040814	blue	25 mm x 5 m	36 pcs.
040820	blue	6 mm x 10 m	160 pcs.
040821	blue	9 mm x 10 m	116 pcs.
040822	blue	12 mm x 10 m	90 pcs.
040823	blue	19 mm x 10 m	60 pcs.
040824	blue	25 mm x 10 m	44 pcs.



• APP Acryl Tape

Acrylic two-sided adhesive tape

APP Acryl Tape is a two-sided, acrylic adhesive tape for interior and exterior use, characterized by increased mechanical strength. It is intended for permanently mounting side moldings and decorative elements, and for use as a sealing material. It allows to substitute welding, liquid bonding agents and other permanent joining measures.

➤ ADVANTAGES

- adhesion to many types of surfaces
- good resistance to UV radiation
- very good moisture resistance
- thermal resistance from -30°C to +120°C

APP NO.	Color	Size	Col. Pack.
040916	red	6 mm x 5 m	14 pcs.
040910	red	9 mm x 5 m	14 pcs.
040911	red	12 mm x 5 m	14 pcs.
040912	red	19 mm x 5 m	14 pcs.
040917	red	6 mm x 10 m	14 pcs.
040913	red	9 mm x 10 m	14 pcs.
040914	red	12 mm x 10 m	14 pcs.
040915	red	19 mm x 10 m	14 pcs.



• APP TM 10

Transparent, two-sided mounting tape

A thin, transparent, two-sided adhesive mounting tape with high adhesion strength. Intended for interior and exterior applications. Resistant to UV radiation, moisture and adverse weather conditions.

➤ ADVANTAGES

- adhesion to many types of surfaces
- very good resistance to UV radiation
- very good moisture resistance
- thermal resistance from -30°C to +100°C

APP NO.	Color	Size
040904	transparent	12 mm x 10 m



• APP TOFIK

Two-sided adhesive tape removal disk with adapter

APP TOFIK is a hard rubber disk for the mechanical removal of adhesive residue, two-sided tapes, stickers and decorative strips from the car body. While removing adhesives, the disk does not damage the lacquer coating. Mounted to grinders and drills using an adapter.

> ADVANTAGES

- no tendency to get stuck
- does not require specialized tools
- multiple use product

APP NO.	Color
150407	brown



• APP RO 400

Two-sided adhesive tape removal disk

APP RO 400 is a hard rubber disk for the mechanical removal of adhesive residue, two-sided tapes, stickers and decorative strips from the car body. While removing adhesives, the disk does not damage the lacquer coating. Mounted to grinders and drills using an adapter.

> ADVANTAGES

- multiple use product
- does not require specialized tools

APP NO.	Color
150404	brown



• APP RO 400 A

Adhesive removal disk adapter

APP RO 400 A is a connector that enables mounting of APP adhesive removal disks to grinders and drills.

APP NO.	Description
150406	adapter



SPRAY-PAINTING

1



Polishing

21-232 SPRAY-PAINTING

- 21-28 Putties and fillers
- 29-36 Base and primers
- 37-46 Top coats
- 47-56 Modular color selection system
- 57-62 Thinners, removers and additives
- 63-67 Repair of plastics
- 69-76 Adhesives and sealants
- 77-84 Car body protection and soundproofing
- 85-96 Abrasives
- 97-106 Masking systems
- 107-118 • Polishing**
- 119-126 OHS
- 127-132 Fabric filters and spray-painting booth accessories
- 133-154 Workshop auxiliary equipment
- 155-170 Various spray-painting products
- 171-178 Spray guns and extruders
- 179-186 Pneumatic grinders
- 187-192 Electric grinders, heat guns and lamps
- 193-198 Work disks
- 199-204 Dust extraction
- 205-208 Radiators
- 209-218 Pneumatics
- 219-222 Spray gun regenerators and washers
- 223-232 Technical sprays

• APP DR SET

Wet lacquer inclusion removal set

APP DR SET is a needle set for removing inclusions from the wet top coat lacquer layer. The set consists of a pen-shaped grip with a mount and aglet, and 10 pieces of individually packed needles. The needles mounted in the mount of the grip feature microscopic hooks that allow to effectively catch and remove inclusions from the wet lacquer surface.

➤ ADVANTAGES

- simple method of inclusion removal from wet lacquer
- minimizes damage and the polishing time
- secure needle fastening in the mount
- aglet protecting the needle from contamination and damage
- aglet clasp fastening the grip to the spray-painting overalls pocket
- case for holding the set and APP DR SET REFILL spare needle kit

APP NO.	Description
250025	1 grip + 10 needles



• APP DR SET REFILL

Wet lacquer inclusion removal set

APP DR SET REFIL is an additional set of 10 needles for fastening in the inclusion removal grip mount. The needles feature microscopic hooks that allow to effectively catch and remove inclusions from the wet lacquer surface.

➤ ADVANTAGES

- simple method of inclusion removal from wet lacquer
- minimizes damage and the polishing time
- secure needle fastening in the mount
- ability to work without the grip and mount
- needles packaged individually in a transparent, heat-sealed blister pack

APP NO.	Description	Sales unit
250026	1 grip + 10 needles	pack. (10 pcs.)



• APP SDW

Lacquer defect removal cutter

Cutter for removing inclusions and small tears from cured lacquer surfaces. The very hard, precise and sharp edges do not require sharpening, as a result, the tool remains good as new and ready to use. The ideally smooth surface allows to easily and quickly obtain an even top coat lacquer surface, which shortens the time required for preparation works before polishing.

APP NO.	Description
250004	lacquer defect removal cutter



• APP NDZ

Tear removing knife (cutter)

A knife from specially shaped, high grade steel that easily cuts any irregularities protruding above the lacquer surface. The grip with a magnetic knife mount enables adjustment of the cutting height.

APP NO.	Description
250003	tear removing knife (cutter)

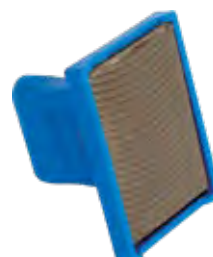

• APP M991 Waterproof sandpaper

Waterproof sandpaper in 230 mm x 280 mm sheets, intended for manual wet grinding. It can be used wherever the highest quality of the sanded surface is required.

▶ ADVANTAGES

- uniform closed type coating enables precise and even surface grinding, creating an ideal surface for top coat lacquers
- the incorporated sharp, silicon carbide allows for particularly effective surface grinding
- the synthetic resin binder ensure maximum protection against abrasive grain chipping
- elastic, impregnated paper with anti-slip structure



APP NO.	Description	Color	Size	Sales unit	Col. Pack.
40MW1500	P1500	blue	230 mm x 280 mm	pack. (50 pcs.)	10 pcs.
40MW2000	P2000	blue	230 mm x 280 mm	pack. (50 pcs.)	10 pcs.
40MW2500	P2500	blue	230 mm x 280 mm	pack. (50 pcs.)	10 pcs.
40MW3000	P3000	brown	230 mm x 280 mm	pack. (50 pcs.)	10 pcs.
40MW5000	P5000	brown	230 mm x 280 mm	pack. (50 pcs.)	10 pcs.
40MW7000	P7000	brown	230 mm x 280 mm	pack. (50 pcs.)	10 pcs.

• APP 991 AK 150 i APP 991 AK 75 Waterproof abrasive disk d150 and d75, Velcro fastened velcro

Velcro fastened, waterproof abrasive disks for mechanical wet grinding. Intended for mechanical removal of surface defects on cured lacquer prior to polishing. The abrasive material should be used in combination with a soft sponge or micro-rubber separator.

The grain size is designated by Velcro colors:
blue -P1500,
orange -P2000,
white -P2500.

▶ ADVANTAGES

- the uniform, closed type coating allows for precise and even sanding of surfaces, creating an ideal substrate for top coat paints
- the incorporation of sharp silicon carbide grain enables particularly effective surface sanding
- the synthetic resin adhesive ensures maximum security against chipping of grains



991 AK 150

APP NO.	Description	Color	Size	Sales unit
06MK1000	P1000	blue	d150	pack. (100 pcs.)
06MK1200	P1200	blue	d150	pack. (100 pcs.)
06MK1500	P1500	blue	d150	pack. (100 pcs.)
06MK2000	P2000	orange	d150	pack. (100 pcs.)
06MK2500	P2500	white	d150	pack. (100 pcs.)

991 AK 75

APP NO.	Description	Color	Size	Sales unit
06MD1500	P1500	blue	d75	pack. (100 pcs.)
06MD2000	P2000	orange	d75	pack. (100 pcs.)

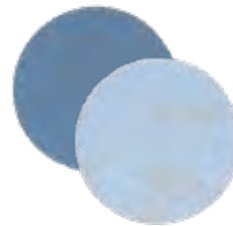

• APP MXR i APP MX Waterproof sanding pads – Velcro and glue fastened

Sanding pads intended for removing minor defects (dust dents and small water stains) on the surface of cured top coat paint and lacquers. They are used for spot finish sanding prior to polishing. The advantage of these pads is their undulating shape on the edges which, when properly placed on a block or work disk eliminates edge jamming, even during machine grinding using eccentric grinders. Intended for both manual and mechanical work.

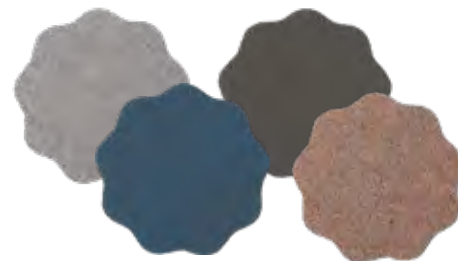

APP NO.	Description	Fastening	Size	Single Pack.
40MX1500	P1500	glue	35 mm	12 pcs.
40MX2000	P2000	glue	35 mm	12 pcs.
40MX2500	P2500	glue	35 mm	12 pcs.
40MX5000	P5000	glue	35 mm	12 pcs.
150401	block	for glue	35 mm	1 pcs.
40MXR1500	P1500	velcro	35 mm	12 pcs.
40MXR2000	P2000	velcro	35 mm	12 pcs.
40MXR2500	P2500	velcro	35 mm	12 pcs.
150409	ALU block	glue + velcro	30 mm	1 pcs.



block



ALU block

sanding pads

• APP PSK

Glue fastened abrasive pads on foil

Abrasive pads on a polyester foil base intended for removal of minor defects (dust dents and small water stains) on the surface of top coat lacquers. The new type grain coating made using the micro-replication method guarantees maximum precision and efficiency during work. The pads are intended for manual spot finish grinding prior to polishing, on APP KG MX or APP KA PSK blocks, and for mechanical work using the NTools PSM30 vibratory grinder. The pads can be used for dry as well as wet work when slightly moistened. Fastened to work blocks and disks using glue.

➤ ADVANTAGES

- remove minor painting defects thoroughly, quickly and precisely
- five times greater efficiency compared to pads with traditional grain coating
- do not clog during work and do not form springs
- create an even and easy to polish surface
- easy and quick use

APP NO.	Gradation	Fastening	Dimensions	Single Pack.
40PSK1500	P1500	glue	32 mm	12 pcs.
40PSK2000	P2000	glue	32 mm	12 pcs.
150409	ALU block	glue+velcro	32 mm	1 pcs.



• APP Carbon

Abrasive block

Pressed abrasive material for finish grinding prior to polishing. Intended for removal of inclusions, water stains and unevenness on cured painted surfaces and in painless removal of dents (PDR – Painless Dental Removal). For use on all types of cured top coat paints and lacquers.

APP NO.	Description	Color
06CAR0800	P0800	grey
06CAR1000	P1000	dark grey
06CAR1500	P1500	yellow
06CAR2000	P2000	green
06CAR3000	P3000	brown

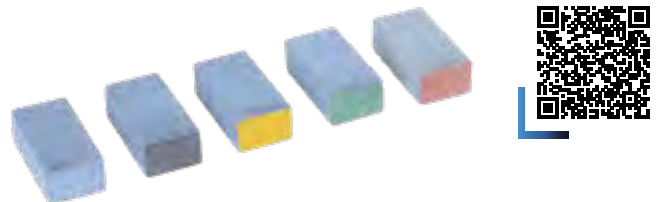

• APP QUARTZ Q401

Abrasive disk on film d150, grey colored, 14+1 holes, Velcro fastened

The APP QUARTZ Q401 abrasive disks are high quality abrasive materials on a synthetic film base. The durable abrasive grain made from fine artificial corundum in an open coating, covered with an excess of water-dilutable stearic compound enables efficient work on soft and dusting surfaces and materials of significant hardness, e.g. stainless steel. The abrasive disks are intended exclusively for dry work and fastened with Velcro.

➤ ADVANTAGES

- new type of stearic compound coating with very high clogging resistance
- low working temperature
- even and hard grain, resistant to dulling, ensures high grinding efficiency
- aggressive and efficient work in all gradations
- grain embedding resistant to chipping, high temperatures and high loads
- strong base resistant to tearing and edge delamination
- long working time
- very good surface finishing, e.g. for top coat lacquer or prior to polishing

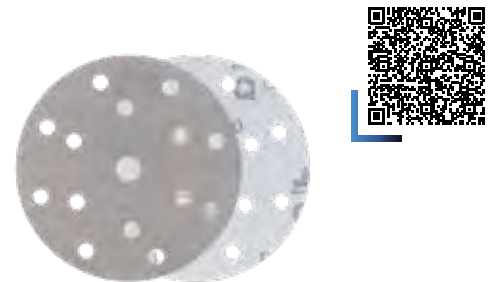

APP QUARTZ Q401 / Abrasive disk on film 14+1 otworów

APP NO.	Description	Color	Size	Sales unit
40FMQ1500	P1500	grey	d150	pack. (100 pcs.)
40FMQ2000	P2000	grey	d150	pack. (100 pcs.)
40FMQ2500	P2500	grey	d150	pack. (100 pcs.)

• APP CLAY BAR

Plastic mass for cleaning smooth surface - clay

Plastic mass intended for mechanical removal of contaminants from lacquered and glass surfaces such as car bodies, windshields, polycarbonate and glass headlights. Through adhesion, it reliably and quickly removes contaminants such as lacquering dry spray to facilitate polishing, industrial sediments, volatile rust, resin from trees, insect remains, etc. The product does not cause a decrease in gloss or other damage to the cleaned surface, is non-toxic, inflammable, easy to use, in specific cases can replace high granulation abrasive materials. The mass is designed for wet work.

➤ ADVANTAGES

- the blue APP Clay Bar mass has a more gentle effect and is designed for use on lacquers with lower hardness and in darker colors
- the red APP Clay Bar mass is more aggressive and is designed for use on hard lacquers and lacquers in brighter colors

APP NO.	Description	Color	Weight	Col. Pack.
080802	aggressive	red	200 g	100 pcs.
080803	gentle	blue	200 g	100 pcs.



• APP Clay Mitt

Car body decontamination glove

APP Clay Mitt allows cleaning of lacquered and glass surfaces (bodywork, windshields, headlights). The glove does not cause damage to the surface and is easy to use. Intended for use on all types of top coat lacquers. The glove's polymer surface removes stains reliably and quickly. It performs excellently on both flat surfaces, as well as all kinds of arches, convexities and concavities in car bodies.

➤ ADVANTAGES

- comfortable to use
- does not cause scratches
- does not damage the surface
- does not leave smudges
- multiple use



APP NO.	Description
220282	car body decontamination glove

• APP QUARTZ Q801

Coarse grain polishing paste

The APP QUARTZ Q801 polishing paste is intended for removal of scratches and surface matting on the car bodywork, giving it a high gloss. In order to fully take advantage of the Q801 paste's capabilities, we recommend using them with polishing sponges in the QUARTZ line. In case of polishing dark colored surfaces, as a finishing paste we recommend using the multifunctional APP QUARTZ Q802 polishing paste. The APP QUARTZ Q801 paste does not contain silicone, wax, or aggressive solvents.

➤ ADVANTAGES

- for use on HS and UHS lacquers
- does not contain silicone and ammonia
- extended working time
- low susceptibility to material heating
- for use with RP rotary polishers and DAP eccentric polishers



APP NO.	Color / Option	Weight	Col. Pack.
081372	white	100 g	50 pcs.
081374	white	500 g	12 pcs.
081370	white	1,0 kg	6 pcs.

• APP QUARTZ Q802

Multifunctional polishing paste

The APP QUARTZ Q802 multifunctional polishing paste is a high quality emulsion intended for quick removal of scratches and surface matting on the car bodywork. The incorporation of high quality ingredients guarantees high effectiveness and comfort of work. The APP QUARTZ Q802 is designed for use on hard, old lacquering coats and freshly lacquered surfaces. It is great at eliminating scratches and holograms, restoring a lasting and very high gloss.

➤ ADVANTAGES

- for use on HS and UHS lacquers
- excellent end result – very high gloss
- no tendency to create holograms
- does not contain silicone and ammonia
- extended working time
- low susceptibility to material heating
- for use with RP rotary polishers and DAP eccentric polishers



APP NO.	Color / Option	Weight	Col. Pack.
081373	white	100 g	50 pcs.
081376	white	500 g	12 pcs.
081371	white	1,0 kg	6 pcs.

• APP QUARTZ Q803

Carnauba Wax

APP QUARTZ Q803 Carnauba wax is a high quality natural, hard wax for protecting lacquer surfaces after polishing. It provides very high gloss with a mirror effect on the protected surface. The wax protects the lacquer and its gloss against the effects of adverse weather conditions. In case of application of the wax onto plastic materials, the product renovates them without leaving a white residue like most of these types of products.

➤ Method of use:

- apply a small amount on the polished surface
- wait until dry
- polish mechanically or manually using the APP QUARTZ Q806 cloth



APP NO.	Weight	Col. Pack.
081321	300 g	12 pcs.

• APP P1500 Fast Cut & FINISH Multi-purpose polishing paste

APP P1500 Fast Cut & FINISH is a universal polishing emulsion. It removes medium depth scratches and matting, giving the surface a high gloss. It is designed for use on old, oxidized lacquer coats during their renovation, on refinishing lacquers during paint and bodywork repairs, furniture lacquers and gel coats. Does not contain silicone, waxes and aggressive solvents.

➤ ADVANTAGES

- for use on HS and MS lacquers
- extended working time
- low susceptibility to surface heating
- does not contain silicone, ammonia, wax
- can be used on RP rotary polishers and DAP eccentric polishers

APP NO.	Weight	Col. Pack.
081352	100 g	50 pcs.
081348	500 g	12 pcs.
081350	1,0 kg	6 pcs.



• APP P01 Intensive Compound Multi-purpose polishing paste

APP P1500 Fast Cut & FINISH is a universal polishing emulsion. It removes medium depth scratches and matting, giving the surface a high gloss. It is designed for use on old, oxidized lacquer coats during their renovation, on refinishing lacquers during paint and bodywork repairs, furniture lacquers and gel coats. Does not contain silicone, waxes and aggressive solvents.

➤ ADVANTAGES

- for use on HS and MS lacquers
- extended working time
- low susceptibility to surface heating
- does not contain silicone, ammonia, wax
- can be used on RP rotary polishers and DAP eccentric polishers

APP NO.	Weight	Col. Pack.
081290	760 g	12 pcs.
081293	1500 g	8 pcs.
081296	7600 g	30 pcs.



• APP P03 Heavy Duty Compound Abrasive polishing compound coarse grained

Polishing Paste P03 is silicon-free coarse-grained polishing emulsion, consisting of extremely effective abrasive particles and non-aromatic hydrocarbons dissolved in water. Due to the use of mutually adjusted anti-adhesive components, P03 paste guarantees maximum intensity of abrading. It is designed for manual and mechanical polishing. It removes local paint defects which were formed when the vehicle was painted, defects of surfaces of old paint coatings caused with mechanical or thermal factors.

APP NO.	Weight	Col. Pack.
081301	600 g	12 pcs.
081304	1200 g	12 pcs.
081307	6000 g	30 pcs.



• APP P06 Medium Duty Compound Abrasive polishing compound medium grained

The P06 polishing paste is a silicone-free, medium-grained polishing emulsion. Properly matched abrasive and cleaning components guarantees an efficient and simple renovation of the old lacquer surface. Application: for manual and machine work and for the reconditioning of extremely aged, old lacquer surfaces. Moreover, the paste is designed for the removal of surface scratches, cleaning and the reconditioning of chromium plated elements, and as the second stage of polishing after the P03 polishing paste.

APP NO.	Volume	Pack. zb
081310	500 ml	12 pcs.
081313	1000 ml	12 pcs.



• APP P10 Leveling Compound

Polishing compound fine-grained

The P10 polishing paste is a fine-grained polishing emulsion. A balanced combination of hard waxes, polishing agents, anti-adhesive agents and cleaning components guarantees maximum effective and simplified use during manual or machine polishing and glazing. As a result of applying the P10 polishing paste, we obtain a permanently preserved lacquer surface with a very high gloss level. Application: for manual and machine work, protection and maintenance of new lacquer coats, protection of lacquer coats after renovation, maintenance of chromium plated elements, and as the second stage of polishing after the APP P03 or APP P06 polishing pastes.

APP NO.	Volume	Col. Pack.
081316	500 ml	12 pcs.
081319	1000 ml	12 pcs.



• APP 1STEP Universal Compound

Single operation – single step glossing and polishing paste – in a single step

It restores and adds high gloss to matted and scratched lacquered surfaces. It can be used on NANO lacquers. The product can be used to remove tree resin, insect remains, bird droppings, glue, tar and asphalt residue. Apart from polishing and cleaning, the APP 1STEP paste excellently restores and preserves lacquered surfaces. It is suitable for chrome-plated elements. The product does not contain silicone and is designed for work in paint-shops for quick finishing works after repairs. It can be used to maintain new cars in car showrooms. Versatile application, simplicity and ease of use, deep gloss effect for use at used car sales and maintenance points.

APP NO.	Volume	Col. Pack.
081340	500 ml	12 pcs.
081343	1000 ml	12 pcs.



• NTools WP 125 i Ntools WP 150

Work disks with a diameter of d125 and d150 for RP rotary polishers with an M14 thread

The NTools WP125 and NTools WP150 work disks with an M14 thread are intended for work with rotary polishers with the same thread, and Velcro fastened wools and sponges. The disks are made from elastic polyurethane (PU) that coats an aluminum core.



150521



APP WP 125

➤ ADVANTAGES

- polyurethane (PU) with Velcro for mounting polishing wools and sponges
- aluminum core with an M14 thread for mounting the work disk to the polisher
- NTools WP 125 has a diameter of 125 mm and is intended for work with Velcro fastened wools and sponges with diameters from 125 to 150 mm
- NTools WP 150 has a diameter of 150 mm and is intended for work with Velcro fastened wools and sponges with diameters from 150 mm to 180 mm
- low height (thickness) and precise balancing guarantee stable work and high comfort during extended polishing of various surface types

APP NO.	Description	Option	Size
150521	velcro	M14	d125
150522	velcro	M14	d150



150522



APP WP 150

- **APP TR 150**

Work disk with a diameter of d150 for RP rotary polishers with an M14 thread

APP TR 150 150 mm diameter work disk with a tube for centering the sponge and wool pad. It is designed for use with polishing wools and sponges with a diameter of 150 mm and above. The tube is used for centered fastening the heavy wool or sponge on the work disk, eliminating polisher knocking and vibrations.

APP NO.	Description	Option	WSize
150515	velcro + tube	M14	d150



- **APP TR 125**

Work disk with a diameter of d125 for RP rotary polishers with an M14 thread

APP TR 125 work disk with a diameter of 125 mm and a 30 mm thick PU dampening foam. It is intended for use with the Velcro fastened polishing sponge system with a diameter from 135 mm to 150 mm and thickness of 25 mm.

APP NO.	Description	Option	Size
150507	velcro	M14	d125 / h30



- **APP TR 70**

Work disk with a diameter of d70 for rotary polishers with an M14 thread

The APP TR 70 70 mm diameter work disk is intended for use with the Velcro fastened polishing sponge system with a 75 mm diameter.

APP NO.	Description	Option	Size
150506	velcro	M14	d70



• NTools TR 150U i TR 125U

Velcro fastened d150/(14+1)h and d125/(8+1)h work disks for eccentric DAP grinders and polishers, with an M8 or 5/16" UNF thread and screw.

The NTools TR 150U and TR 125U work disks fastened with an M8 or 5/16" UNF slot and screw are designed for work with Velcro fastened d150 abrasive disks with 6, 6+1, 8+1, 14+1 suction and polishing sponge pads > d150 for TR 150U disks with a 150 mm diameter and d125 with 8+1 suction holes, and polishing sponge pads > d 125 for TR 125U disks with a diameter of 125 mm.



APP TR 150U



150509

› Work disk structure:

- laminated fiberglass core with a riveted steel connector and steel insert with a locking slot, guaranteeing high stability and reliability
- polyurethane (PU) work part
- Velcro with increased grip and mechanical strength
- work disk mounting on the machine is done using a slot and steel screw with an M8 thread or screw with a 5/16" UNF thread

The disks are designed for use with eccentric grinders and polishers: NTools DAP I and II; RUPES (LHR21, LHR15; SKORPIO I, II, III; ER03/05TE;ER155TE; BR106/109/112AES); FESTOOL (ETS150 and 125), MAKITA B06030, and all others with an M8 or 5/16" UNF slot and screw mounting.



APP TR 125U



150508

APP NO.	Description	Option	Size
150508	8 + 1 holes	slot + M8 & 5/16" UNF	d125/h15
150509	14 + 1 holes	slot + M8 & 5/16" UNF	d150/h15

• APP QUARTZ Q804 i Q805

Velcro fastened, open cell polishing sponge pads with a diameter of d145 and d160

The APP QUARTZ Q804 and Q805 polishing sponges are modern polishing pads designed for use with Q801 and Q802 polishing pastes in the APP QUARTZ line. They are characterized by increased density and firmness of the open-cell foam, notches on the work surface that improve even paste distribution, and a central cooling hole. These elements intensify and facilitate polishing. They allow to maintain stable work temperature. They are compatible with RP rotary polishers and DAP eccentric polishers, and their new structure improves work comfort and facilitates polishing.

APP NO.	Description	Option / Size	Sales unit	Col. Pack.
080010	APP QUARTZ Q804 hard / white	polishing pad d 160, velcro, h 3 cm	pack. 2 pcs.	20 pcs.
080012	APP QUARTZ Q804 hard / white	polishing pad d 145, velcro, h 3 cm	pack. 2 pcs.	20 pcs.
080011	APP QUARTZ Q805 medium / orange	polishing pad d 160, velcro, h 3 cm	pack. 2 pcs.	20 pcs.
080013	APP QUARTZ Q805 medium / orange	polishing pad d 145, velcro, h 3 cm	pack. 2 pcs.	20 pcs.
080014	APP QUARTZ Q804 & Q805 set	polishing pad set d 160, velcro, h 3 cm	pack. 2 pcs.	20 pcs.
080015	APP QUARTZ Q804 & Q805 set	polishing pad set d 145, velcro, h 3 cm	pack. 2 pcs.	20 pcs.

APP QUARTZ Q804



APP QUARTZ Q805



APP QUARTZ Q805 Q805

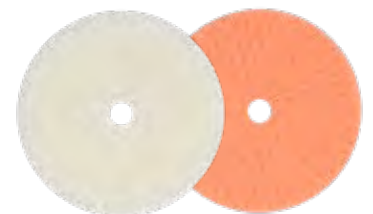

• APP QUARTZ Q811

Velcro fastened, layered polishing sponge pad with a diameter of d135 and d160

The APP QUARTZ Q811 layered polishing sponge is an innovative product intended for use with polishing pastes available in the APP offer. The layered firmness change system with a very firm and elastic carrier foam combined an open-cell foam, featuring a transversely notched PU foam work surface, places the Q811 sponge pad among the most sophisticated polishing tools.

➤ ADVANTAGES

- the carrier and work foam operating in tandem equalizes pressure on the polished surface
- very firm and elastic carrier foam increases work stability and comfort
- high firmness and transverse notch on the work foam's surface reduce polishing time
- carefully chosen work foam thickness minimizes the risk of cuts on the edges of polished elements
- the notches on the work foam's surface evenly distribute paste and intensify its effects
- the open-cell structure of the work foam stabilizes the temperature of the polished surface, reducing the risk of forming holograms

APP NO.	Color	Size
080019	white	d135 h25
080020	white	d160 h25



• APP QUARTZ Q809 i Q810

Set of d150 diameter, Velcro fastened polishing pads with a microfiber layer

The APP Quartz Q809 and Q810 polishing pads with a microfiber layer are a modern solution for the car body painting and detailing industry. Made from high quality polyurethane foam with two firmness levels and fine micro-fibers. APP Quartz Q809 is designed for initial polishing, while APP Quartz Q810 is for finish polishing. APP Quartz Q809 and Q810 are intended for work with Q801 and Q802 polishing pastes in the APP Quartz product line. The pad is compatible with DAP eccentric polishers.

APP NO.	Option	Color	Size	Sales unit
080018	velcro	green / blue	d130 / 150 h20	2 pcs.



• APP GP 150 R, GP 150 PR, GP 180 PR, GP 75 R

Smooth and profiled polishing sponge pads with diameters from d75 to d180, fastened with Velcro

Polishing sponge pads made from classic PU foam in five colors, five firmness grades, and two types of work surfaces: smooth and profiled.

➤ ADVANTAGES

- white – firm sponge for coarse, cutting pastes
- orange – medium firm sponge for medium grain and single-step pastes
- yellow – universal sponge for medium grain and anti-hologram pastes
- blue – finish sponge for anti-hologram finishing works
- black – very soft sponge for shellac glaze and waxes

The polishing sponge pads are compatible with APP and NTools Velcro work disks.

APP NO.	Model	Description	Color	Size	Col. Pack.
080105	APP GP 150 R	hard	white	d150	100 pcs.
080403	APP GP 150 R	universal	yellow	d150	140 pcs.
080305	APP GP 150 R	soft	black	d150	140 pcs.
080401	APP GP 150 PR	universal	blue	d150	140 pcs.
080405	APP GP 150 PR	universal	yellow	d150	140 pcs.
080306	APP GP 150 PR	soft	black	d150	140 pcs.
080501	APP GP 180 PR	universal	yellow	d180	100 pcs.
080503	APP GP 180 PR	soft	black	d180	100 pcs.
080550	APP GP 75 R	hard	white	d75	-
080551	APP GP 75 R	universal	orange	d75	-
080552	APP GP 75 R	soft	black	d75	-



APP GP 150 R



APP GP 150 PR



APP GP 180 PR



APP GP 75 R



• APP M14 Foam Pad i GP 150 M

Smooth polishing sponge pads with a diameter of d150, fastened on an M14 thread

150 mm diameter polishing sponge pads made from classic PU foam in four colors, four firmness grades, and one, smooth work surface type.

> Types

- white – firm sponge for coarse, cutting pastes
- orange – medium firm sponge for medium grain and single-step pastes
- yellow – universal sponge for medium grain and anti-hologram pastes
- black – very soft sponge for shellac glaze and waxes

The polishing sponge pads are compatible with RP rotary polishers equipped with an M14 thread connector.

APP NO.	Model	Description	Color
080110	APP M14 Foam Pad	hard	white
080115	APP M14 Foam Pad	medium hard	orange
080120	APP M14 Foam Pad	universal	yellow
080125	APP M14 Foam Pad	soft	black
080102	APP GP 150 M	hard	white
080402	APP GP 150 M	universal	yellow
080202	APP GP 150 M	universal	orange
080302	APP GP 150 M	soft	black



APP M14 Foam Pad



APP GP 150 M

• APP Wool 180

Rigid polishing wool with a rim, d180 diameter, fastened with Velcro

A polishing and glossing wool for surfaces of very hard top coat lacquers and gel coats. Made from naturally woven wool on a very durable and elastic base. It is designed to be compatible with the APP TR 150 work disk and for use on extremely hard surfaces.

APP NO.	Size
080612	d180



• APP Wool 150

Tied polishing wool with a diameter of d150

A polishing and glossing wool for lacquered surfaces. Made from natural wool on a natural base. It is designed for work on hard top coat lacquers and quick restoration of old, oxidized lacquer coats. It is compatible with the APP GA 125 work disk.

APP NO.	Size
080605	d150



• APP QUARTZ Q806

Microfiber dusting cloth

APP QUARTZ Q806 is a specialized microfiber cloth made from very soft microfibers, designed for final polishing of lacquer. It is intended for removal of polishing paste residue and application and polishing of all kinds of shellac glazes, waxes or "quick detailers". The cloth's edges are not hemmed with fabric, are very soft, and do not cause scratches on the lacquer. The APP QUARTZ Q806 cloth is very absorbent and can also be used for drying the car's body after washing. Cloth dimensions: 40 x 40 cm. Area density 600 g/m². Composition: 80/20 polyester/polyamide.

> ADVANTAGES

- universal application
- very soft, with dense fibers
- highly absorbent
- no hemming on the edges

APP NO.	Color	Size
080646	navy blue	40 x 40 cm



• APP MF Cloth

Microfiber dusting cloths

Dust absorbent microfiber cloths designed for use in performing a wide range of activities. Cloth dimensions: 40 x 40 cm.



› TYPES

- MF Cloth – green (APP NO. 080648) – perfectly suited for polishing glass, ceramics, stainless steel, mirrors, windshields, and cleaning plastic elements. Surface density 360 g/m². Composition 80/20 polyester/polyamide
- MF Cloth – navy blue (APP NO. 080649) – highly absorbent cloth with a specially harder fiber weave, for complete removal of wax and polishing paste residue left on the polished element for an extended time. Surface density 380 g/m². Composition 70/30 polyester/polyamide
- MF Cloth – orange (APP NO. 080650) – the cloth features two different microfiber lengths on each side of the surface, allowing for faster and more precise removal of all kinds of staining and contaminants. Surface density 360 g/m². Composition 80/20 polyester/polyamide



APP NO.	Description	Color	Size	Sales unit	Col. Pack.
080648	-	green	40 x 40 cm	pack. (3 pcs.)	10 pcs.
080649	-	navy blue	40 x 40 cm	pack. (3 pcs.)	10 pcs.
080650	dual-function	orange	40 x 40 cm	pack. (3 pcs.)	10 pcs.

• APP Clean Soft

Non-dusting polishing cloths

APP Clean Soft are special non-woven, non-dusting polishing cloths that leave no smudges or stains. Very absorbent, strong and resistant to mechanical damage. Work perfectly with water, solvents, detergents and oils. They are intended for use in car workshops and paint-shops, mechanical workshops, as well as in the food and pharmaceutical industry. For use with specialized preparations on surfaces sensitive to scratching. They significantly speed up finishing works. Dimensions: 40 x 30 cm. Surface density: 20 g/m². Composition: 70/30 viscose/polyester.



APP NO.	Color	Size	Sales unit
090421	white	40 x 30 cm	pack. (20 pcs.)

• APP Finish Test Spray

Preparation for assessing correctness of surface polishing

APP Finish Test Spray is a compound that allows to easily assess the correctness of surface polishing. Washing away waxes and shellac glaze reveals unremoved scratches and other concealed surface defects.

› ADVANTAGES

- comfortable to use
- quick and efficient
- saves time and money



APP NO.	Description	Volume	Col. Pack.
210910	foam	400 ml	6 pcs.

• NTools FP 1

Polishing apron

Protective polishing apron made from cotton, protecting the polished surface against scratches from buttons or belts. Convenient pockets are located in the front part of the apron.

› ADVANTAGES

- comfortable to use
- quick and efficient
- saves time and money

APP NO.	Color	Size
090510	black	L / XL



SPRAY-PAINTING



OHS

21-232 SPRAY-PAINTING

- 21-28 Putties and fillers
- 29-36 Base and primers
- 37-46 Top coats
- 47-56 Modular color selection system
- 57-62 Thinners, removers and additives
- 63-67 Repair of plastics
- 69-76 Adhesives and sealants
- 77-84 Car body protection and soundproofing
- 85-96 Abrasives
- 97-106 Masking systems
- 107-118 Polishing
- 119-126 • OHS**
- 127-132 Fabric filters and spray-painting booth accessories
- 133-154 Workshop auxiliary equipment
- 155-170 Various spray-painting products
- 171-178 Spray guns and extruders
- 179-186 Pneumatic grinders
- 187-192 Electric grinders, heat guns and lamps
- 193-198 Work disks
- 199-204 Dust extraction
- 205-208 Radiators
- 209-218 Pneumatics
- 219-222 Spray gun regenerators and washers
- 223-232 Technical sprays

• APP Compact CT

Two-layered, cellulose technical cleaning paper

The APP Compact CT cellulose technical cleaning paper is a two-layered cleaner with versatile applications. It is characterized by high effectiveness and efficiency of use. The paper is highly absorbent and the perforated sections enable precise length dispensation. It effectively absorbs oils and easily removes all kinds of greases. The APP Compact CT is intended for use at paint-shops, mechanical workshops and printing houses for cleaning surfaces prior to applying bases, fillers, for cleaning cars, wiping tools, workshop tables, hands, etc.

➤ TECHNICAL PARAMETERS

- material: 100% cellulose
- layers: 2
- number of sections: 1500 pcs.
- section length: 380 mm
- section width: 265 mm
- roll length: 570 lm
- roll diameter: 390 mm
- surface density: 2 x 19 g/m²
- color: white

APP NO.	Color	Dimensions	Col. pack.
090417	white	540 mb	2 pcs.



• APP Standard CT

Two-layered, cellulose technical cleaning paper

The APP Standard CT is a to-layered, waffled cleaning paper with increased mechanical strength and low dusting. It is intended for use at paint-shops for cleaning surfaces prior to lacquering, applying bases, fillers. It can also be used at mechanical workshops and printing houses for wiping tools, workshop tables or hands.

➤ TECHNICAL PARAMETERS

- color: white
- surface density: 2 x 20 g/m²
- roll width: 26 cm
- section length: 30,5 cm
- paper roll length: 244 m
- number of sections: 800 pcs.

➤ ADVANTAGES

- does not leave lint – perfect for areas sensitive to dusting
- efficient and durable – can be used to wipe uneven and sharp surfaces
- soft to the touch – allows to precisely clean surfaces in complex shapes
- quickly and effectively absorbs organic cleaning products and solvents, water, detergents and oils
- perforations between sections allow for convenient and precise dispensation

APP NO.	Color	Dimensions	Col. pack.
090413	white	240 mb	2 pcs.



• APP Premium

CThree-layered, cellulose technical cleaning paper

APP Premium is a to-layered, waffled cleaning paper with very high mechanical strength for wet wiping, and very low dusting. It is intended for use at paint-shops for final cleaning of surfaces prior to lacquering. It can also be used at mechanical workshops and printing houses for washing and wiping tools, workshop tables or hands.

➤ TECHNICAL PARAMETERS

- color: blue
- surface density: 3 x 20 g/m²
- roll width: 22 cm
- section length: 38 cm
- paper roll length: 190 m
- number of sections: 500 pcs.

➤ ADVANTAGES

- does not leave smudges
- does not leave dust and lint – perfect for areas sensitive to dusting
- efficient and durable – can be used to wipe uneven and sharp surfaces
- quickly and effectively absorbs organic cleaning products and solvents, water, detergents and oils
- perforations between sections allow for convenient and precise dispensation

APP NO.	Color	Dimensions	Col. pack.
090414	blue	170 mb	2 pcs.



• APP Wiskoza

Viscose technical wiping cloth

The APP Wiskoza nonwoven technical wiping cloth is a very high durability product manufactured from a mixture of polypropylene, polyester and cellulose pulp (20/30/50) for wet and dry wiping, characterized by low dusting. Intended for use at car body repair and paint-shops, mechanical workshops, as well as in the food and pharmaceutical industries. For polishing and cleaning delicate surfaces.

➤ TECHNICAL PARAMETERS

- color: white
- paper roll length: 140 m
- section length: 38 cm
- roll width: 32 cm
- surface density: 65 g/m²
- number of sections: 368 pcs.

➤ ADVANTAGES

- does not scratch high gloss lacquered surfaces
- does not leave smudges
- soft to the touch – allows to precisely clean surfaces in complex shapes
- efficient and durable – can be used to wipe uneven and sharp surfaces
- perforations between sections allow for convenient and precise dispensation

APP NO.	Description	Color	Dimensions
090415	perforated	white	140 mb



• APP H 01 Eco Clean

Paste for washing heavily contaminated hands

APP H 01 Eco Clean is a paste for washing heavily contaminated hands, manufactured based on wood meal and effective detergents. It does not irritate the skin and is clinically tested. The paste is intended for general use at car workshops, industrial plants and construction.

➤ ADVANTAGES

- excellently removes greases, oils and fats
- has a pleasant, refreshing scent
- does not contain hard or sharp abrasives
- nourishes and softens callouses on the hands
- an environmentally friendly, biodegradable product

APP NO.	Volume	Col. pack.
090202	0,5 L	12 pcs.
090201	1,0 L	-



• APP E 02 Extra Clean

Hand washing paste for spray-painters and mechanics

APP E 02 Extra Clean is a hand washing paste that gently removes persistent coloring substances. It does not irritate the skin. The paste is intended for use at bodywork and paint repair shops, industrial paint-shops, paint and lacquer mixing plants and printing houses.

➤ ADVANTAGES

- perfectly removes difficult to wash substances such as: one- and two-component base paints and lacquers, printing dyes, resins, grease and tar, and polyurethane foams
- does not contain hard and sharp abrasives or aggressive solvents
- nourishes and softens callouses on the hands caused by work
- an environmentally friendly, biodegradable product

APP NO.	Volume	Sales unit	Col. pack.
090101	0,5 L	pcs.	12 pcs.
090100	3,0 L	pcs.	-



• APP H 03 Handreninger

Highly contaminated hand washing gel for mechanics

APP H 03 Handreninger is a solvent-free handwashing gel that is neutral to the skin. It does not cause skin irritation. The gel is intended for use at bodywork repair and mechanical shops, transport hubs, tire repair shops, electromechanical service stations.

➤ ADVANTAGES

- contains a delicate abrasive intended for removing extremely concentrated contaminants such as oils and greases, bituminous products, resins, printing dyes, ink, etc.
- nourishes and softens callouses on the hands caused by work
- an environmentally friendly, biodegradable product

APP NO.	Volume
090200	4,5 L



• APP AIR Plus A1+P2 R Spray-painting half-mask

The APP AIR Plus A1+P2 R half-mask was designed for difficult working conditions in an environment of dust, aerosols and vapors of hazardous substances. The face section of the APP Air Plus half-mask is made from a mixture of thermoplastic elastomer (TPE) and polypropylene (PP), and perfectly adjusts to faces of different sizes. The head band system eliminates uncomfortable pressure points, ensuring comfort of use in case of extended half-mask use.

The half-mask is available in one, universal size. It is equipped with a bayonet system for fastening the absorbers, which are placed to ensure a wide field of view.

➤ ADVANTAGES

- universal size perfectly adjusting to most face shapes and sizes
- face section made from a soft elastomer ensuring tightness and comfort of use
- low breathing resistance thanks to silicone valves ensuring high tightness and ability to work in a wide range of temperatures
- high activated carbon Volume in the A1 absorbers ensures long exploitation time
- replaceable, multiple-use A1 absorbers and stably installed P2 R flat filters
- simple, quick, bayonet mounting system for the A1 carbon filter-absorbers
- the structure of the face section and filter-absorber and head band fastening locations do not restrict the field of vision
- durable, comfortable head bands equipped with durable, profiled fasteners, designed to not obstruct the field of view
- low face section weight – only 94g



➤ APPLICATION

When fitted with A1 absorbers and P2R filters, the APP half-mask is used to protect the respiratory system from organic gases and vapors of organic substances with a boiling temperature >65 °C at a total volume concentration not exceeding the value of 0,1% (class 1 absorbers) and aerosols of solid and liquid particles.

➤ INTENDED FOR USE IN:

- the automotive industry
- the chemical and wood industry
- during household appliance production
- in the aviation industry
- during construction of machines, processing of marble and welding works
- during all works requiring A1+P2 protection

AIR Plus

APP NO.	Description	Sales unit
090750	APP AIR Plus painting half-mask (set A1+P2 R)	pcs.

Akcesoria topółmaski lakierniczej APP AIR Plus

APP NO.	Description	Sales unit
090755	APP AIR Plus painting half-mask (face section)	1 pcs.
090760	A1 activated carbon absorber for the APP AIR Plus half-mask	2 pcs.
090761	P2 R flat dust filter for the APP AIR Plus half-mask	8 pcs.
090762	APP AIR Plus FPP flat dust filter for the	10 pcs.
090764	APP AIR Plus AFP 90 flat filter adapter	2 pcs.
090765	PF 90 flat filter cover for the APP AIR Plus half-mask	2 pcs.
090766	APP Air Plus WHS Air-tight string holding bag	1 pcs.



Akcesoria topółmaski lakierniczej APP AIR Plus

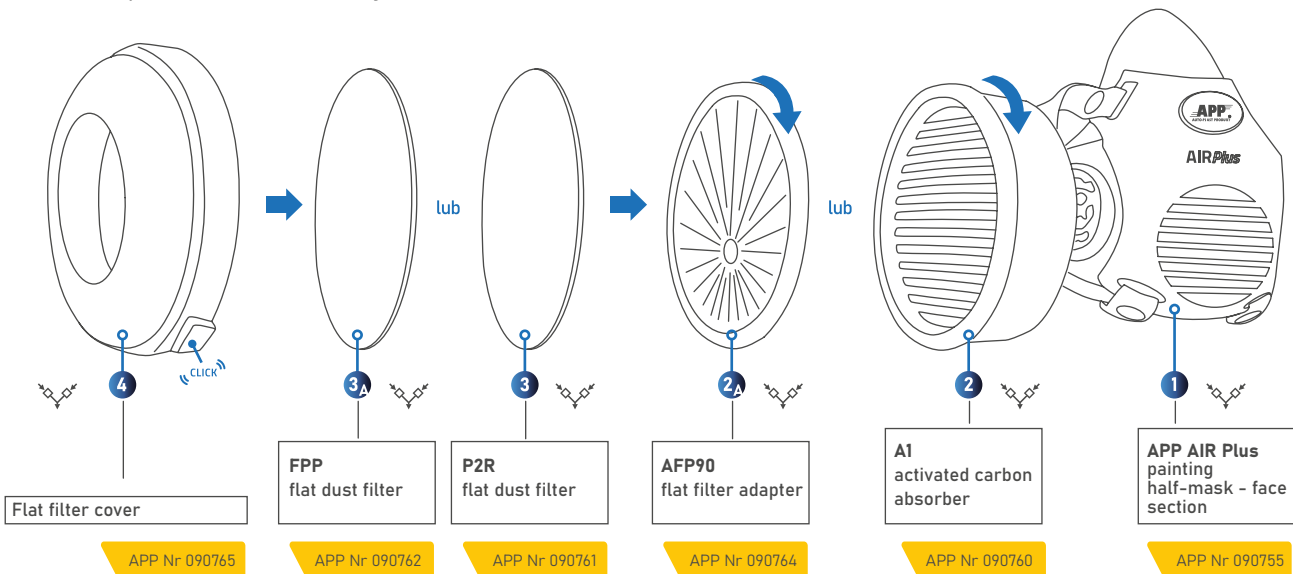

• APP KN95

FFP2 4-layered, disposable protective half-mask

The certified APP KN95 protective mask ensures high work comfort and meets all the requirements of the FFP2 filtration class, offering efficient filtration of PM2,5 particles suspended in the air (including bacteria and viruses) at a minimum level of 95%. It can be worn for several hours. The product is friendly to the skin.

The mask meets standards compliant with the EN 149 European norm. This means that the mask protects the respiratory system against dust, smoke, aerosol particles, and transmission of bacteria and viruses.

APP NO.	Color	Dimensions	Sales unit
091110	white	universal	pack. (10 pcs.)



• APP OKP 1

Polycarbonate protective glasses

The protective glasses secure against impact from solid particles in a temperature range from -5°C to +55°C. They are intended for use in situations where glare is not a significant risk factor. They feature an unobstructed field of view.

APP NO.	Color	Dimensions
091304	colorless	universal



• APP RN 100 i APP Quartz Q905

Nitrile protective gloves, disposable APP RN 100 COMPACT, APP RN 100 STANDARD and APP QUARTZ Q905 Extra Safe nitrile gloves

APP nitrile gloves ensure protection against chemical and mechanical hazards, while providing full comfort of use. Made from 100% nitrile. These disposable, powderless gloves do not irritate the skin and limit the risk of food contamination with corn starch normally used inside gloves. The APP nitrile gloves do not contain latex, silicone, waxes and plasticizers, are ambidextrous, odorless and non-sterile.

➤ ADVANTAGES

- additional layer of nitrile on the fingertips ensure excellent feel and manual dexterity, while also improving grip
- turned up cuff ensuring additional protection at the wrists, more secure fit and increased durability
- three times greater puncture and rupture resistance compared to disposable latex or PVC gloves
- high rupture resistance before use: 16 Mpa for RN100 STANDARD. The typical value for most commercially available gloves is 14 Mpa

➤ APPLICATION

- auto-repair (bodywork and paint repair shops)
- transport
- construction industry
- chemical industry
- electronic and precision industry
- food processing and services
- gardening
- pharmaceutical companies (laboratories)
- medical rescue

RN 100 COMPACT

APP NO.	Color	Dimensions	Sales unit	Col. pack.
090676	blue	S	pack. (100 pcs.)	10 pcs.
090677	blue	M	pack. (100 pcs.)	10 pcs.
090678	blue	L	pack. (100 pcs.)	10 pcs.
090679	blue	XL	pack. (100 pcs.)	10 pcs.



RN 100 STANDARD

APP NO.	Color	Dimensions	Sales unit	Col. pack.
090636	indigo	S	pack. (100 pcs.)	10 pcs.
090637	indigo	M	pack. (100 pcs.)	10 pcs.
090638	indigo	L	pack. (100 pcs.)	10 pcs.
090639	indigo	XL	pack. (100 pcs.)	10 pcs.



QUARTZ Q905 Extra Safe

APP NO.	Color	Dimensions	Sales unit	Col. pack.
090662	blue	S	pack. (100 pcs.)	10 pcs.
090663	blue	M	pack. (100 pcs.)	10 pcs.
090664	blue	L	pack. (100 pcs.)	10 pcs.
090665	blue	XL	pack. (100 pcs.)	10 pcs.



• NTools RRN 12B i RRN 12C Nylon-Polyurethane Industrial Gloves

NTools RRN 12B and NTools RRN 12C industrial gloves made from lint-free nylon fabric (13 stitch) coated with Polyurethane (PU) from the bottom (a gripping side). Gloves feature with high resistance to damage and offer firm grip of tools, materials and repaired elements. Seamless to ensure comfort with an elasticated cuff that ensures a snug fit. Available sizes: S (7), M (8), L (9) and XL (10) in black and white colour with red trimming of cuffs. NTools RRN 12B and NTools RRN 12C industrial gloves are free of latex, silicone and waxes. Gloves feature with high quality and mechanical strength (comply with EN 388) and offer comfort for users.

RRN 12B

APP NO.	Color	Dimensions	Sales unit
090804	white	S (7)	pack. (12pairs)
090803	white	M (8)	pack. (12 pairs)
090801	white	L (9)	pack. (12 pairs)
090802	white	XL (10)	pack. (12 pairs)



RRN 12C

APP NO.	Color	Dimensions	Sales unit
090808	black	S (7)	pack. (12pairs)
090807	black	M (8)	pack. (12 pairs)
090805	black	L (9)	pack. (12 pairs)
090806	black	XL (10)	pack. (12 pairs)



• APP RNW Nitrile gloves on a jersey lining

Nitrile gloves on a cotton jersey insert with a length of 30 cm and thickness of 1 mm, cuffs finished with a simple edge. Excellent abrasion resistance. Good nitrile resistance to chemical hazards. Insulation against cold and heat. Good resistance to tearing and puncturing as per EN 420:2003.

➤ APPLICATION

- industrial cleaning
- painting works
- spray-painting and lacquering
- work involving handling mineral oils
- surface processing
- transport of chemical products, hydrocarbons



APP NO.	Color	Dimensions	Col. pack.
090643	green	8,5	120 pcs.
090644	green	9,5	120 pcs.

• APP OR 01 Polyester and cotton work overalls

The APP OR 01 work overalls are made from a 65% polyester and 35% cotton mix with a surface density of 245 g/m². Fitting is done via the adjustable, elastic suspenders. The waist is buttoned from the side. Numerous pockets, including one broad, central pocket on the chest with a press stud fastened flap, and one pocket on each leg. For use in car repair shops, internal transport, warehousing, maintenance and clean-up works.

➤ ADVANTAGES

- large number of pockets increasing the pants' functionality
- elastic band in the suspenders increases comfort during work performed in different positions
- the incorporated materials and durability ensure high comfort of use
- parameters compliant with the requirements of European Directive 89/686 and the EN340:2003 norm

APP NO.	Color	Dimensions	Col. pack.
090620	grey-red	M	10 pcs.
090621	grey-red	L	10 pcs.
090622	grey-red	XL	10 pcs.
090623	grey-red	XXL	10 pcs.



• APP BR 02

Polyester and cotton work blouse

APP BR 02 work blouse made from 65% polyester and 35% cotton, with a surface density of Fastened with a zipper, with buttoned cuffs. Features a rubber welt at the bottom. The blouse has four pockets, including one small inner chest pocket with a press stud fastened flap and two open side pockets.

APPLICATION: car repair shops, internal transport, warehousing, maintenance and clean-up works.

› ADVANTAGES

- large number of pockets increasing the functionality of the blouse
- the incorporated materials and durability ensure comfort during work
- parameters compliant with the requirements of European Directive 89/686 and the EN340:2003 norm

APP NO.	Color	Dimensions	Col. pack.
090630	grey-red	M	10 pcs.
090631	grey-red	L	10 pcs.
090632	grey-red	XL	10 pcs.
090633	grey-red	XXL	10 pcs.



• APP KNB 50 i KNB 55

Nylon – cotton work coveralls

The APP KNB 50 and KNB 55 are light and durable, hooded work coveralls. They are fitted and sealed using elastic bands in the waist, ankles, wrists and hood. They protect clothing from staining with paint, dust and aerosols. The coveralls are also available without the APP logo. Applications: maintenance and cleanup works, light and medium-heavy works conducted in normal wear and staining.

› ADVANTAGES

- front nylon part limits penetrability and dust absorption of the coverall
- the back part made from breathable cotton ensures very good ventilation
- partially uncovered zipper
- the incorporated materials and durability ensure high comfort of use
- does not contain silicone



KNB 50

APP NO.	Description	Color	Dimensions	Col. pack.
090604M	-	grey-red	M	50 pcs.
090604S	-	grey-red	S	50 pcs.
090605	-	grey-red	L	50 pcs.
090606	-	grey-red	XL	50 pcs.
090608	-	grey-red	XXL	50 pcs.
0906081	-	grey-red	XXXL	50 pcs.
090604MB	no logo	grey-red	M	50 pcs.
090604SB	no logo	grey-red	S	50 pcs.
090605B	no logo	grey-red	L	50 pcs.
090606B	no logo	grey-red	XL	50 pcs.
090608B	no logo	grey-red	XXL	50 pcs.
0906081B	no logo	grey-red	XXXL	50 pcs.

KNB 55

APP NO.	Description	Color	Dimensions	Col. pack.
090680	-	white	S	10 pcs.
090681	-	white	M	10 pcs.
090682	-	white	L	10 pcs.
090683	-	white	XL	10 pcs.
090684	-	white	XXL	10 pcs.
090685	-	white	XXXL	10 pcs.
090680B	no logo	white	S	10 pcs.
090681B	no logo	white	M	10 pcs.
090682B	no logo	white	L	10 pcs.
090683B	no logo	white	XL	10 pcs.
090684B	no logo	white	XXL	10 pcs.
090685B	no logo	white	XXXL	10 pcs.



• APP AirMax Pro

Protective painting coverall

The APP AirMax Pro protective painting coverall is made from a durable, non-dusting, micro-porous material that ensures maximum protection against contact with dust and liquids (Type 5 and 6). The coverall features a 3-piece hood with flexible seals for the face hole, elastic sleeves, a two-part wedge in the crotch, elastic wrists, ankles and waist.

Increased protection against liquids and dust is provided by tight, inset overlock seams.

The APP AirMax Pro protective painting coveralls are CE certified and meet the requirements of applicable norms, including EN 14126 – they can be used as protective clothing against biological hazards, viruses and other contagious factors.

APP NO.	Color	Dimensions
090595	white	M
090596	white	L
090597	white	XL
090598	white	XXL



• APP OB 10

Shoe covers with anti-slip soles

Shoe covers with anti-slip soles made from a non-dusting, durable, microporous fabric that ensures maximum protection in contact with dust and liquids. They feature anti-slip soles and elastic bands that facilitate putting on and adjustment to the footwear.

➤ ADVANTAGES

- non-dusting, highly water-tight, microporous fabric protects against dust and liquids (protection: Type 5 and 6)
- anti-slip, damage-resistant soles guarantee durability and prevent slipping during use
- universal, one-size-fits all, and a design that makes the covers fit to any type of footwear

APP NO.	Color	Dimensions	Sales unit
090520	blue	universal	pack. (10 par)



• NTools Kamo

S1 work shoes with composite toe caps

The NTools Kamo shoes are made from a durable and breathable material ensuring high safety, hygienic properties and foot ventilation. The shoes feature composite toe caps protecting against impact up to 200 J (corresponding to impact of a 20 kilogram item falling from a height of 1 meter) and anti-slip soles. They are compliant with requirements for toe cap category S1 specified in the EN ISO 20345 norm.

➤ ADVANTAGES composite toe caps

- prevent cutting or crushing of toes
- do not conduct heat
- reduced toe cap weight (50% lower weight)
- do not corrode
- do not set off metal detectors

➤ ADVANTAGES NTools Kamo

- composite toe cap (impact resistance up to 200 J)
- energy absorption in the heel section
- anti-static properties
- resistance to petrol, oils, organic solvents
- light footwear
- breathable outer materials
- manufactured and tested in compliance with the EN ISO 20345 norm

APP NO.	Color	Dimensions	Col. pack.
092019	multicolor	39	10 par
092020	multicolor	40	10 par
092021	multicolor	41	10 par
092022	multicolor	42	10 par
092023	multicolor	43	10 par
092024	multicolor	44	10 par
092025	multicolor	45	10 par
092026	multicolor	46	10 par



SPRAY-PAINTING

1



Fabric filters and spray-painting booth accessories

21-232 SPRAY-PAINTING

- 21-28 Putties and fillers
- 29-36 Base and primers
- 37-46 Top coats
- 47-56 Modular color selection system
- 57-62 Thinners, removers and additives
- 63-67 Repair of plastics
- 69-76 Adhesives and sealants
- 77-84 Car body protection and soundproofing
- 85-96 Abrasives
- 97-106 Masking systems
- 107-118 Polishing
- 119-126 OHS
- 127-132 • Fabric filters and spray-painting booth accessories**
- 133-154 Workshop auxiliary equipment
- 155-170 Various spray-painting products
- 171-178 Spray guns and extruders
- 179-186 Pneumatic grinders
- 187-192 Electric grinders, heat guns and lamps
- 193-198 Work disks
- 199-204 Dust extraction
- 205-208 Radiators
- 209-218 Pneumatics
- 219-222 Spray gun regenerators and washers
- 223-232 Technical sprays

• APP V 500, APP V 600

Ceiling filters for spray cabins

The APP V500, V600 nonwoven and polyester filtration mats are intended for final filtration of intake air for spray-painting cabins as a roof filter for thorough purification of air in spray-painting systems. The progressively mounted filtration mat is impregnated with a binder in its entirety. The clean air side is reinforced with a woven fabric or polyester mesh. It does not contain silicone or other substances harmful to lacquer.

➤ ADVANTAGES

- progressive structure with a binder in the entire volume, providing high capacity for catching and accumulating dust, which ensures long-lasting and reliable operation
- woven polyester fabric ensures a uniform airflow, increases the stability of the nonwoven filtering fabric during shocks and vibrations caused by the turbines and prevents mechanical damage during installation
- high mechanical strength of the filtration mat guarantees dimensional stability throughout the entire service period, even at high airflow values
- flammability class DIN 53438-3 (F1) – slow-burning



V 500



V 600

Parameters		V 500	V 600
APP NO.	Roll 1,2 m x 20 mb	100206	100205
	Roll 1,5 m x 20 mb	100213	100211
	Roll 2,0 m x 20 mb	100203	100201
	Cut/m ²	100221	100220
Weight	500 g/m ²	600 g/m ²	
Thickness	225mm	225mm	
Airflow	900 m ³ /h	900 m ³ /h	
Initial capture	25 Pa	30 Pa	
Final capture	450 Pa	450 Pa	
Capture effectiveness	96,00%	97,00%	
Airflow speed	0,25 m/s	0,25 m/s	
Dust containment	550 g/m	650 g/m	
Max temp.	280°C	280°C	
Filtration class (DIN 24185)	F5	M5	
Fire resistance (DIN 53438)	F1	F1	
Filtration efficiency as per ISO 16890	ePM1055%	ePM1050%	

• APP FL 150 i APP FL 220

Initial filters for spray cabins

A nonwoven filtration mat intended for first stage filtration of intake air into the spray cabins and cabin-dryers as an initial filter, as well as a final filter at the outlet (before the exhaust turbine) in spray-painting systems.

➤ ADVANTAGES

- progressive structure providing high capacity for catching and accumulating dust, which ensures long-lasting and reliable operation
- high mechanical strength of the filtration mat guarantees dimensional stability throughout the entire service period, even at high airflow values
- the filtration mat's flexibility makes it possible to cut out pocket filters and filtration inserts in any chosen shape
- flammability class DIN 53438-3 (F1) – slow-burning

Parameters		FL 150	FL 220
APP NO.	Roll 2 m x 40 mb	103016	-
	Cut/m ²	103017	-
	Roll 2 m x 20 mb	-	103010
	Cut/m ²	-	103015
Thickness	11 mm	22 mm	
Airflow	5400 m ³ /h/m ²	5400 m ³ /h/m ²	
Initial capture	25 Pa	35 Pa	
Final capture	250 Pa	250 Pa	
Capture effectiveness	65-80%	>90%	
Dust containment	150 g/m ²	220 g/m ²	
Max temp.	800C	800C	
Filtration class (EN 779)	G2	G4	
Fire resistance (DIN53438)	F1	F1	



FL 220

• APP Pocket filters

Pocket filters

In spray cabins, initial air cleaning is executed using pocket filters. They are characterized by a greater filtration surface, which provides a longer utility period. The filters have the ability to capture air impurities which negatively affect the quality of the lacquer coating. Use of pocket filters extends the service life of roof filters and stabilizes overpressure in the spray cabin, increasing its efficiency. The utility period of those filters is estimated at approximately 300-350 hours, after which time, the used filters need to be replaced. In order to protect the natural environment and the exhaust turbine blades, spray cabin manufacturers place pocket filters between the floor filters and the exhaust turbine, ensuring additional filtration of air leaving the cabin. APP's offer includes pocket filters for all commonly used spray cabins. There is also the possibility to execute custom filters. Filtration class G4.

APP NO.	Type	Col. pack.
100306	Pocket filter PREMIUM G4 USI type C thickness 22mm 1x7 pockets with frame 1070mm x 523mm x 200mm	1 pcs.
100307	Pocket filter PREMIUM G4 USI type D thickness 22mm 1x8 pockets with frame 1168mm x 598mm x 200mm	1 pcs.
100310	Pocket filter PREMIUM G4 SAIMA cone type thickness 22mm 1 pocket with frame 415mm x 380mm x 600mm	1 pcs.
100321	Pocket filter PREMIUM G4 WBS thickness 22mm 1x4 pockets with frame 1182mm x 585mm x 300mm	1 pcs.
100352	Pocket filter PREMIUM G4 Blowtherm thickness 22mm 1x10 pockets with frame 1195mm x 595mm x 200mm	1 pcs.
100370	Pocket filter PREMIUM G4 typ SAIMA thickness 22mm 1x4 pockets with frame 590mm x 450mm x 700mm	1 pcs.
100390	Pocket filter PREMIUM G4 USI type MILLIBAR thickness 22mm 1x6 pockets with frame 785mm x 685mm x 200mm	1 pcs.
100307E	Pocket filter ECONOMIC G4 USI type „D“ thickness 7mm 1x8 pockets with frame 1168mm x 598mm x 200mm	1 pcs.
100310E	Pocket filter PREMIUM G4 SAIMA cone type thickness 22mm 1 pocket with frame 415mm x 380mm x 600mm	1 pcs.
100352E	Pocket filter ECONOMIC G4 Blowtherm thickness 7mm 1x10 pockets with frame 1195mm x 595mm x 200mm	1 pcs.
100356	Pocket filter Blowtherm (area) FK 356 1x10 pockets with frame 1195 x 485 x 200mm	1 pcs.

APP 100306



APP 100307



APP 100310



APP 100321



APP 100352



APP 100370



APP 100390



APP 100307E



APP 100310E



APP 100352E



APP 100356



• APP FP 20, APP FP 25, APP FP 28 Floor filters for spray cabins

The APP PAINT STOP green-white floor filtration mat with a G3 filtration class is designed to capture sprayed conventional and water-dilutable paints in spray-painting installations during car manufacturing, in spray-painting and industrial painting cabins for: furniture, windows, machine parts, etc. The progressively mounted dry filter with fibers of 100% fiberglass has the form of a layered, flexible mat. The filter's density rises in the airflow direction. Green color on the air intake side.

➤ ADVANTAGES

- low compressibility guarantees high filter capacity
- progressive structure ensures a balanced distribution of capture paint
- labyrinth structure provides high filtering efficiency
- flammability class DIN 53438-3 (F1) - slow-burning

Parameters	FP 20	FP 25	FP 28
APP NO. / Dimensions	101210 / 0,76 m x 20 mb	101010 / 0,76 m x 25 mb	101410 / 0,76 m x 20 mb
	101220 / 0,86 m x 20 mb	101020 / 0,86 m x 25 mb	101420 / 0,86 m x 20 mb
	101230 / 1,0 m x 20 mb	101030 / 1,0 m x 25 mb	101430 / 1,0 m x 20 mb
	101240 / 1,2 m x 20 mb	101040 - 1,2 m x 25 mb	101440 / 1,2 m x 20 mb
	101290 / 2,0 m x 20 mb		101460 / 1,5 m x 20 mb
Thickness	85-90 mm	70-75 mm	70-75 mm
Capture effectiveness	93-97%	93-97%	95%
Max temp.	180°C	180°C	180°C
Filtration class (EN 779)	G3	G3	G2

FP 20



FP 25



FP 28

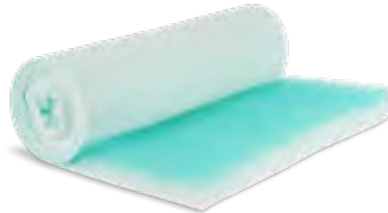

• APP FKW 10 i APP FKB 10 Andreae Filters

APP Andreae filters are made from two layers of cardboard paper, pleated and glued together. They are designed for use in industrial paint-shops during industrial spray-painting of: furniture, windows, machine parts, etc. The labyrinth cardboard filters operate on the principle of inertial separation. Particles heavier than air adhere to the walls, while the airflow continues further uninterrupted. Additionally, "moist" paint particles adhere to the filter walls while the air passes through the labyrinth created from the walls and openings.

➤ ADVANTAGES

- filtering efficiency up to 98,10%, depending on the paint type
- high wet dust capture capacity up to 20 kg/m²
- high temperature resistance up to 180°C

APP NO.	Type	Color	Dimensions	Col. pack.
100843	for conventional paints	brown	h-100 cm, 10 m ²	1 pcs.
100847	for conventional paints	brown	h-90 cm, 10 m ²	1 pcs.
100851	for conventional paints	brown	h-75 cm, 10 m ²	1 pcs.
100844	for conventional paints	white	h-100 cm, 10 m ²	1 pcs.
100848	for conventional paints	white	h-90 cm, 10 m ²	1 pcs.
100852	for conventional paints	white	h-75 cm, 10 m ²	1 pcs.

FKB 10

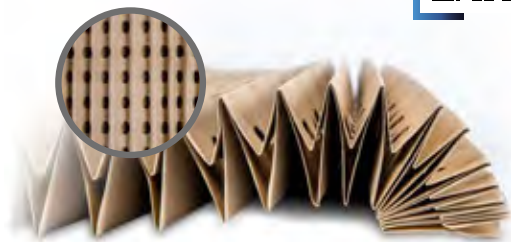

FKW 10





• APP PK 900

High density protective fluid for spray cabins

APP PK 900 is a noncombustible, colorless and odorless, high viscosity fluid with dust absorbing properties.

The product is designed to protect the interior walls of light fittings and windows of spray cabins against accumulation of sprayed paint and eliminate dust particles carried by air movements and electrostatic forces.

➤ ADVANTAGES

- does not alter the light color after applying to light fittings
- depending on the degree of dilution, enables any type of fluid application onto the cabin walls
- forms a viscous, transparent protective coating after application
- water-dilutable and biodegradable
- features a large amount of anti-mold additive



APP NO.	Dimensions
070903	5,0 L

• APP PK 800

Protective fluid for spray cabins

The APP PK 800 is a noncombustible, colorless and odorless, medium viscosity liquid with dust absorbing properties. It provides protection of walls, glass panes and light fittings in spray cabins against painting dry spray and dust circulation.

The fluid forms a viscous, transparent protective coating after application. It is ready for application with a brush, roller or spray gun (2.0-2.5 nozzle). When necessary, the compound can be diluted with water up to 10%.

➤ ADVANTAGES

- thermal resistance: +80°C
- color: colorless - transparent - does not alter the lighting color in the spray cabin
- efficiency: cabin 7 x 4 x 3 m - approx. 7-10 L
- any chosen application method of compound appropriately diluted with water
- forms a viscous, transparent protective coating after application
- easy to wash off using water or water with detergent
- biodegradable

For maximum protection of the cabin's walls, we recommend using the fluid with the APP F Mask foil. It is ready for application with a brush, roller or a spray gun (2.0-2.5 nozzle). When necessary, the compound can be diluted with water up to 10%.



APP NO.	Dimensions
070905	5,0 L

SPRAY-PAINTING

1



Workshop auxiliary
equipment

21-232 SPRAY-PAINTING

- 21-28 Putties and fillers
- 29-36 Base and primers
- 37-46 Top coats
- 47-56 Modular color selection system
- 57-62 Thinners, removers and additives
- 63-67 Repair of plastics
- 69-76 Adhesives and sealants
- 77-84 Car body protection and soundproofing
- 85-96 Abrasives
- 97-106 Masking systems
- 107-118 Polishing
- 119-126 OHS
- 127-132 Fabric filters and spray-painting booth accessories
- 133-154 • Workshop auxiliary equipment**
- 155-170 Various spray-painting products
- 171-178 Spray guns and extruders
- 179-186 Pneumatic grinders
- 187-192 Electric grinders, heat guns and lamps
- 193-198 Work disks
- 199-204 Dust extraction
- 205-208 Radiators
- 209-218 Pneumatics
- 219-222 Spray gun regenerators and washers
- 223-232 Technical sprays

• NTools Premium

Revolving spray-painting stand for elements

NTools Premium is a classic, universal and easy to use revolving spray-painting stand with a rigid and stable structure, made from electrogalvanized steel sections and pipes. Intended for spray painting, as well as grinding and polishing individual car bodywork elements. It enables secure and stable fastening of any bodywork element using universal catches fitted to the technological openings in the body panels of any vehicle. The stand's revolving mechanism with a toothed wheel unlocked with the foot allows to easily rotate the repaired element and lock it in place at any angle. The 52 cm wide wheels allow to freely move the stand with the element around the workshop. The stand features additional grips and accessories which can be ordered separately. The stand's weight is 24 kg. Load capacity – 40 kg.

► STAND ELEMENTS:

- universal catches – 6 pcs.
- universal hanger – 2 pcs.
- catch clamp set – 8 pcs.
- rotary beam – 1 pcs.
- rotary beam extension – 1 pcs.
- spray-gun holder – 1 pcs.
- holder on the bottom beam – 2 pcs.
- transport wheels – 2 pcs.
- frame and rotation lock elements – 5 pcs.

APP NO.	Weight	Dimensions	Load capacity	Diameter of a circle
170102	24 kg	2020 x 810 x 1050 mm	40 kg	52 mm



* Powder coated elements, other galvanized

See the video



• NTools Standard

Revolving spray-painting stand for elements

NTools Standard is a classic, universal and easy to use revolving spray-painting stand with a rigid and stable structure, made from electrogalvanized steel sections and pipes. Intended for spray painting, as well as grinding and polishing individual car bodywork elements. It enables secure and stable fastening of any bodywork element using universal catches fitted to the technological openings in the body panels of any vehicle. The stand's revolving mechanism with a toothed wheel unlocked with the foot allows to easily rotate the repaired element and lock it in place at any angle. The 52 cm wide wheels allow to freely move the stand with the element around the workshop. The stand features additional grips and accessories which can be ordered separately. The stand's weight is 24 kg. Load capacity – 40 kg.

► STAND ELEMENTS:

- universal catches – 6 pcs.
- universal hanger – 2 pcs.
- catch clamp set – 8 pcs.
- rotary beam – 1 pcs.
- rotary beam extension – 1 pcs.
- spray-gun holder – 1 pcs.
- holder on the bottom beam – 2 pcs.
- transport wheels – 2 pcs.
- frame and rotation lock elements – 5 pcs.

APP NO.	Weight	Dimensions	Load capacity	Diameter of a circle
170102E	22 kg	2020 x 810 x 1050 mm	40 kg	52 mm

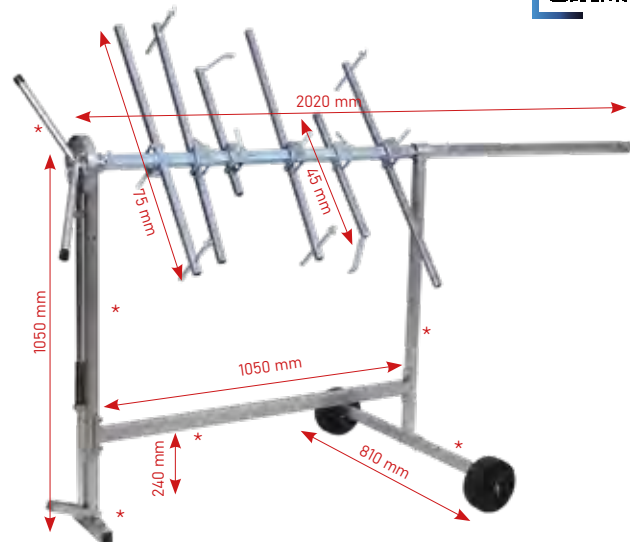

* Powder coated elements, other galvanized

See the video



• NTools DOOR GRIP

Grip for spray-painting doors without removing upholstery

The NTools DOOR GRIP is a grip for performing repairs of car doors without the need to remove upholstery and mounting on a revolving spray-painting stand. The adjustable elements allow to mount nearly any doors of popular car brands using their technological elements, such as lock bolts, hinges and threads of hinge mounting holes. To safely and properly use the grip's capabilities, it is recommended to equip the corresponding revolving stand with additional elements such as a stabilizing beam (APP No. 170102J_ and an extension for the revolving spray-painting stand (APP No. 170102D). The stabilizing beam will prevent the stand from overturning when loaded with a higher weight, while the extension allows to mount longer doors.

APP NO.	Shoulder distance	Grip range
170123	535 mm	225 - 360 mm



zobacz film 



• NTools RIM GRIP

Clamp grip for spray painting car wheel rims

The NTools RIM GRIP is a rotary grip intended for spray-painting steel and aluminum car wheel rims. The grip's first element is a rotating attachment that allows to turn the rim while spray-painting. It features rubber padding that protects the painted element's edges against damage. Inside the attachment is an additional stiffening element in the form of a steel channel bar which increases its strength and durability. The second part is a steel rotary axis with a position lock. The third element is an NTools ZZ clamp for mounting the grip to the beam of a revolving spray-painting stand. The NTools RIM GRIP is a universal grip intended for all types of car wheel rims. The grip is made from steel and is completely zinc coated.

APP NO.	Description
170102F	rotating attachment, functional mounting grip



view video 



• NTools ZUR

Adjustable catch for the revolving spray-painting stand

NTools ZUR is a catch with an adjustable grip intended for mounting elements using technological openings not located on a single plane to the revolving spray-painting stand. The beam of the catch is made from a zinc coated 20 x 20 mm steel section with a wall thickness of 2 mm. It ends with a welded on nut and butterfly bolt for locking the movable rod with the hook and slot holder. The movable rod of the catch is placed in the through hole of the catch beam. The catch beam length is 750 mm. Features an M10 butterfly locking bolt.

➤ ADVANTAGES:

- very high adjustment capabilities after using even one adjustable catch in a set of standard catches
- possibility of working on elements with holes in 3D without initial mechanical stress
- universal application with any clamping holders

APP NO.	Dimensions	Bolt
170102I	790 - 205 mm	features an M10 butterfly locking bolt.



• NTools ZU

Universal catch for the revolving spray-painting stand

NTools ZUR is a universal catch for mounting elements using their technological holes located in a single plane, to a revolving spray-painting stand. The beam of the catch is made from a zinc coated steel section with a wall thickness of 2 mm. It is ended with a perpendicular, rigid rod with a hook and gap holder for mounting the edges of an element. The length of the beam is 750 mm.

➤ ADVANTAGES

- ability to freely configure a set of catches
- very high durability
- universal application with any clamping holders

APP NO.	Description
170102A	the beam of the catch is made from a zinc coated steel section

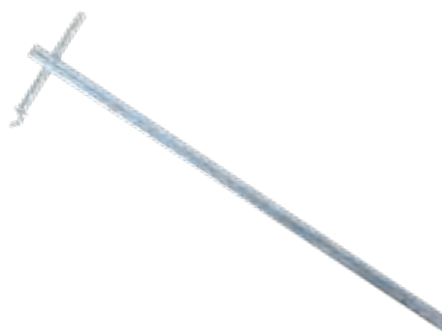

• NTools ZZ

Catch clamp for the revolving spray-painting stand

NTools ZZ is a clamp for mounting universal and adjustable catches, car wheel rim and door spray-painting grips, and holders for small elements to the rotary beam of a spray-painting stand. It is made from galvanized steel. It features a screw clamp with an M10 butterfly screw.

APP NO.	Description
170102B	It features a screw clamp with an M10 butterfly screw.



• NTools WUS

Universal grinding cart

The NTools WUS is a practical and light, universal cart intended for grinding equipment and materials. The cart is designed with the intent of providing the user comfort of work and quick access to all the most frequently used tools all within one workstation.

The NTools WUS features a stable structure with large, rubberized wheels that enable the operator to quickly move the cart along the workshop floor or the preparation area.

APP NO.	Size	Size with wheels
170235	90 x 59 x 160 cm	104 x 98 x 160 cm



view details



• NTools WUP

Universal polishing cart

The NTools WUP is a universal cart intended for storing and transporting polishing equipment and materials. The cart is designed with the intent of providing the user comfort of work and quick access to all the most frequently used tools all within one workstation. The NTools WUS features a stable structure with large, rubberized wheels that enable the operator to quickly move the cart along the workshop floor or the preparation area.

APP NO.	Size	Size with wheels
170236	90 x 59 x 160 cm	104 x 98 x 160 cm



- **NTools BS76, NTools B0, NTools PSO i NTools UDP i NTools PP Wheel**

Beams, extensions, spray-gun and wheel holder for the revolving spray-painting stand

- **NTools BS76**

NTools BS76 is a beam that increases the base stability of revolving spray-painting stands available in the APP offer. The beam increases the support width of the stand and levels out surface unevenness. It is made from a galvanized 30 x 30 mm steel section with a wall thickness of 2 mm and 750 mm in length, with a mounting element compatible with NTools stands.



- **NTools B0**

NTools B0 is a rotary beam for the revolving spray-painting stands featured in APP's offer. The beam is used for mounting universal and adjustable catches, car wheel rim and door spray painting grips, and small element holders using NTools ZZ clamps. It is made from a galvanized 30 x 30 mm steel section with a wall thickness of 2 mm and is 1150 mm in length, with mounting elements compatible with NTools stands.



- **NTools PSO**

NTools PSO is an extension element for the rotary beam of spray-painting stands featured in the APP offer. It is made from a galvanized 30 x 30 mm steel section with a wall thickness of 2 mm and is 750 mm in length, with a connector compatible with NTools stands.



- **NTools UDP**

NTools UDP is a powder-coated steel spray-gun holder made from a 5 mm diameter wire. It is intended for mounting to NTools revolving spray-painting stands available in the APP offer. The set includes bolts, washers and nuts for individual installation.



- **NTools PP Wheel**

The NTools PP Wheel is a wheel made from PP plastic. Its large outer diameter and width enable unhindered movement along the grates of preparation areas and spray-painting cabins. It is part of the standard accessories of NTools revolving spray-painting stands available in the APP offer. Wheel diameter 180 mm. Wheel width 50 mm. Axis opening diameter 12 mm.



APP NO.	Description	Dimensions
170102J	NTools BS76	30 x 30 x 750 mm
170102C	NTools B0	30 x 30 x 1150 mm
170102D	NTools PSO	30 x 30 x 750 mm
170102K	NTools UDP	-
170531	NTools PP Wheel	d180 x 50 mm

• NTools T-Handle

Handle for spray-painting small elements

The NTools T-Handle is a handle for spray-painting small car body elements (mirror frames, side moldings, door handles, etc.). The 460 mm handle consists of a steel pipe with a diameter of 16 mm with attached clamping tongs designed to grip the elements intended for painting. The maximum clamping jaws opening is 37 mm. The handle is intended for use with the NTools MS Stand, NTools Tree Stand and the NTools Premium and Standard revolving spray-painting stands.

APP NO.	Load capacity	Dimensions
170226	3 kg	d16 x 470 mm



view video



• NTools MS Stand

Magnetic stand for spray-painting small elements

The NTools MS Stand is a magnetic stand for spray-painting small and minor car body elements (mirror frames, side moldings, door handles, etc.). The stand consists of two parts, a base and grips. The base is equipped with magnets and a module ending with steel rods. The magnets allow to mount the stand on both horizontal (e.g. bodywork elements – engine cover, roof) and vertical surfaces (e.g. walls inside spray-painting cabins). The second part consists of NTools T-Handle grips (APP No. 170226), which are steel pipes with attached clamping tongs, designed to grip the spray-painted elements. The stands' elements are made entirely from steel and are fully zinc coated.

APP NO.	Height	Distance between the handles
170224	540 mm	0 - 37 mm



view video



• NTools Tree Stand

Stand for spray-painting small elements

The NTools Tree Stand is a stand designed for spray-painting small and minor car bodywork elements (mirror frames, side moldings, door handles, etc.). The stand is made from 30 x 30 mm steel sections with a wall thickness of 2 mm, fully powder-coated, and five galvanized, detachable NTools T-Handle grips (APP no. 170226).

➤ ADVANTAGES

- sturdy and light construction
- multipurpose application
- ease of use
- quick and simple assembly
- saves time and space

APP NO.	Weight	Dimensions	Load capacity
170225	5,5 kg	580 x 520 x 1360 mm	3 kg



view video



• NTools BLK 3

Hood and trunk blocking rod

The NTools BLK 3 is a set for secure and stable blocking of moving elements of the bodywork, such as engine and trunk covers, and doors in the open position with possibility of opening angle adjustment. The tool ensures smooth opening adjustment in a range from 30 to 115 cm. It features stepless locking using a screw with a knob. The set's elements are made from powder-coated* or electrogalvanized steel.

➤ ADVANTAGES

- high adjustment range
- stepless adjustment and lock
- does not require using additional tools
- simple and durable construction
- universal application

APP NO.	Weight	Adjustment range
170115	1,5 kg	30 - 115 mm

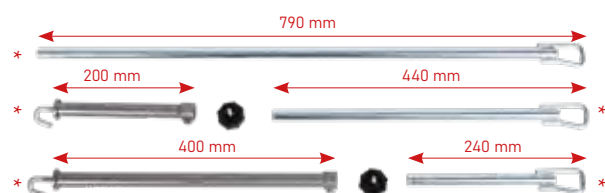

* Powder coated elements, other galvanized

• NTools UNI Stand

Universal spaced stand with rubber holders

NTools UNI Stand is a sturdy with adjustable spacing, with a chain lock, intended for work in the workshop during processing of bodywork elements or preparation of windshields for installation. The electrogalvanized steel tubes with a diameter of 32 mm and thickness of 1.2 mm are secured by a soft cover made from EPE foam which protects the placed element against damage. The stand is equipped with four removable rubber holders / suction cups with a 125 mm diameter, enabling stable placement of an element or a large windshield on the stand.

Stand dimensions: minimum (L x W x H): 1050 x 900 x 750 mm and maximum (L x W x H): 1050 x 480 x 1060 mm.

> ADVANTAGES

- light, sturdy and collapsible construction
- universal application
- adjustable width and height
- easy and quick assembly
- soft protective cover for the placed elements
- removable suction cups

APP NO.	Weight	Dimensions	Load capacity
170150	8 kg	max. 1050 x 480 x 1060 mm	150 kg



• NTools STM-X

X assembly stand

NTools STM X is a universal stand with a strong and stable construction. The stand is intended for spray-painting and processing of various types of bodywork elements, such as bumpers and spoilers. It is made from electrogalvanized 30 x 30 mm steel sections with a wall thickness of 2 mm and a steel tube with a diameter of 38 mm, fully electrogalvanized. The stand features a simple and reliable, toothed adjustment mechanism for changing the arm height and spacing, enabling several working positions. Additional accessories for the stand include two supports that allow to secure a second processed element. The supports enable stable placement of elements and protection against accidental shifting during spray painting. Additional holders are not part of the stand and are sold separately.

APP NO.	Weight	Dimensions	Dimensions the steel sections
170010	8 kg	1270 x 600 mm	30 x 30 mm



view video 



• NTools STM-XU

Grips for the X assembly stand

NTools STM XU are two Fastening grips that enable support of a longer processed element. This solution allows for secure placement of elements and protection against accidental shifting during spray-painting.

APP NO.	Description
170011	The supports feature adjustment and assembly elements compatible with the NTools STM-X stand (App no. 170010). Support length 510 mm.



• NTools Multi Stand Pro

Multifunctional revolving spray-painting stand

The NTools Multi Stand Pro is a multifunctional revolving stand for spray-painting vehicle body elements. It features fully adjustable components ensuring stable mounting of painted elements. It enables height adjustment and change of the element tilt angle during painting. Setting the proper angle ensures more precise and faster spray-painting. The stand is designed for use while painting bumpers, spoilers, fenders, and smaller bodywork elements. The stand's functionality can be expanded by incorporating catches and clamps available separately. The use of the above will allow to mount bodywork elements such as: engine cover or door. Additionally, the stand set also comes with a cover protecting the clamping tongs and packaging of clamping bands used to stably mount the spray-painted elements.

➤ ADVANTAGES

- sturdy and light construction
- multi-purpose application
- quick and easy assembly
- time savings
- large wheels adapted to moving on grates in spray-painting cabins and uneven surfaces

APP NO.	Weight	Dimensions	Load capacity
170230	16 kg	760 x 1230 x 600 mm	20 kg



view video 



• NTools Bumper Car Stand

Stand for bumpers and spoilers

NTools Bumper Car Stand is a universal, mobile stand with a stable and durable construction. Made from powder-coated and electrogalvanized steel profiles. It is used for storing car bumpers and spoilers, securing them against accidental damage. It features 8 arms whose height and spacing can be easily adjusted at will. Each arm features a polyethylene foam cover that protects the stored elements against scratching or damage. The wide and durable wheels ensure the ability to comfortably move the stand around the workshop. The stand can also be used in car body repair and spray-painting shops.

➤ ADVANTAGES

- universal application
- soft protective cover
- adjustable arm spacing
- stable and sturdy construction
- wide wheels

APP NO.	Weight	Dimensions	Load capacity
170119	28 kg	218 x 113 x 118 cm	80 kg



view details



• NTools Bumper Hanger

Hanger for bumpers and bodywork elements

NTools Bumper Hanger is a hanger intended for storing bumpers and other car bodywork elements, such as engine covers, windshields, side moldings, roof rack rails, etc. The hanger features fully adjustable arms. It is made from 30 x 30 mm and 25 x 25 mm steel profiles with a wall thickness of 2 mm, entirely. Powder coated. The horizontal arms feature foam covers that protect the stored bodywork elements against damage. Using the hanger optimizes the storage space by utilizing walls available in almost any car body repair, spray-painting and mechanical workshop. The set features a mounting kit: expansion plugs, washers and masking frames. The length of the 8 arms is 840 mm. The length of two vertical support elements is 760 mm.

➤ ADVANTAGES

- light and sturdy construction
- multipurpose application
- easy and quick assembly
- additional protection measures in the form of foam covers
- adjustable spacing depending on the user's requirements
- long arms

APP NO.	Weight	Dimensions	Load capacity
170220	10,8 kg	840 x 760 mm	the total load capacity is 60 kg



view video 



• NTools MS

Mobile element stand with Height and length adjustment

NTools MS is a mobile, universal stand designed for use in spray-painting, bodywork repair and mechanical workshops, production halls, or carpentry workshops. The stand features two rubber spans with a fixed width of 870 mm, width adjustment in a range from 150 to 1250 mm and height adjustment from 880 to 1280 mm. These features allow to adapt the stand's size to the dimensions of the element being worked on.

> ADVANTAGES

- large adjustment range
- mobile with large, rubberized, pivoting wheels with a brake
- convenient transport
- takes up little space after folding

APP NO.	Weight	Dimensions	Load capacity
170508	16,5 kg	870 x 150 - 1250 x 880 - 1280 mm	120 kg



view video 



• NTools CE Trolley

Auxiliary trolley for bodywork elements

NTools CE Trolley is an auxiliary trolley for storing bodywork elements. It allows to store the engine cover, trunk cover, lights, bumpers, upholstery elements, and other parts disassembled during vehicle repairs. The trolley is equipped with 4 large, turning wheels, including two with brakes. The wheel size allows for free movement along uneven surfaces on the floor of the workshop. The NTools CE Trolley features two fixed shelves and two bins with an adjustable position for storing smaller and lighter elements.

> ADVANTAGES

- modular construction
- broad application
- high mobility
- easy and quick assembly
- secured sharp edges

APP NO.	Weight	Dimensions	Load capacity
170555	41 kg	850 x 600 x 2000 mm	150 kg



view video 



• NTools CE Trolley Mat

CE Trolley mat set

The mat set for the NTools EC Trolley auxiliary bodywork element trolley is made from general purpose, flexible, rubber mats. They are characterized by excellent resistance to abrasion and damage, such as tearing or puncturing. The mats have anti-slip and noise dampening properties, and are waterproof. They secure bodywork elements against damage.

> ADVANTAGES

- high quality rubber
- water-proof and anti-slip surface
- highly flexible
- ensures cushioning
- secures bodywork elements against damage

APP NO.	Thickness	Dimensions	Load capacity
170559	3 mm	850 mm x 540 mm	150 kg



• NTools Tire Stand Max, Normal i Mini

Mobile tire storage stands

The NTools Tire Stand is a line of mobile stands for storing car tires. They feature light structures with a sturdy frame and come with large, rubberized wheels, including 2 with brakes, for easy movement around the service station, workshop or garage. Thanks to its mobility and functionality, the NTools Tire Stand reduces the user's need to lift and carry around the tires.

➤ ADVANTAGES

- sturdy and light construction
- high mobility
- allows to maintain order in the storage area
- convenient tire storage
- easy operation

APP NO.	Weight	Load capacity	Dimensions
170254	22,5 kg	max. 210 kg	1180 x 560 x 1960 mm
170253	15,5 kg	max. 140 kg	1180 x 560 x 1200 mm
170252	8,5 kg	max. 70 kg	1180 x 560 x 410 mm



• NTools PANEL CART

Cart for storing car body panels

NTools PANEL CART is a mobile cart with a sturdy structure intended for storing windshields, doors, hoods and trunk covers, roof linings, roofs, and other car body panels. High mobility is provided by 4 turning wheels, 2 of which feature brakes. The cart has 6 pairs of arms mounted on the frame thanks to clamps with a knob. The NTools PANEL CART enables storage of up to 5 elements at the same time.

If needed, there is a possibility to adjust the width of the frame in a range of 70-100 cm, as well as the arm spacing. To exclude the possibility of damaging the stored elements, sharp edges have been secured by masking frames, and the arms and frame of the cart additionally feature a soft and elastic cover. The NTools PANEL CART is designed for use in car bodywork painting and repair shops, detailing shops, and all kinds of craftsman workshops.

➤ ADVANTAGES

- sturdy and light construction
- multipurpose application
- simple operation
- quick and easy assembly
- saves time and space

APP NO.	Weight	Dimensions	Load capacity
170250	20 kg	1150 x 700-1000 x 800 mm	80 kg





• NTools ZMS Standard i Deluxe

Grinding material sets

The NTools ZMS Standard sets are a collection of essential materials and equipment for use in car body painting workshops. The sets are configured to facilitate all kinds of grinding works. All the tools are arranged on a light and agile NTools WUS cart that focuses all components of the set in one place. Its mobility and versatility improves comfort of work of the operator and allows to maintain order and tidiness at the workstation. The NTools ZMS Deluxe is an expanded version of the Standard set with a larger number of products .



NO.	170241	NTools ZMS Standard	Grinding material set	Qty. in the set
-----	--------	---------------------	-----------------------	-----------------

Products included in the system:

1	06Z210	APP WS 222	APP WS 222 Abrasive fabric, sheet, Medium grain, Red 150 x 230 mm pack (10 pcs.)	1 pcs.
2	06Z220	APP WS 222	APP WS 222 Abrasive fabric, sheet, Fine grain, Grey 150 x 230 mm pack (10 pcs.)	1 pcs.
3	081210	APP PM 07	Matting paste 1 kg	1 pcs.
4	090413	APP Standard CT	Two-layer technical cleaning cloth white 244 mb	1 pcs.
5	135050	Ntools RS 15050	Pneumatic grinder stroke 5,0 mm 0-12000 RPM disk 5/16	1 pcs.
6	140020	Ntools VC 50EP	Dust extractor with automatic electric-pneumatic on-switch 1400W	1 pcs.
7	150216	APP KSP SET	Grinding blocks – promotional set A,B,C,D,E+2 A+C blocks free	1 pcs.
8	150251	APP KS BLOCK	Grinding block C, Velcro d150	1 pcs.
9	170235	Ntools WUS	Universal grinding cart	1 pcs.
10	250050	APP Dry Coat	Testing powder black set 100g	1 pcs.
11	40HMF080	Ntools HMF 7	Abrasive disk 14+1 holes yellow P80 d150 pack (50 pcs.)	1 pcs.
12	40HMF120	Ntools HMF 7	Abrasive disk 14+1 holes yellow P120 d150 pack (100 pcs.)	1 pcs.
13	40HMF150	Ntools HMF 7	Abrasive disk 14+1 holes yellow P150 d150 pack (100 pcs.)	1 pcs.
14	40HMF180	Ntools HMF 7	Abrasive disk 14+1 holes yellow P180 d150 pack (100 pcs.)	1 pcs.
15	40HMF240	Ntools HMF 7	Abrasive disk 14+1 holes yellow P240 d150 pack (100 pcs.)	1 pcs.
16	40HMF320	Ntools HMF 7	Abrasive disk 14+1 holes yellow P320 d150 pack (100 pcs.)	1 pcs.
17	40HMF400	Ntools HMF 7	Abrasive disk 14+1 holes yellow P400 d150 pack (100 pcs.)	1 pcs.
18	40RG400	APP PS G	Sandpaper on a sponge pad, in a roll yellow P400 115 mm x 25 m	1 pcs.
19	40RG600	APP PS G	Sandpaper on a sponge pad, in a roll yellow P600 115 mm x 25 m	1 pcs.
20	40W120	APP W115	Abrasive web, without holes and Velcro brown P120 115 mm x 280 mm pack (100 pcs.)	1 pcs.
21	40W240	APP W115	Abrasive web, without holes and Velcro brown P240 115 mm x 280 mm pack (100 pcs.)	1 pcs.

NO.	170242	NTools ZMS Deluxe	Grinding material set	Qty. in the set
-----	--------	-------------------	-----------------------	-----------------

Products included in the system:

1	030150	APP W 900	Cleaner for silicone removal, normal 1,0L	1 pcs.
2	06PP0003	APP PMP	Premium soft pad with micro-Velcro 14+1 holes thickness 6mm d150	1 pcs.
3	06Z210	APP WS 222	APP WS 222 Abrasive fabric, sheet, Medium grain, Red 150 x 230 mm pack (10 pcs.)	1 pcs.
4	06Z220	APP WS 222	APP WS 222 Abrasive fabric, sheet, Fine grain, Grey 150 x 230 mm pack (10 pcs.)	1 pcs.
5	081210	APP PM 07	Matting paste 1kg	1 pcs.
6	090413	APP Standard CT	Two-layer technical cleaning cloth white 244mb	1 pcs.
7	090639	APP RN 100 STANDARD	Disposable nitrile gloves CE indigo XL pack (100pcs)	1 pcs.
8	090806	NTools RRR 12C	Nylon-polyurethane work gloves, black, XL, pack. 12par	1 pcs.
9	135025	NTools RS 15025	Pneumatic grinder stroke 2,5mm 0-12000 RPM disk 5/16	1 pcs.
10	135050	NTools RS 15050	Pneumatic grinder stroke 5,0mm 0-12000 RPM disk 5/16	1 pcs.
11	135080	NTools RS 15080	Pneumatic grinder stroke 8,0mm 0-12000 RPM disk 5/16	1 pcs.
12	140020	NTools VC 50EP	Dust extractor with automatic electric-pneumatic on-switch 1400W	1 pcs.
13	150216	APP KSP SET	Grinding blocks – promotional set A,B,C,D,E+2 A+C blocks free	1 pcs.
14	150251	APP KS BLOCK	Grinding block C, Velcro d150	1 pcs.
15	150561	NTools PS 150	Spacer for work disk, Velcro J-Hook, thickness 0,3mm, 50 holes (1pcs.) 50 holes d150	1 pcs.
16	170235	NTools WUS	Universal grinding cart	1 pcs.
17	250050	APP Dry Coat	Testing powder black 100g	1 pcs.
18	251100	APP SZP 1L	Sprayer with pump for cleaners 1,0L	1 pcs.
19	388016	NTools DP PEN	Air purging nozzle	1 pcs.
20	389033	NTools AH 10	Antistatic air duct 8x15 with connectors red 10m	1 pcs.
21	40HMF080	NTools HMF 7	Abrasive disk 14+1 holes yellow P80 d150 pack (50pcs)	1 pcs.
22	40HMF120	NTools HMF 7	NTools HMF 7 - Abrasive disk 14+1 holes yellow P120 d150 pack (100 pcs.)	1 pcs.
23	40HMF150	NTools HMF 7	NTools HMF 7 - Abrasive disk 14+1 holes yellow P150 d150 pack (100 pcs.)	1 pcs.
24	40HMF180	NTools HMF 7	NTools HMF 7 - Abrasive disk 14+1 holes yellow P180 d150 pack (100 pcs.)	1 pcs.
25	40HMF240	NTools HMF 7	NTools HMF 7 - Abrasive disk 14+1 holes yellow P240 d150 pack (100 pcs.)	1 pcs.
26	40HMF320	NTools HMF 7	NTools HMF 7 - Abrasive disk 14+1 holes yellow P320 d150 pack (100 pcs.)	1 pcs.
27	40HMF400	NTools HMF 7	NTools HMF 7 - Abrasive disk 14+1 holes yellow P400 d150 pack (100 pcs.)	1 pcs.
28	40RG320	APP PS G	Sandpaper on a sponge pad, in a roll yellow P320 115 mm x 25 m	1 pcs.
29	40RG400	APP PS G	Sandpaper on a sponge pad, in a roll yellow P400 115 mm x 25 m	1 pcs.
30	40RG600	APP PS G	Sandpaper on a sponge pad, in a roll yellow P600 115 mm x 25 m	1 pcs.
31	40W120	APP W115	Abrasive web, without holes and Velcro brown P120 115mm x 280mm pack (100 pcs.)	1 pcs.
32	40W240	APP W115	Abrasive web, without holes and Velcro brown P240 115mm x 280mm pack (100 pcs.)	1 pcs.

• NTools ZMP Standard i Deluxe Polishing material sets

NTools ZMP Standard is a set of essential materials and equipment needed for polishing. Thanks to properly chosen products, polishing even the most neglected surfaces becomes very simple. All the tools are arranged on a light and agile NTools WUP cart which gathers all of the set's components in one place. The sets are designed for use in one place. The sets are intended for use in car body spray-painting and repair shops, and detailing studios. Mobility and versatility improves the user's work comfort, allowing to maintain order and tidiness at the workstation. The NTools ZMP Deluxe is an expanded version of the Standard set with a larger number of products.



APP 170243



APP 170244



No.	170243	NTools ZMP Standard	Polishing materials set	Qty. in the set
1	080202	APP GP 150 M	Smooth polishing pad h50 - M14 universal orange d150	1 pcs.
2	080302	APP GP 150 M	Smooth polishing pad h50 - M14 black soft d150	1 pcs.
3	080402	APP GP 150 M	Smooth polishing pad h50 - M14 yellow universal d150	1 pcs.
4	080649	APP MF Cloth	Microfiber dust cloth navy blue 40cm x 40cm pack (3pcs.)	1 pcs.
5	081350	APP P1500 Fast Cut & FINISH	Multi-purpose polishing paste 1,0kg	1 pcs.
6	090413	APP Standard CT	Two-layer technical cleaning cloth white 244mb	1 pcs.
7	126002	NTools RP 1180E	Electrical polisher with smooth rotation adjustment 1400W 500-3000 RPM 3,20kg	1 pcs.
8	150102	APP KSK	Cork grinding block 115mm x 60mm x 25mm	1 pcs.
9	150409	APP KA PSK	Universal aluminum block for manual grinding of inclusions d30	1 pcs.
10	170236	NTools WUP	Universal polishing cart	1 pcs.
11	210910	APP Finish Test Spray	Spray for testing the correct polishing of a surface foam 400ml	1 pcs.
12	250004	APP SDW	Cutter for paint defect removal	1 pcs.
13	40MW2000	APP M991	Waterproof sandpaper P2000 blue 230mm x 280mm pack (50 pcs.)	1 pcs.
14	40MX1500	APP MX	Waterproof abrasive pads on adhesive P1500 blue d35 pack (12 pcs.)	1 pcs.
15	40MX2000	APP MX	Waterproof abrasive pads on adhesive P2000 blue d35 pack (12 pcs.)	1 pcs.
16	40MX2500	APP MX	Waterproof abrasive pads on adhesive P2500 blue d35 pack (12 pcs.)	1 pcs.
17		NTools FP 1	Polishing apron black L/XL	1 pcs.
18	GRATIS	Czapka z daszkiem NTools	NTools cap	1 pcs.
19		Pad Box	Polishing pad box	1 pcs.

No.	170244	NTools ZMP Deluxe	Polishing materials set	Qty. in the set
1	06PM0001	NTools PMG06 MR	Micro-rubber pad with micro-Velcro 14+1 holes thickness 6mm d150	1 pcs.
2	080008	APP Wool 1 Step Fast Cut & FINISH	Polishing wool - Velcro white d135	1 pcs.
3	080014	APP QUARTZ Q804 i Q805	Polishing pad set h30 white/orange d160 2pcs.	1 pcs.
4	080015	APP QUARTZ Q804 i Q805	Polishing pad set h30 white/orange d145 2pcs.	1 pcs.
5	080019	APP QUARTZ Q811	Polishing pad - Velcro white h25 d135	1 pcs.
6	080202	APP GP 150 M	Smooth polishing pad h50 - M14 universal orange d150	1 pcs.
7	080302	APP GP 150 M	Smooth polishing pad h50 - M14 black soft d150	1 pcs.
8	080401	APP GP 150 PR	Ribbed polishing pad h25 - Velcro blue universal d150	1 pcs.
9	080402	APP GP 150 M	Smooth polishing pad h50 - M14 yellow universal d150	1 pcs.
10	080503	APP GP 180 PR	Ribbed polishing pad h25 - Velcro black soft d180	1 pcs.
11	080646	APP QUARTZ Q806	Microfiber dust cloth navy blue 40cm x 40cm pack (1 pcs.)	1 pcs.
12	080649	APP MF Cloth	Microfiber dust cloth navy blue 40cm x 40cm pack (3 pcs.)	1 pcs.
13	080802	APP CLAY BAR	Plastic mass for smooth surface cleaning - clay red aggressive 200g	1 pcs.
14	080803	APP CLAY BAR	Plastic mass for smooth surface cleaning - clay blue gentle 200g	1 pcs.
15	081321	APP QUARTZ Q803	Carnauba wax 300g	1 pcs.
16	081350	APP P1500 Fast Cut & FINISH	Multi-purpose polishing paste 1,0kg	1 pcs.
17	081370	APP QUARTZ Q801	Coarse grain polishing paste white 1,0kg	1 pcs.
18	081371	APP QUARTZ Q802	Multi-functional polishing paste black 1,0kg	1 pcs.
19	090413	APP Standard CT	Two-layer technical cleaning cloth white 244mb	1 pcs.
20	090802	NTools RRN 12B	Nylon-polyurethane work gloves, white, XL, pack. 12 par	1 pcs.
21	126010	NTools RP 150E Pro	Professional electrical rotary polisher 1000W 800-3300 RPM 2,5kg	1 pcs.
22	126004	NTools DAP II 15E	Dual Action electrical polisher with a stroke of 15 mm stroke 15mm 2200-5000 RPM 2,3kg	1 pcs.
23	135025	NTools RS 15025	Pneumatic grinder stroke 2,5mm 0-12000 RPM 5/16 disk	1 pcs.
24	139210N	NTools PSM30	Pneumatic grinder for small surfaces	1 pcs.
25	150102	APP KSK	Cork grinding block 115mm x 60mm x 25mm	1 pcs.
26	150409	APP KA PSK	Universal aluminum block for manual grinding of inclusions d30	1 pcs.
27	150521	NTools WP 125	Work disk for Velcro mounted pads, M14, d125	1 pcs.
28	150522	NTools WP 150	Work disk for Velcro mounted pads, M14, d150 M14 d150	1 pcs.
29	170236	NTools WUP	Universal polishing cart	1 pcs.
30	171110	NTools Colour Check 4500	Paint coat inspection lamp 5W COB Led CRI>95 310g	1 pcs.
31	210910	APP Finish Test Spray	Spray for testing the correct polishing of a surface foam 400ml	1 pcs.
32	220217	APP GB SB	Sponge for applying care and protection compounds 100mm x 55mm	1 pcs.
33	250003	APP NDZ	Paint tear removal knife (cutter)	1 pcs.
34	250004	APP SDW	Cutter for paint defect removal	1 pcs.
35	250319	NTools Ekspander	Rubber line with hooks 80cm x 8mm	1 pcs.
36	40FMQ2000	APP QUARTZ Q40	Abrasive disk on film 14+1 holes P2000 grey d150 pack (100 pcs.)	1 pcs.
37	40MW2000	APP M991	Waterproof sandpaper P2000 blue 230mm x 280mm pack (50 pcs.)	1 pcs.
38	40MW2500	APP M991	Waterproof sandpaper P2500 blue 230mm x 280mm pack (50 pcs.)	1 pcs.
39	40MX1500	APP MX	Waterproof abrasive pads on adhesive P1500 blue d35 pack (12 pcs.)	1 pcs.
40	40MX2000	APP MX	Waterproof abrasive pads on adhesive P2000 blue d35 pack (12 pcs.)	1 pcs.
41	40MX2500	APP MX	Waterproof abrasive pads on adhesive P2500 blue d35 pack (12 pcs.)	1 pcs.
42		NTools FP 1	Polishing apron black L/XL	1 pcs.
43	GRATIS	Czapka z daszkiem NTools	NTools cap	1 pcs.
44		Pad Box	Polishing pad box	1 pcs.

• NTools SPM 5 i SPM 3

Horizontal stands for 5 or 3 rolls of masking paper

NTools SPM 5 and SPM 3 are horizontal stands designed for five rolls of masking paper with dimensions from 30 cm to 120 for SPM 5 and three rolls with dimensions from 30 cm to 90 cm for SPM3. The stands feature adjustable Fastenings for mounting the masking paper rolls in various widths and a diameter up to 25 cm. The roll Fastenings are equipped with an arm with a rotating roll for mounting adhesive tape and a spring with a pad for applying pressure and stable placement of the paper roll. Each level features cutting bars with fine and sharp teeth. The stand's construction enables simultaneous unrolling of a section of paper and taping the paper edges with adhesive tape, and easy cutting on the cutting bar. The wheels make it possible to easily move the stands around the spray shpack. The stands are designed for use in spray shops for works involving masking of car body elements or other items. They come with plastic cylinders for mounting the masking paper rolls.

APP NO.	Stand weight	Dimensions	Wheel diameter
170204	32 kg	1500 x 620 x 1330 mm	52 mm
170202	23 kg	1200 x 620 x 1140 mm	52 mm



APP 170204



APP 170202



• NTools SPMU 3

Diagonal stand for 3 rolls of masking paper

NTools SPMU 3 is a diagonal stand designed for three rolls of masking paper with dimensions from 30 cm to 90 cm. The stand features adjustable masking paper roll mounting Fastenings with different widths and diameter up to 25 cm. The roll Fastenings are equipped with an arm with a rotating roll for mounting adhesive tape and a spring with a pad for applying pressure and stable placement of the paper roll. Each level features cutting bars with fine and sharp teeth. The diagonal stand features additional arms with rotating rolls for mounting adhesive tape and features rollers pressing the tape to the paper while unrolling. The stand's construction enables simultaneous unrolling of a section of paper and taping the paper edges with adhesive tape, and easy cutting on the cutting bar. The 52 mm wide wheels make it possible to easily move the stands around the spray shpack. The stands are designed for use in spray shops for works involving masking of car body elements or other items. They come with plastic cylinders for mounting the masking paper rolls.

APP NO.	Stand weight	Dimensions	Wheel diameter
170206	12 kg	1500 x 620 x 1100 mm	52 mm



• NTools ADG75

Tube adapter d75

An essential rotating insert for attaching at the ends of a masking paper or foil roll tube when mounting on a stand.

APP NO.	Description
070460	the adapter has an outer diameter of 75 mm and a central opening with a diameter of 23 mm.



• NTools Foil Cart

2in1 masking foil cart

NTools Foil Cart is a cart designed for masking foil in rolls with dimensions up to 1000 x 240 mm and/or in a cardboard package. The construction enables a single person to secure the bodywork of a car for spray painting or performing other workshop activities. The lower part of the cart features Fastenings for storing and direct dispensation of foil from the cardboard package. The middle part features a bar for mounting a roll of foil. The cutting bar guide located in its upper part allows to evenly and quickly cut any given length of foil. The NTools Foil Cart is designed to keep the foil cutter by the cart so that it is always available for use.

Foil Cart Stand dimensions: L. 1560 mm, W. 670 mm, H. 800 mm.
Stand weight: 13 kg

> ADVANTAGES

- compatible with foil in a roll and in a cardboard package
- can be handled by a single person
- even and quick cutting of any length of foil
- magnetic hanger for a foil cutter or knife
- large and wide wheels adapted for moving on grates in the preparation area

APP NO.	Weight	Dimensions	Load capacity
170207	13 kg	1560 x 670 x 800 mm	40 kg



• APP F Cut

Masking foil cutter

APP F Cut is a cutter for masking foil. It allows the user to cut the required length of foil quickly and with a smooth edge, and precisely cut away an unnecessary fragment of a cover from the repaired element's surface.

> ADVANTAGES

- simple and ergonomic construction
- optimal blade mounting angle
- safe and flexible cutting edge guide

APP NO.	Sales unit	Col. pack.
170199	1 pcs.	50 pcs.
170200	pack. 10 pcs.	5 pcs.



• NTools SG GRIP

Spray-gun holder

NTools SG GRIP is a spray-gun holder. It is intended for work with four spray-guns simultaneously. Its upper part features a rotating Fastening for supporting the spray-painting strainer when filling the container with a lacquer or base. The middle section features four rubberized and properly profiled Fastenings for mounting spray guns by their tanks. The bottom section is a base with openings for permanently fixing the holder to, e.g. a table pack.

> ADVANTAGES

- ability to work with 4 spray-guns simultaneously
- rotating Fastening for a spray-painting strainer
- rubberized Fastenings for spray-guns
- sturdy structure
- stable base

APP NO.	Base dimension	Dimensions
170228	15 x 15 mm	400 x 290 mm



view video 



- **NTools SDP**
Spray-gun stand

NTools SDP is a single, standalone stand that allows pouring paints and lacquers to the tank of a spray-gun and facilitates the spray-gun's storage in the workshop. The well-thought-out, simple construction secures the spray-gun head against mechanical damage. The rubberized holding Fastening padding prevents damage to the tanks of spray-guns.

APP NO.	Dimensions
170107	300 x 260 x 170 mm



- **NTools WDP**
Spray-gun hanger

NTools WDP is a simple hanger allowing to mount a spray-gun. The screw holes allow the hanger to be fastened to a wall or vertical element. The well-thought-out, simple construction secures the spray-gun head against mechanical damage.

APP NO.	Description
170106	The rubberized holding Fastening padding prevents damage to the tanks of spray-guns.



- **NTools WMAG**
Magnetic spray-gun hanger

NTools WMAG is a magnetic hanger that allows to suspend and store two spray-guns.

APP NO.	Description
170110	The magnets on the back wall of the hanger allow it to be mounted anywhere inside the spray-painting cabin or spray-gun washing station.



- **NTools Paper Stand**
Stand for paper towels

The NTools Paper Stand is a stand designed to hold rolls of paper towels. It enables easy dispensation of the cleaning paper and replacement of a used roll. The stand facilitates work organization and maintenance of cleanliness in the workshop. Stand dimensions: H. 1000 mm, W. 440 mm, L. 600 mm. Maximum paper roll width: 330 mm

APP NO.	Maximum paper roll width	Stand dimensions
170108	33 cm	1000 x 440 x 600 mm



- **NTools 3S**
Three-shelf workshop trolley

NTools 3C is a workshop trolley with a very durable, steel construction designed for storing and transporting tools and various workshop equipment. It features three deep shelves with embossing, powder-coated. It is equipped with 4 durable, rubberized wheels, including two turning ones with a brake. The trolley features a push handle made from aluminum.

APP NO.	Weight	Dimensions	Load capacity
170541	22 kg	800 x 390 x 835 mm	200 kg



• NTools MG3

Rubber mats for the three-shelf trolley

Rubber mats for the three-shelf workshop trolley are made from rubber, and corrugated along their entire length. The mats are intended to secure tools and materials placed on the trolley's shelves against shifting and damage during transport. The set consists of 3 mats with dimensions of 375 x 700 cm. The mats are designed for the NTools 3S three-shelf workshop trolley, APP No. 170541.

APP NO.	Color / Option	Dimensions	Sales unit
170541MG	black	375 x 700 mm	kpl. 3 pcs.



• APP 3S Heavy

Three-shelf workshop trolley

NTools 3S Heavy is a sturdy and large workshop trolley with a very durable construction. Intended for use in car body repair and spray painting or carpentry workshops for storage and transport of tools and various workshop equipment. Features 3 deep and spacious shelves.

➤ ADVANTAGES

- sturdy construction
- universal application
- high load capacity
- large and spacious shelves
- rubber wheels with brakes

APP NO.	Weight	Dimensions	Load capacity
170539	28 kg	1000 mm x 475 mm x 855 mm	350 kg



• NTools MSW 50

Mobile workshop seat with height adjustment

NTools MSW 50 is a mobile workshop stool with pneumatic height adjustment and a rotating seat. The metal construction is mounted on 5 swivel wheels, and the area under the seat features spaces for all types of wrenches and other tools. The MSW 50 features soft sponge padding that cushions pressure when sitting. The seat is useful in any car body repair and spray-painting shop or mechanical workshop, can be used during all kinds of shop works and activities. The stool facilitates work on the lower sections of a car.

APP NO.	Weight	Height range	Load capacity	Seat diameter
170505	5,3 kg	38-50 cm	100 kg	30 cm



• NTools MSWS

Mobile workshop seat with a drawer

The NTools MSWS is a mobile workshop seat with a drawer. The metal frame mounted on 4 pivoting wheels is completely protected with an anti-corrosive paint coat. Under the seat is a sliding drawer intended for small workshop accessories. The section at the base features a shelf for all kinds of tools.

➤ ADVANTAGES

- soft, upholstered seat
- sliding drawer on guides
- strong metal frame
- handy shelf for accessories
- durable, pivoting wheels

APP NO.	Weight	Dimensions	Load capacity
170506	5,9 kg	440 x 360 x 360 mm	100 kg



view video



• NTools Coin Floor Mat

Anti-slip rubber floor mat

NTools Coin Floor Mat is an elastic, rubber mat designed for general purpose use. The floor mat is characterized by excellent resistance to abrasion and mechanical damage. It features anti-slip and noise-dampening properties, and is waterproof. The NTools Coin Floor Mat combines very high breaking strength and resistance to tearing with high elasticity which is maintained at low temperatures. It is also highly resistant to organic and inorganic acids, alcohols, etc.

➤ ADVANTAGES

- high quality rubber
- waterproof and anti-slip
- very flexible
- protects against dirt
- resistant to the effects of oils and grease
- resistant to adverse weather effects

APP NO.	Roll dimensions	Thickness	Thermal resistance
250325	120 x 25 cm	3 mm	-15°C +75°C



view video



• NTools M TABLE

Mobile workshop table with a bag rim and cleaning towel dispenser

NTools M TABLE is a sturdy, mobile table designed primarily for light workshop activities. High mobility is ensured by 4 pivoting wheels additionally equipped with brakes. The table features a laminated work top made from a furniture board, additionally secured with a rubber mat. It also allows to mount a technical cleaning paper and waste bag. The NTools M TABLE is intended for use in car body repair and paint-shops, and all kinds of crafting workshops.

➤ ADVANTAGES

- cleaning paper holder with cutting bar
- waste bag rim
- d125 rubberized wheels with brakes
- sturdy and light frame
- multipurpose application

APP NO.	Cart weight	Dimensions	Load capacity
170503	38 kg	1170 x 750 x 930 mm	100 kg



view video



• NTools OW290

Waste bag rim with lever operated lid

NTools OW290 is a rim with a lever operated lid for fastening a waste bag. Thanks to the special construction of the rim mounting module, there is a possibility of folding and unfolding it, which significantly limits the space it takes up. The NTools OW290 is fully made from black powder-coated steel. It is recommended to mount the product on the workshop wall, table or shelf rack in the workshop, and in any other available location. The rim's inner diameter is 290 mm. Weight 0,9 kg.

APP NO.	Dimensions	Weight
170504	d290	0,9 kg



• NTools ST LAK

Spray-painting table with fume extraction

The spray-painting table constitutes essential spray-shop equipment. It guarantees efficient and clean performance of spray-painting works. Product specifications: fume extraction, table top dimensions 560 x 1180 mm, made from stainless steel; table top height 960 mm, washing and cleaning tank capacity: The table features a compressed air connection, three spray-gun holding Fastenings, a spray-gun cleaning chamber with a grate preventing the loss of small elements, a drip drier, a drain connection facilitating replacement of dirty solvent, a through shelf for keeping spray-painting materials.

APP NO.	Dimensions	Power
170501	560 x 1180 x 960 mm	5 -6 bar



• NTools HMF 7 TAB

Abrasive disk set board

The HMF7 System board is an efficient tool for organizing work at a garage. The steel board can be used both as a handy storage space for abrasive disks (whole boxes), as well as a hanger for individual disks without boxes. The HMF7 System board features information concerning the division of machines in terms of stroke and disks in terms of gradation. The clear chart shows how to work faster and more accurately using NTools equipment. The functional HMF7 System board is available in a version for hanging on the workshop wall. The board comes with an instruction and accessories required to mount the board (screws, expansion plugs, abrasive disk holders)

APP NO.	Option	Dimensions	Installation
40HMF7TAB	HMF 7 System	550 x 870 x 18 mm	ekspansion plug



• NTools KS TAB

Abrasive disk board with Fastenings for mounting 3 fi 150 grinders

NTools KS TAB is a universal board for organizing a workstation with abrasive disks with holes in the NT/APP series. The steel board can be used both as a handy storage space for boxed abrasive disks, as well as a hanger for individual disks without boxes. Additionally, the board features a steel Fastening for mounting 3 grinders with 150 mm work disks.

➤ ADVANTAGES

- efficient tool for organizing and tidying work at a garage
- nine spaces for boxes or hangers for abrasive disks
- allows control of abrasive disk wear
- features the ability to mount three grinders

APP NO.	Dimensions	Installation
40KSTAB	570 x 1060 x 17 mm	ekspansion plug



• NTools U3

Fastening for mounting 3 grinders with 150 mm work disks

NTools U3 is a powder-coated, steel Fastening designed for hanging three grinders with a work disk diameter of up to 150 mm. The Fastening can be mounted onto an HMF TAB abrasive board and the universal KS TAB board, or directly on the wall using plugs and screws. It is an organizer that helps to tidy the workstation and secure grinders against accidentally falling on the concrete workshop floor.

➤ ADVANTAGES

- universal application
- easy installation

APP NO.	Color	Dimensions	Installation
170105	black	570 mm x 176 mm x 29 mm	ekspansion plug



• NTools MS TAB

Grinding material organizing board

The NTools MS TAB is an organizer designed for storing grinding materials. The set includes two dispensers for grinding fabrics or sandpaper in rolls, and a shelf for storing various grinding articles. The board, dispensers and shelf are made from fully powder-coated steel, colored black. The NTools MS TAB organizer comes with an instruction manual and accessories required to mount the board on the workshop wall (screws, expansion plugs).

APP NO.	Description	Dimensions	Installation
170705	2 dispensers, 1 shelf	550 x 870 x 18 mm	ekspansjon plug



view video



• NTools TPH

Hanger for paper cleaners and towels

This module is designed to expand the possibilities of NTools series organizing boards, giving them additional functionalities. The hanger is used as a dispenser for technical cleaning cloths and paper towels. Dispensation is facilitated by a cutting bar that allows to tear off a specific length of the cleaning paper. NTools TPH can be mounted to a wall, e.g. in a workshop or garage. The hanger is made from fully black powder-coated steel. The set additionally features expansion plugs for individual wall installation.

➤ ADVANTAGES

- low weight
- simple installation
- easy operation
- universal size
- sturdy construction

APP NO.	Dimensions	Thickness of the wall
170117	270 x 310 x 110 mm	1,5 mm

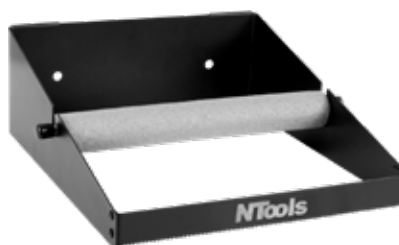

view video



• NTools MS TAB P

Grinding material shelf for NTools boards

The NTools MS TAB P is a shelf intended for storing grinding materials. It is made entirely of 1.0 mm thick steel, fully powder-coated black. The shelf features Fastenings for mounting on NTools series organizing boards.

APP NO.	Weight	Dimensions
170706	0,9 kg	260 x 110 x 180 mm



view video



• NTools MS TAB D

Dispenser for grinding materials in rolls, for NTools organizing boards

NTools MS TAB D is a module designed to expand the possibilities of NTools series organizing boards, granting additional functionalities. The dispenser is intended for mounting sandpaper or grinding fabric in a roll. It features a pin protecting against the grinding material from falling out of the Fastening. Made from 1.0 mm thick steel, fully powder-coated black.

APP NO.	Weight	Dimensions
170707	0,5 kg	120 x 120 x 220 mm



view video



• NTools GH

Glove and fabric hanger

This module is designed to expand the possibilities of NTools series organizing boards, giving them additional functionalities. The hanger is designed as a dispenser for disposable gloves and sheets of abrasive fabrics available in the APP offer. NTools GH can be also mounted to a wall, e.g. in a workshop or garage. The hanger is made entirely from black powder-coated steel. The set additionally features expansion plugs for individual wall mounting.

> ADVANTAGES

- low weight
- simple installation
- easy operation
- universal size
- sturdy construction

APP NO.	Dimensions	Thickness of the wall
170113	260 x 120 x 75 mm	1,5 mm



• NTools SNP

Extraction station for trial sprays

The spray station is supplied with compressed air. While spraying, the air is extracted from the spray chamber. The station is equipped with a replaceable initial filter, a paper sheet fastening Fastening 250615, and a spray-gun Fastening. Dimensions: 590 x 600 x 550 mm. Weight: 16 kg. Powered by: compressed air, 5-6 bar. Paint Stop Green fabric paint filter. Extraction flue with a diameter of 100 mm.

APP NO.	Weight	Dimensions	Power	Diameter of the exhaust chimney
170401	16 kg	590 x 600 x 550 mm	5-6 bar	100 mm



• NTools Paint Mixing Machine

Paint mixer with agitators

The NTools Paint Mixing Machine is a modern, small and maintenance-free mixer that guarantees proper and precise mixing of base coats and paints available in the APP offer packaged in standard, 3,5 and 4,0 liter metal cans. The mixer is compatible with 1,0 L metal cans when using the NTools Modular Mixing Stand (170359) and the NTools Modular Mixing Lid one-liter can mixer (170356). These elements can be purchased separately. The NTools Paint Mixing Machine is equipped with an on/off switch and manual "TIMER" allowing the user to set a mixing time in a range from 1 to 15 minutes. The device features four sockets with "butterfly" type drives, each independently powered by a 15W electric motor.

APP NO.	Dimensions	Power
170350	25 x 30 x 54 cm	220 -240 V, 50 Hz, 10 A



• APP ZG P

Pneumatic can crusher

The device is designed for crushing empty cans with a maximum volume of 5 L. The crusher may be placed anywhere in the workshop. Can crushing is performed after placing it in the crushing chamber, closing the chamber door and securing the door lock. After completing the can crushing process, disengaging the lock and opening the door, the press piston automatically returns to the starting position.

APP NO.	Description
170601	Reduces the can's volume by up to 90%. Powered by compressed air of 5-6 bars.



• APP MR 2

Pneumatic machine for filling
150–400 ml spray cans

The machines are designed for filling (charging) spray type cans with a capacity of 400 ml or 150 ml with lacquer at a volume of 100 ml and 50 ml respectively.

> REPLACEMENT PARTS:

1. Hydraulic and pneumatic machine tip APP No. 210195
2. Hydraulic and pneumatic machine piston APP No. 210196
3. Hydraulic and pneumatic machine cylinder 400 ml APP No. 210198
4. Hydraulic and pneumatic machine cylinder 150 ml APP No. 210199
5. Can charging adapter 150 ml APP 210200

APP NO.	Description
210191	The pneumatic machine is powered by compressed air with pressure from 5 to 8 bars, and spray can charging takes place automatically.



• NTools MR 5

Manual machine for filling spray cans

NTools MR 5 is a machine designed for manually filling (charging) spray type cans (APP Pre Fill Gas Spray) with a capacity of 400 ml with paint or lacquer with a maximum volume of 100 ml. Made entirely from powder-coated steel. Equipped with a head and plunger and a universal tip that enables filling both "male" and "female" type cans.

> ADVANTAGES

- simple construction
- easy operation
- reliability and mobility
- 4 holes (d8 mm) in the base for fixing the machine to a work countertop
- universal can charging tip with both a "male" and "female" type connector

APP NO.	Weight	Dimensions	Handle length
210189	5,6 kg	155 x 270 x 157 mm	490 mm



view video 



• NTools MR 5

Plunger for the manual 400 ml pressurized
container filling machine

APP NO.	Description
210189T	replacement part NTools MR 5



• NTools MR 5.2

Pin and plunger for the manual 400 ml
pressurized container filling machine

APP NO.	Description
210189S	replacement part NTools MR 5.2



• NTools MR 5.3

Head for the manual 400 ml pressurized
container filling machine

APP NO.	Description
210189G	replacement part NTools MR 5.3



• NTools RWDS

Manual putty filler cartridge extruder

NTools RWDS is a manual extruder for simultaneous dispensation of a filler and curing agent in cartridges. The device consists of a main body which features cartridge mounting slots, an extruding mechanism with a lever, and a release button, two extruding elements mounted on a beam that determines their placement, and a closing plate.

➤ ADVANTAGES

- always maintains mixing proportions of the filler and curing agent
- independent of season, user knowledge and attention
- minimizes filler consumption

APP NO.	Dimensions	Installation
110100	800 x 160 x 125 mm	ekspansjon plug + spacer sleeves



zobacz film 



• Product in use



SPRAY-PAINTING



Various spray-painting products

21-232 SPRAY-PAINTING

- 21-28 Putties and fillers
- 29-36 Base and primers
- 37-46 Top coats
- 47-56 Modular color selection system
- 57-62 Thinners, removers and additives
- 63-67 Repair of plastics
- 69-76 Adhesives and sealants
- 77-84 Car body protection and soundproofing
- 85-96 Abrasives
- 97-106 Masking systems
- 107-118 Polishing
- 119-126 OHS
- 127-132 Fabric filters and spray-painting booth accessories
- 133-154 Workshop auxiliary equipment
- 155-170 • Various spray-painting products**
- 171-178 Spray guns and extruders
- 179-186 Pneumatic grinders
- 187-192 Electric grinders, heat guns and lamps
- 193-198 Work disks
- 199-204 Dust extraction
- 205-208 Radiators
- 209-218 Pneumatics
- 219-222 Spray gun regenerators and washers
- 223-232 Technical sprays

• APP 125 – 400 micron paint strainers

Disposable paper strainers with nylon inserts

Disposable paper strainers with nylon inserts with a 125, 190, 280 and 400 micron mesh, used to eliminate mechanical contaminants from paints and lacquers prior to car body spray-painting.

APP NO.	Type	Dimensions	Sales unit	Col. pack.
250195	APP SN 125	125 microns	pack. 250 pcs.	4 pcs.
250175	APP SN 125	125 microns	pack. 1000 pcs.	4 pcs.
250201	APP SN 190	190 microns	pack. 250 pcs.	4 pcs.
250181	APP SN 190	190 microns	pack. 1000 pcs.	4 pcs.
250200	APP SN 280	280 microns	pack. 250 pcs.	4 pcs.
250180	APP SN 280	280 microns	pack. 1000 pcs.	4 pcs.
250203	APP SN 400	400 microns	pack. 250 pcs.	4 pcs.
250183	APP SN 400	400 microns	pack. 1000 pcs.	4 pcs.



125 microns



190 microns



280 microns



400 microns

• APP Mixing Cup Pro

Paint and lacquer mixing cup + lid

The APP Mixing Cup Pro are disposable cups for mixing paints and lacquers. They are made from elastic and durable plastic (PP) resistant to chemical compounds used in refinishing and industrial spray-shops. The precise scales allow to obtain the required amount of primary spray-ready product while maintaining the mixing proportions. The scales are clearly legible from the inner side of the cup. A scaled addition of 10 or 20% of thinner is provided for to adjust the spray viscosity of the mix.

▶ ADVANTAGES

- elastic and durable material (PP)
- tight lids
- overprint on the outside
- scales legible from the inner side of the cup
- mixing proportions: 2:1, 3:1, 4:1, 5:1, 6:1, 7:1
- thinner addition: 10%, 20%
- volume scale with gradation every 50 ml
- "EASY OPEN" system
- reinforced cup edges and bottom increasing its rigidity
- stable base



Mixing Cup Pro

Paint and lacquer mixing cup

APP NO.	Color	Volume	Sales unit	Col. pack.
250711	transparent	385 / 300 ml	pack. 25 pcs.	8 pcs.
250712	transparent	750 / 600 ml	pack. 25 pcs.	8 pcs.
250713	transparent	1400 / 1100 ml	pack. 25 pcs.	8 pcs.
250714	transparent	2300 / 1900 ml	pack. 25 pcs.	4 pcs.

Mixing Cup Pro

Paint and lacquer mixing cup lid

APP NO.	Color	Volume	Sales unit	Col. pack.
250811	transparent	385 / 300 ml	pack. 50 pcs.	4 pcs.
250812	transparent	750 / 600 ml	pack. 50 pcs.	4 pcs.
250813	transparent	1400 / 1100 ml	pack. 50 pcs.	4 pcs.
250814	transparent	2300 / 1900 ml	pack. 50 pcs.	4 pcs.



APP 250714

APP 250713

APP 250712

APP 250711

• APP Cup Eco 500

Paint and lacquer mixing cup with graded scale

A disposable paint and lacquer mixing cup made from transparent PP, with a capacity of 500 ml. It is designed for preparing a spray-ready product while maintaining the proper mixing proportions with a curing agent and thinner.

Featuring clearly legible scales: 2:1, 3:1, 4:1, 5:1 and a volume scale with markers every 10 ml. A scaled addition of 10 or 20% of thinner is provided for to adjust the spray viscosity of the mix.

APP NO.	Color	Volume	Sales unit
250700	transparent	500 ml	pack. 50 pcs.



• APP SP-Lak System SET

Paint and lacquer preparation set

APP SP-LAK System is a set of disposable mixing cups, system lids, and strainers that, when combined with the right type of connector, can be mounted instead of a standard drop container for APP FX2, DeVilbiss, SATA and Iwata spray-guns. The APP paint and lacquer preparation system is an innovative solution for every spray-painting shpack. The system allows to optimize work during the spray-painting process. It is characterized by the ability to obtain better results while simultaneously reducing costs.

➤ ADVANTAGES

- one cup for mixing and for a gravitational spray-gun
- reduction of the amount of solvent used to wash tools
- quick and easy assembly
- system connection compatible with many spray-gun types
- easy finished product storage
- light and easy to use
- integrated air purging system
- no need to use disposable paint strainers
- sturdy attachment to a spray-gun



APP NO.	Description	Sales unit
250745	paint and lacquer preparation set	set



APP Mixing Cup Pro

The APP Mixing Cup Pro is a disposable cup for mixing paints and lacquers. It is made from elastic and durable plastic (PP) resistant to chemical compounds used in refinishing and industrial spray-shops. The precise scales allow to obtain the required amount of spray-ready product while maintaining the proper mixing proportions. The scales are clearly legible from the inner side of the cup. A scaled addition of 10 or 20% of thinner is provided for to adjust the spray viscosity of the mix.

Cup advantages:

1. Elastic and durable material (PP)
2. Tight lid
3. Overprint on the outside
4. Scales legible from the inner side of the cup
5. Mixing proportions: 2:1, 3:1, 4:1, 5:1, 6:1, 7:1
6. Thinner addition: 10%, 20%
7. Total capacity / scale on the cup: 750/600ml
8. "EASY OPEN" system
9. Reinforced cup edges and bottom increasing its rigidity
10. Stable base

APP 250712

----- Paint and lacquer mixing cup 750/600 ml



APP SP LAK System Lid

The system lid for the 750/600ml cup is a component of the APP SP-LAK System set. The lid features an integrated ventilation system that equalizes the pressure inside the cup while spray-painting. The lid also has a space for tightly mounting a paint strainer with a mesh size of 130 or 200 microns.

APP 250815

----- 750/600 ml mixing cup system lid

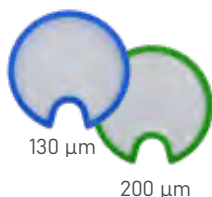

APP SP LAK System Sep

The APP SP LAK System Sep are disposable nylon strainers used to eliminate mechanical contaminants from paints and lacquers before painting. The strainers are available in two variants: 130 and 200 microns. The 130 micron strainer is designed for work with water-dilutable paints, while the 200 micron strainer is intended for conventional spray-painting.

APP 250729

----- System strainer for paints and lacquers 130 µm (blue)

APP 250730

----- System strainer for paints and lacquers 200 µm (green)

APP SP LAK System Red

APP SP LAK Red are four specialized connectors made from stainless steel, designed for correct fastening of a system lid and cup to spray-painting guns.

APP SP LAK System Red 1

APP 250731

1 ----- SATA 100, 1000, 3000, 4000, 5000 system connector

APP SP LAK System Red 2

APP 250732

2 ----- Iwata W400 system connector

APP SP LAK System Red 3

APP 250733

3 ----- Iwata WS400 / AZ3HTE system connector

APP SP LAK System Red 4

APP 250734

4 ----- DeVilbiss / APP FX1 system connector

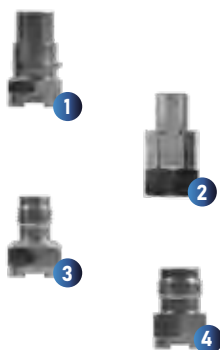

• APP Cup-System

Paint and lacquer mixing cup + insert + lid

The APP paint and lacquer mixing cup system is based on 3 integrated elements: a cup featuring scales of 1:1, 2:1, 3:1, 4:1, 5:1 and 10:1, a replaceable cup insert and a lid.



Cup System Ex

Paint and lacquer mixing cup

APP NO.	Option	Volume	Sales unit	Col. pack.
250701	small	640 ml	pcs.	12 pcs.
250702	medium	1260 ml	pcs.	12 pcs.
250703	large	2520 ml	pcs.	12 pcs.

Cup System In

Paint and lacquer mixing cup insert

APP NO.	Option	Volume	Sales unit	Col. pack.
250901	small	640 ml	pcs.	240 pcs.
250902	medium	1260 ml	pcs.	240 pcs.
250903	large	2520 ml	pcs.	240 pcs.

Cup System Lid

Paint and lacquer mixing cup lid

APP NO.	Option	Volume	Sales unit	Col. pack.
250801	small	640 ml	pcs.	50 pcs.
250802	medium	1260 ml	pcs.	50 pcs.
250803	large	2520 ml	pcs.	50 pcs.



• APP Cup-100

Sealable paint and lacquer mixing cup

A sealable paint and lacquer mixing cup with a capacity of 100 ml and a lid.

APP NO.	Option	Volume	Sales unit
250710	transparent	100 ml	pcs.



• APP P Cup

Container with lid and seal

Elastic and durable containers with lids made from a high quality, thinner-resistant plastic material. They feature a convenient handle for lifting, a seal and a lid securing the container's contents.

APP NO.	Color	Volume	Sales unit	Col. pack.
250215	white	0,55 L	pcs.	2700 pcs.
250216	white	1,0 L	pcs.	2700 pcs.
250217	white	3,0 L	pcs.	600 pcs.
250218	white	5,0 L	pcs.	1000 pcs.
250219	white	10,0 L	pcs.	440 pcs.
250223	white	20,0 L	pcs.	240 pcs.



• APP PP HDPE

Auxiliary container with graded scale, top cap and seal

HDPE auxiliary containers with a graded scale and cap. The APP No. 250209 auxiliary container is equipped with a rubber seal which additionally secures the container. There is a possibility to stack the sealed containers on a pallet.

APP NO.	Color / Option	Volume	Sales unit	Col. pack.
250204	transparent	0,25 L	pcs.	300 pcs.
250205	transparent	0,50 L	pcs.	300 pcs.
250206	transparent	1,0 L	pcs.	180 pcs.
250207	transparent	0,15 L	pcs.	360 pcs.
250208	transparent	5,0 L	pcs.	32 pcs.



• APP CAN

Paint can + lid

Tight, cylindrical paint cans with lids. Made from steel sheet zinc coated on one side.

APP NO.	Volume	Sales unit	Col. pack.
250210	640 ml	pcs.	99 pcs.
250211	1260 ml	pcs.	99 pcs.



• APP Bucket T

Paint bucket + lid

A "Tulip" type conical bucket with a capacity of 2,5 L, 3,0 L, 5,0 L, 10,0 L and 20,0L made from zinc coated sheet metal. The lid features a seal and additional embossing which ensures maximum tightness. The bucket (10 L, 20 L) features additional protection against lid opening in the form of a ring with a lever clamp and seal. The bucket is equipped with bow for easier transport.

The packaging is primarily used for storing paint and lacquer industry products, and by paint manufacturers.

APP NO.	Volume	Sales unit	Col. pack.
250212	2,5 L	pcs.	100 pcs.
250213	3,0 L	pcs.	100 pcs.
250214	5,0 L	pcs.	100 pcs.
250221	10,0 L	pcs.	242 pcs.
250222	20,0 L	pcs.	120 pcs.



• APP KF 1

Ford Cup

A Ford cup (viscosity meter) with a diameter of 4 mm used to measure the viscosity of paints and lacquers. The viscosity measurement is carried out by filling the cup with a liquid and allowing the liquid to freely flow out through the opening in the cup's bottom. The time to full drainage of the liquid is given in seconds and is directly proportional to the liquid's viscosity.

APP NO.	Description
250100	The Ford cup is most often used during paint and lacquer preparation for spray-on application using a spray-gun, where it is important to prepare a lacquer of appropriate viscosity.



• APP Paint Mixing Sticks

A set of disposable paint and lacquer mixing instruments

APP Paint Mixing Sticks is a set of mixing sticks made from polypropylene (PP) in a shape resembling the letter "S". Thanks to its structure and additional openings, they allow to thoroughly mix paints and lacquers. The APP Paint Mixing Sticks are widely used in spray-painting and carpentry workshops. They are resistant to cleaners and solvents.

➤ ADVANTAGES

- ensure quick mixing
- feature additional openings on the body
- resistant to cleaners and solvents
- the cardboard package also serves as a dispenser

APP NO.	Color	Sales unit
250020	blue	pack. 500 pcs.
250021	blue	pack. 25 pcs.



• **APP MTurbo 10**
Paint mixer – plastic (30/275 mm)

The plastic mixer can also be used as a practical can opener.

APP NO.	Dimensions	Sales unit
250012	30 x 275 mm	pack. 10 pcs.



• **APP M OTW**
Mixer with a can opener

APP M OTW is a metal mixer for manually mixing top coat lacquers, base paints, primers, spray-on fillers, and other liquid chemical products.

➤ **ADVANTAGES**

- the end of the grip is also an opener for cans sealed using push-in lids
- the plastic grip is resistant to chemicals, including acetone

APP NO.	Description
259010	is made from electrogalvanized steel and features high mechanical strength



• **APP M Skal**
Aluminum graded strip for mixing chemically hardened products

A lacquer mixing strip that allows convenient and efficient mixing of paint up to a volume of 1l. It features the following mixing scale grades: 2:1, 3:1, 4:1, 5:1.

APP NO.	Weight / Dimensions	Sales unit	Col. pack.
259001	2:1, 4:1	pcs.	50 pcs.
259002	2:1, 5:1	pcs.	50 pcs.
259003	2:1, 3:1	pcs.	50 pcs.



• **APP MD 10 i Mmini 1000**
Wooden paint and lacquer mixers

Universal mixers for primers, base coats and lacquers made from beech wood. Very durable, resilient, and resistant to breaking. The mixers are multiple use, easy to clean, resistant to solvents. The mixers are available in dimensions: 2,2 x 35 cm and 3,5 x 40 cm and 6 x 140 mm.

APP NO.	Dimensions	Sales unit
250013	22 x 350 mm	pack. 10 pcs.
250014	35 x 400 mm	pack. 10 pcs.



• **APP SAS**
Anti-static cloth

The APP SAS dust cloth is intended for cleaning dust contamination and base lacquer dry spray off surfaces during refinishing spray-painting and in many industrial application prior to spray-on painting. Dimensions 45 x 90 cm.

APP NO.	Dimensions	Sales unit
250501	900 x 450 mm	pack. (50 pcs.)
250502	900 x 450 mm	pack. (10 pcs.)



• APP SAS AQUA

Anti-static cloth

The APP SAS AQUA dust cloth is intended for cleaning dust and the finest contaminants from surfaces intended for painting with water-dilutable bases.

Dimensions 195 x 460 mm.

APP NO.	Dimensions	Sales unit
250503	460 x 195 mm	pack. 10 pcs.



• APP Dry Coat

Testing powder

APP Dry Coat Set is a testing powder for checking the quality of a sanded surface. After application during sanding, it shows scratches, pores, cavities and surface defects, enabling its thorough preparation for painting.

➤ ADVANTAGES

- for dry and wet grinding
- does not contain solvents
- does not require drying time
- does not require masking
- does not clog the sandpaper

APP NO.	Description	Color	Weight / Dimensions	Col. pack.
250050	set	black	100 g	12 pcs.
250051	refill	black	100 g	18 pcs.



• APP Kontroll Spray

Compound for checking the quality of sanded surfaces

APP Kontroll Spray is a compound facilitating perfect surface preparation.

➤ ADVANTAGES

- convenient use
- quick drying
- does not clog the sandpaper

APP NO.	Description	Volume	Col. pack.
210915	During sanding, it exposes areas of scratches, pores, cavities and surface defects, enabling its thorough preparation for painting.	400 ml	6 pcs.



• APP TSK 100

Paper test card

A card that enables performance of a test spray, facilitates choosing the appropriate color and control of the coverage of applied paint.

APP NO.	Description
250601	The APP TSK 100 paper test card features a spectral grey area which makes it easier to identify the base color that needs to be used under the colors with less hiding power.



• APP TKM

Metal test card

Metal test spray panels enabling performance of test sprays in conventional and water-dilutable systems. The black strip on a bright background facilitates assessment of the applied color's hiding power,

APP NO.	Description
250610	The panels allow performance of adhesion and elasticity tests of the applied coats.



• NTools SMN Set i SMS Set

Stainless metal and regular steel spatulas

The spatulas allow application of filler on the processed surfaces and mixing the filler putty with the curing agent. The metal spatula set consists of 4 pieces with widths of 5, 8, 10 and 12 cm.

➤ APPLICATION

- application of filler on various types of surfaces
- mixing filler putty with a curing agent
- in construction works: plastering, filling only for SMN SET spatulas
- the SMN SET spatulas are also intended for applying water-dilutable products

APP NO.	Option	Dimensions	Sales unit
250311	NTools SMN Set / metal stainless	5,8,10,12 cm	pack. (4 pcs.)
250312	NTools SMS Set / metal steel	5,8,10,12 cm	pack. (4 pcs.)



• APP STS

Copolymer spatulas

Spatulas designed for applying any chosen kind of filler. Durable and elastic, for work on flat and curved surfaces. They are made from a PP/PE copolymer characterized by very high mechanical strength and elasticity. They do not scratch the processed surface. The spatulas feature a flat upper edge with a riser that enable a sure grip, and a lower, very elastic side, tapered to a shape of a blade, allowing to very precisely and smoothly apply filler on elements of varying shapes.

➤ ADVANTAGES

- very high elasticity
- does not scratch the filled surface
- flat upper edge with rigid riser facilitating a secure grip
- repeatability of production – guarantee of identical properties of every unit

APP NO.	Color	Dimensions	Sales unit
250305	red	5 x 6 x 9 cm 7 x 8 x 9 cm 12 x 11 x 9 cm	pack. 3 pcs.
250304	red	12 x 11 x 9 cm	pack. 2 pcs.



• APP S Gum

Rubber spatula

Very elastic and mechanically resilient rubber spatulas. Designed for work on arches with a very small curvature radius.

APP NO.	Dimensions
250330	6 x 10 cm



• APP PDS 30

Filler putty mixing pad – horizontal (30 sheets)

A filler mixing pad is an indispensable product when working at a spray-painting shop. 30 disposable cardboard sheets allow thorough mixing of the curing agent with a polyester filler. The sheets' work surface is coated with a film protecting against moisture and absorption of the product. The cardboard block is glued on two sides, which facilitates tearing off sheets. A stable base and a large, film coated sheet surface are arguments in favor of this simple and reliable solution.

➤ ADVANTAGES

- stable base
- large working surface
- non-absorbent, film coated sheets

APP NO.	Description	Dimensions	Sales unit
250011	30 sheets	250 x 175 mm	pcs.



• APP PDS 100

Filler putty mixing pad – vertical (100 sheets)

APP PDS100 is a filler mixing pad containing 100 sheets with dimensions of 245 x 215 mm and a surface density of 90g/m², enabling thorough mixing of a curing agent with the polyester filler putty. Chalky paper protects the sheet surface against moisture and absorption. The block is glued at three edges, ensuring sturdy fastening of the sheets on a stiff base. The filler mixing pad is an essential product in any spray-painting shop

➤ ADVANTAGES

- stable base
- large working surface 245 x 215 mm
- large number of sheets
- non-absorbent chalk paper sheets
- sheet block glued on three sides

APP NO.	Description
250009	A stable base and 100 sheets of non-absorbing chalk paper are arguments in favor of this simple and reliable solution.



• APP KSP

Foam grinding block

A foam grinding block intended for dry and wet grinding using sand paper. The foamed plastic base ensures low weight and floatability. The stiffening inserts in the flat blocks prevent deformation of the working surfaces and increase their rigidity.

APP NO.	Description	Option	Dimensions	Col. pack.
150203	A	-	210 x 75 x 27 mm	100 pcs.
150204	B	-	140 x 75 x 27 mm	100 pcs.
150205	C	rounded	140 x 45 x R20	100 pcs.
150206	D	-	290 x 75 x 27 mm	100 pcs.
150207	E	-	135 x 75 x R20	100 pcs.



• APP KSK

Cork grinding block

Made from cork, which guarantees the block's low weight and allows both wet and dry work. It is compatible with 230 x 280 waterproof sandpapers.

APP NO.	Material	Dimensions
150102	cork	115 x 60 x 25 mm



• APP KSG

Rubber grinding block

An elastic grinding block for attaching sandpaper using special fasteners. It is intended for both wet and dry grinding. It is compatible with 230 x 280 waterproof sandpapers.

APP NO.	Material	Dimensions	Fastening
150101	gumowy	130 x 70 mm	zaczep



• APP KSZ

Grinding block with latches

Made from plastic, it features two latches for fastening the sandpaper. The work plate is coated with an additional layer of rubber, which, together with the latches, prevents shifting of the sandpaper in relation to the work plate. The block is intended for both wet and dry work.

APP NO.	Option	Dimensions	Fastening	Col. pack.
150201	small	165 x 87 mm	zatrask	60 pcs.
150202	large	212 x 105 mm	zatrask	60 pcs.



• APP KS BLOCK

Grinding C block, Velcro

A grinding C block made from a very light plastic material. Intended for work with all abrasive disks with a 150 mm diameter.

APP NO.	Dimensions	Fastening
150251	d150	rzep



• APP SP

Straight hand grinder

The straight grinder are designed for sanding large and flat surfaces.

The A, B, C and D grinders feature a wooden grip and work plate made from aluminum, which guarantees maintaining flatness and low weight of the tool. The H grinder is made from plastic, with an elastic work plate, which facilitates adaptation to the surface shape.

The hand grinders feature clamps what ensure good adhesion of the abrasive material to the work plate.

APP NO.	Description	Material	Dimensions	Fastening
150301	A	wood	70 x 400 mm	clamp
150310	H1	made of plastic	70 x 400 mm	clamp
150302	B	wood	70 x 240 mm	clamp
150303	C	wood	70 x 170 mm	clamp
150304	D	wood	70 x 200 mm	clamp

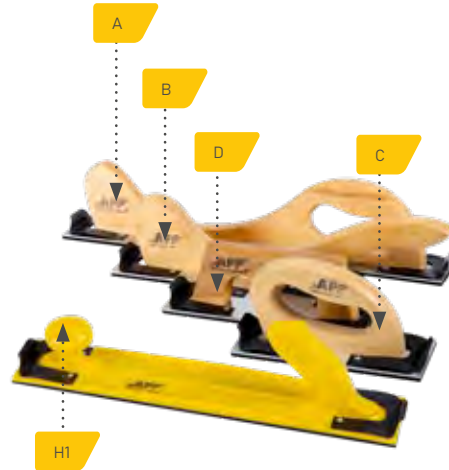

• APP P100

100 ml HDPE auxiliary container with applicator

The APP P100 auxiliary container with applicator with a capacity of 100 ml is made from HDPE plastic resistant to most liquids. The container is equipped with an innovative drop applicator enabling precise measurement of its content. IT is characterized by high elasticity and resistance to compression. The screw cap allows to tightly secure the liquid against leaking, and the knob allows precise dosage. The product is intended for storing most chemical liquids used in the cosmetic varnishing industry.

APP NO.	Color	Volume
250224	transparent	100 ml



• APP TPP20

Touch-up paint container

The APP TPP20 2in1 touch-up paint container is a product intended for storing paint or lacquer featuring a small brush for performing touch-ups, and a rapidograph. The 2in1 bottle, thanks to a special needle, allows application of a consistently thick line on any location on the car's body.

➤ ADVANTAGES

- small volume - 20 ml
- 2w1 packaging
- glass ball to facilitate mixing
- brush for precise application
- rapidograph for filling scratches
- ergonomic shape (imitating a marker)
- can be hung
- cap with needle protection

APP NO.	Description	Volume	Sales unit
250226	2 w 1	20 ml	pack. 10 pcs.



• APP TPB20

Touch-up paint container with brush and mixing ball

The APP TPB20 touch-up paint container is a product intended for storing paint or lacquer, featuring a brush for performing touch-ups and a metal ball for thoroughly mixing the container's contents. The brush is made from synthetic bristle, is very delicate and is designed for precise application.



➤ ADVANTAGES

- small volume – 20 ml
- screw cap providing additional sealing
- metal ball to facilitate mixing
- brush for precise application



APP NO.	Volume	Sales unit
250227	20 ml	pack.100 pcs.
250237	20 ml	pack.10 pcs.

• APP Micro Brush

Touch-up brush sticks with applicator

The APP Micro Brush are disposable, non-dusting sticks for performing paint touch-ups. The sticks are made from plastic and the paint applicator is made from a nonwoven fabric. The APP Micro Brush sticks are designed for applying any type of paint or lacquer while performing repairs of small chips in the paint coating.



➤ ADVANTAGES

- non-dusting applicator material
- three different applicator sizes: 1,0 mm – white, 1,5 mm – yellow, 2,0 mm – blue
- precise paint and lacquer application
- ergonomic shape and small weight
- tightly sealed packaging



APP NO.	Color	Dimensions	Sales unit
250228	white	1,0 mm	pack. 100 pcs.
250229	yellow	1,5 mm	pack. 100 pcs.
250230	blue	2,0 mm	pack. 100 pcs.

• APP ZPW

Touch-up brush set

Brushes from natural bristle.



APP NO.	Description	Sales unit
250008	for very small and precise repairs of paint defects	set. 3 pcs.



• APP PPL

Flat PCV brush

Brushes made from thinner-resistant plastic for applying sealing masses.



APP NO.	Description	Weight / Dimensions
250005	flat	25 mm
250006	flat	36 mm
250007	flat	50 mm



- **APP SZP 1L**

Remover compound sprayer with pump

The sprayer allows for significant remover savings and its even distribution on the cleaned surface of the car bodywork.

APP NO.	Description
251100	The pump sprayer is chemically resistant to the effects of solvent-based removers.



- **APP ZU Set**

Set of seals for the SZP 1L sprayer

The set is intended for periodic replacement of the factory seals worn through natural exploitation and damage caused by using unsuitable, aggressive solvents (e.g. NITRO) in the sprayer.

APP NO.	Color	Set
251101	green	o-ring 36,0 x 4,0 - 1 pcs. o-ring 14,0 x 3,5 - 1 pcs. o-ring 3,0 x 2,7 - 1 pcs. o-ring 5,0 x 1,5 - 3 pcs. seal - 1 pcs.



- **APP SDD**

Sprayer for detergents and water

The advantage of using the sprayer is the ability to quickly apply mixtures of detergents and water onto large surfaces.

APP NO.	Material	Volume	Sales unit
251106	PE	1,0 L	pcs.



- **APP B-Neck**

Long-necked bottle + cap

APP B-Neck is an ergonomic, long-neck bottle with an included cap, made from polyethylene PE, with a capacity of 1,0 L. The bottle is designed for storing all kinds of detergents and water. The APP B-Neck is compatible with triggers available in the AP offer (APP No. 251102 and 251103)

APP NO.	Material	Volume	Sales unit
251112	PE	1,0 L	pcs.



- **APP Trigger 1**

Sprayer pump

A manual sprayer with single-action operation, intended for detergents, water, and non-aggressive chemicals. It is characterized by very high manufacturing quality and efficiency. The pump's output is approx. 1,20 ml of liquid.

APP NO.	Description
251102	The sprayer features a nozzle with an adjustable spray angle. It is perfect for detailing works with diluted solutions. The suction tube is fitted with a liquid filter



• APP Trigger 2 Sprayer pump

A modern, manual sprayer designed for applying and dispersing liquids, including solutions of cleaning compounds, and for applying car care products.

ADVANTAGES

- viton seal with heightened resistance to the effects of aggressive chemicals
- double-action pump construction – pumps during lever motion in both directions (push and release)
- adjustable nozzle allowing to change the stream from focused to highly dispersed
- installed filter for the pumped liquid
- durability approx. 40000 work cycles (parameter determined during work with demineralized water)



APP NO.	Description
251103	pump output in two motions – approx. 3 ml of liquid

• APP AD 3000 Pressure sprayer with lance

The AD 3000 3L pressure sprayer with a lance is a professional device for washing, cleaning, decontamination, neutralization, and application of impregnating compounds and other chemical compounds containing acids and corrosive substances. The incorporated viton seal is non-reactive to chemically aggressive and non-neutral agents.



APP NO.	Description
251109	It is intended for applying detergents onto large surfaces, e.g. car bodyworks, workshop floors. It is not compatible with paint cleaners, e.g. W900.

• NTools CS 12 12 part spray-gun cleaning kit

A spray-gun cleaning kit including brushes, tufts and cleaning rods.



APP NO.	Amount of elements	Sales unit	Col. pack.
250103	12 pcs.	pcs.	pcs.

• NTools CS 22 22 part spray-gun cleaning kit

A spray-gun cleaning kit including brushes, tufts and cleaning rods.



APP NO.	Amount of elements	Sales unit	Col. pack.
250105	22 pcs.	pcs.	pcs.

- **APP Screw Cup DIN 45**

Dosing cap with a tap

The APP Screw Cup DIN 45 (inner inlet diameter 34,5 mm) is a dosing cap with a tap for use with 5 L and 10 L capacity canisters in order to dispense concentrates, which facilitates pouring liquids from large containers.

APP NO.	Description
220198	The cap features an inner seal which additionally secures the canister.



- **APP Screw Cup DIN 51**

Dosing cap with a tap

The APP Screw Cup DIN 51 (inner inlet diameter 43,6 mm) is a dosing cap with a tap for use with 5 L and 10 L canisters in order to dispense concentrates, which facilitates pouring liquids from large containers.

APP NO.	Description
220196	The cap features an inner seal which additionally secures the canister.



- **APP Screw Cup DIN 61**

Dosing cap with a tap

The APP Screw Cup DIN 61 (inner inlet diameter 48,5 mm) is a dosing cap with a tap for use with 25 L and 30 L canisters in order to dispense concentrates, which facilitates pouring liquids from large containers.

APP NO.	Color / Option
220199	The cap features an inner seal which additionally secures the canister.



- **Product in use**



• APP SK Set

Car windshield cleaning scraper
+ blade set (100 pcs.)

The scraper is made from stainless steel and comes with a set of 100 easily replaceable blades. It features a special lock protecting the blade against moving during work. The tool is intended for removing very dried and clingy contaminants, such as paint, filler, glue, etc. from glass or other smooth surfaces.

APP NO.	Description	Sales unit
250110	scraper	-
250111	replacement blades 39 x 19 mm	pack. 100 pcs.



APP 250111



APP 250110

• NTools CUT X

Professional cutting blade

The NTools CUT-X knife is a tool recommended for all kinds of production, warehouse, workshop or assembly works. The blade allows cutting of materials of varying thickness and resilience, including soundproofing mats, leather, rubber, paper or thin plastic. The blades are made from metal and aluminum, and the casings are additionally coated with rubber ensuring a secure grip and protecting them against accidental damage. The NTools Cut-X features a built-in magazine for 5 pieces of replaceable blades and a blade lock protecting against accidental deployment.

APP NO.	Weight	Dimensions	Sales unit
250120	230g	170 x 50 x 27 mm	pcs.



• NTools C 18

Replacement knife blades

C-18 are high quality, replacement break-off blades for the NTools knives. They are made from tool steel and are characterized by long service life and increased hardness. They owe their amazing sharpness to a cutting edge that has been laser-sharpened in three planes, which guarantees cutting precision and ease. The blades are intended for cutting materials of varying thickness and resilience, including soundproofing mats, leather, rubber, paper, foil and cardboard or thin plastic.

APP NO.	Weight	Dimensions	Sales unit
250125	230g	170 x 50 x 27 mm	pcs.



- **APP GCX**

Pressed cellulose sponge

A highly absorbent sponge intended for work with detergent cleaning compounds and matting pastes.

APP NO.	Color	Dimensions	Sales unit
220201	yellow	110 x 35 x 5 mm	pcs.



- **APP G1**

Car bodywork washing sponge

A strong, CFC-free sponge with large dimensions and high absorption for general purpose use.

APP NO.	Color	Dimensions	Sales unit
220205	yellow	180 x 120 x 60 mm	pcs.



Karoseria



- **APP S2**

Soft sponge for insect removal

A soft, synthetic, low-foaming sponge with open pores. Thanks to its structure, it is aggressive to staining and dirt, while also gentle to delicate surfaces. It can be safely used on lacquered surfaces.

APP NO.	Color	Dimensions	Sales unit
220211	yellow	165 x 110 x 55 mm	pcs.



Szyby



Karoseria



- **APP G3**

Hard sponge for cleaning coverings and upholstery

A sponge for removing persistent stains from coverings and upholstery of motor vehicles.

APP NO.	Color	Dimensions	Sales unit
220215	yellow	110 x 80 x 50 mm	pcs.



SPRAY-PAINTING



Spray guns and extruders

21-232 SPRAY-PAINTING

- 21-28 Putties and fillers
- 29-36 Base and primers
- 37-46 Top coats
- 47-56 Modular color selection system
- 57-62 Thinners, removers and additives
- 63-67 Repair of plastics
- 69-76 Adhesives and sealants
- 77-84 Car body protection and soundproofing
- 85-96 Abrasives
- 97-106 Masking systems
- 107-118 Polishing
- 119-126 OHS
- 127-132 Fabric filters and spray-painting booth accessories
- 133-154 Workshop auxiliary equipment
- 155-170 Various spray-painting products
- 171-178 • Spray guns and extruders**
- 179-186 Pneumatic grinders
- 187-192 Electric grinders, heat guns and lamps
- 193-198 Work disks
- 199-204 Dust extraction
- 205-208 Radiators
- 209-218 Pneumatics
- 219-222 Spray gun regenerators and washers
- 223-232 Technical sprays

• NTools FX2 PLUS

HPS spray-painting gun

The NTools FX2 PLUS HPS spray-painting gun is a development version of the popular FX1 Plus model. It operates in the patented HPS technology ensuring excellent atomization and high transfer. The new, light and ergonomic, pressure-cast aluminum body is covered with an anti-adhesion coating. The nozzle and pin are made from AISI303 stainless steel, the new head types from nickel-plated brass. It features sealing elements from PTFE and a new 600 ml gravity tank. The spray-gun is available with 1,2; 1,3; 1,7; 1,9 nozzles and is intended for paint refinishing works, as well as priming and base application. The spray-gun ensures an excellently balanced ratio of durability, quality, and price.

APP NO.	Description	Nozzle
160602	upper tank	d1,2
160603	upper tank	d1,3
160607	upper tank	d1,7
160609	upper tank	d1,9
639881	NTools ZOP 6 gravity tank	-
639101	Paint filter (strainer) APP FF 10	-
639945	NTools UK 1 nozzle key	-



• NTools FX1 mini

Spray-painting gun for Smart repairs

The NTools FX1 mini is a small, light and ergonomic spray-gun designed for SMART type paint repairs.

The pressure-cast aluminum body is covered with an anti-adhesion coating. The nozzle and pin are made from stainless steel and allow use of thinner-based and water-dilutable paints. Heads are made from nickel-plated brass and sealing elements from PTFE. The nylon tank has a capacity of 250 ml.

The spray-gun operates in the patented HPS technology ensuring excellent atomization and high transfer. It is intended for paint refinishing works, as well as priming and base application. The spray-gun's small weight and ergonomic body guarantee easy operation.

APP NO.	Description	Option	Nozzle
160508	upper tank	HPS	d0,8
639971	NTools ZOP 10 gravity tank	-	-
639945	nozzle key NTools UK 1	-	-



• NTools SG 1002

Spray-painting gun

The NTools SG 1002 spray gun, due to its head's operating parameters and moderate compressed air requirement, is intended for many areas of work in production and servicing applications.

➤ Intended for spray-on application of:

- primers and bases
- filling bases
- acrylic and polyurethane paints
- colorless lacquers
- water-dilutable lacquers

APP NO.	Description	Option	Nozzle
161914	upper tank	HVLP	d1,4
161917	upper tank	HVLP	d1,7
639881	gravity tank NTools ZOP 6	-	-
639101	APP FF 10 Paint filter (strainer)	-	-
639945	NTools UK 1 nozzle key	-	-



• NTools SG 828

Spray-gun

The NTools SG 828 spray gun, due to its head's operating parameters and moderate compressed air requirement, is intended for many areas of work in production and servicing applications.



► Intended for spray-on application of:

- primers and bases
- filling bases
- acrylic and polyurethane paints
- colorless lacquers
- water-dilutable lacquers



APP NO.	Description	Option	Nozzle
161933	upper tank	HVLP	d1,3
161934	upper tank	HVLP	d1,4
161935	upper tank	HVLP	d2,0
161936	upper tank	HVLP	d,2,5
639881	gravity tank NTools ZOP 6	-	-
639101	APP FF 10 Paint filter (strainer)	-	-
639945	NTools UK 1 nozzle key	-	-

• NTools PM

Spray-gun for sealing mass

NTools PM spray gun for applying one-component, polymer, spray-on sealing masses (MS – Polymer) in cartridge type packages of a maximum volume of 310 ml. It enables recreation of the factory "scale / braid" type textures, spray-on sealing of welding seams or welded connections. The spray-gun may be used to obtain a dashed type texture and additionally extrude polymer mass rolls.



► ADVANTAGES

- construction based on a classic spray-gun with a pressured container
- very broad adjustment range
- does not require washing after proper preparation for putting away
- the set contains an extrusion head with a thread for mounting nozzles provided separately



APP NO.	Description
110501	cartridge type packages of a maximum volume of 310 ml

• NTools BS 2

Maintenance pressure gun

The NTools BS2 spray-gun with a 1,7 mm nozzle and a bottom pressure container is designed for quick, spray-on application of bodywork corrosion and stone impact protection preparations, such as pebbledash, bituminous masses and waxes. The spray-gun features adjustment of the sprayed material using a pin and through adjusting the working pressure in the tank. The pressure tanks is compatible with typical, disposable 1,0 L packages with a 42 x 3 mm thread, or can be used individually.



► ADVANTAGES

- enables work with very dense products
- maximum range of spray parameter adjustment
- allows to obtain a precise mix of wax and air before injection into closed profiles
- the set contains one probe **D** with a diameter of 6 mm and length of 1,5 m and three cooperating, replaceable nozzles for work with wax inside the closed profiles: straight nozzle with a circular stream **E**, a straight nozzle with a conical stream **F** and an angular nozzle with a flat stream **G**



APP 110105N



APP 110107

APP NO.	Description
110105N	spray-gun / Nozzle 1,7 mm
110107	flexible probe for anticorrosion protection of closed profiles

• NTools RA/1

Spray-gun for preserving agent application

The NTools RA/1 spray and suction gun is designed for spray-on application of preparations for protecting the car's bodywork against stone impacts, bituminous masses and waxes. The gun is equipped with an adjustable nozzle that enables adjustment of the amount of sprayed mass from zero to the maximum amount corresponding to the given working pressure. This mechanism allows to obtain various textures for securing side sills and sealing welded connections.

➤ ADVANTAGES

- adjustable nozzle
- for wax injection, features a probe with a length of 0,5 m with a circular stream nozzle
- durability and low weight
- adapted for typical, 1-liter (1-2 kg) disposable packages with a 42 x 3 mm thread

APP NO.	Description
110101	flexible probe 0,5 m / the spray-gun is suitable for 1 liter packages



• NTools PS6

Preserving agent spray-gun with probe

NTools PS6 spray and suction gun intended for spray-on application of preparations protecting the bodywork against stone impact, bituminous masses and waxes.

➤ ADVANTAGES

- features a probe for wax injection
- low weight
- adapted for typical, 1-liter disposable packages with a thread

APP NO.	Description
110104	the spray-gun is suitable for 1 liter packages



• NTools PWW 400

Pneumatic multipurpose extruder for 310 ml cartridges and 400 ml pouches with a telescopic plunger

NTools PWW 400 is a plunger-based extruder and spray-gun for sealing masses all in one tool. It is intended for applying spray-on sealing masses in cartridge type packaging with a maximum capacity of 310 ml. It enables recreation of factory "scale / braid" type textures of spray-on seals on welding seams or hot-welded connections. The gun can be used to obtain a dashed texture and very precisely extrude sealant rolls from any type of mass packaged in a cartridge or a pouch with a capacity of up to 400 ml.

➤ ADVANTAGES

- telescopic plunger enabling very precise extrusion
- a set of replaceable nozzles and adjusters allowing to obtain many pneumatic spray textures
- short and compact construction
- easy to maintain and keep clean

➤ TECHNICAL DATA

APP NO.	110505N
Description	NTOOLS PWW 400 max cartridge / poche 400 ml
Working pressure	6-8 bar
Max. pressure	10 bar
Air consumption	220 l / min
Compressed air quick-coupling	1/4" (outer thread)
Noise level	70 dB(A)
Length	395 x 220 mm
Diameter	64 mm
Masas	1,24 kg





• NTools D

Working nozzle for NTools PWW 400

Working nozzles are an essential element of NTools PWW 400 guns for executing spray-on "scale / braid" type seals and "dashed" coating protecting against stone impacts.. They can be washed in tool cleaning solvents.

➤ NTools DW - APP Nr 110505WK

NTools DW is an internal, multiple-use nozzle for sealing mass extrusion. It features a thread for connecting with a cartridge type sealant package made from plastic or aluminum.

Nozzle color - transparent white.



APP 110505WK

➤ NTools DR - APP Nr 110505ZR

NTools DR (Renault) is an external, multiple-use, long air nozzle for the NTools PWW 400 gun, attached to the NTools DW mass nozzle and mounted to the gun body. It allows to obtain a clean sealant track without side fraying, using a small and medium amount of mass. Through forming its tip and shortening the length, the nozzle allows to create many different textures.

Nozzle color - black.



APP 110505ZR

➤ NTools DVW - APP Nr 110505ZV

NTools DVW (VW) is an external, multiple-use, short air nozzle for the NTools PWW 400 gun, attached to the NTools DW mass nozzle and mounted to the gun body. It allows to obtain only a coarse, frayed track of sealant using a large and very large amount of mass. In emergency situations, it allows to extrude masses from pouches.

Nozzle color - black.



APP 110505ZV

APP NO.	Description	Option	Type of nozzle
110505WK	cartridge	internal	white
110505ZR	long	external	Renault
110505ZV	short	external	VW

• NTools CSG II 245 RP

Pneumatic extruder for 310 ml cartridges and 300-400 ml pouches

The NTools CSG II 245 RP pneumatic extruder is designed for extruding adhesive and sealing masses in cartridge type packages with a maximum capacity of 310 ml made from plastic or aluminum, and 400 ml pouches. Extrusion of the mass takes place via compressed air acting directly on the cartridge plunger. The gun features a differential valve increasing work comfort.

➤ ADVANTAGES

- very good ergonomics
- high extrusion precision
- release of the trigger causes immediate flow stop
- short frame

APP NO.	Description
110402	maximum volume cartridge / poche 300 - 400 ml



• NTools CSG II 400 RP

Pneumatic extruder for 300 - 600 ml pouches

The NTools CSG II 400 RP pneumatic extruder is designed for extruding adhesive and sealing masses in pouches with a maximum capacity of 600 ml. Extrusion of the mass takes place via compressed air acting directly on the cartridge plunger. The gun features a differential valve increasing work comfort.

➤ ADVANTAGES

- very good ergonomics
- high extrusion precision
- release of the trigger causes immediate flow stop
- very large extrusion chamber

APP NO.	Description
110413	maximum volume cartridge / poche 300 - 600 ml



• NTools RC/N

Pneumatic extruder for 310 ml cartridges

The NTools RC/N pneumatic extruder is intended for extruding one-component adhesive and sealing masses from cartridge type plastic or aluminum packages with a maximum capacity of 310 ml. Extrusion of the mass takes place via compressed air acting directly on the cartridge plunger.

> ADVANTAGES

- durable and easy to use
- release of the trigger causes immediate mass flow stop
- light and compact construction
- low compressed air requirement

APP NO.	Description
110401	maximum volume cartridge 310 ml



• APP MTL 1

Nozzle with guide for 310 ml cartridges

APP MTL 1 is a nozzle intended for use with aluminum and plastic cartridges. It allows application of sealing mass in the shape of half a roll with a width from 6 to 13 mm. It features two guides allowing for selection of the desired distance of the applied sealant from the element's edge. The nozzle ensures stable guidance of the extruder and mass application as close as possible to the factory application.

> ADVANTAGES

- single-use product
- compatibility with various mounting threads
- stabilizes extrusion for pneumatic and electric tools

APP NO.	Description	Color
110601	to a closed cartridge	grey
110603	into an open cartridge	white



• APP DK 40

Nozzle with guide for 310 ml cartridges

APP DK 40 is a nozzle designed for use with aluminum and plastic cartridges. It allows application of sealing mass up to a width of 40 mm. The nozzle can be narrowed to 20 mm. The embossed scale makes it easier to obtain the desired width.

> APPLICATION

- replication of mass patterns featured on the car body
- joining of bodywork panels
- preservation of, e.g. wheel arches, vehicle floors

APP NO.	Description	Color	Sales unit
110606	hard	black	pack. 5 pcs.
110607	soft	black	pack. 5 pcs.



APP 110606



APP 110607

• NTools HKS

Hand extruder for 310 ml cartridges

NTools HKS hand extruder for extruding adhesive and sealing masses in plastic and aluminum cartridge type packaging with a maximum capacity of 310 ml. It features a 7:1 transfer facilitating smooth extrusion of highly viscous masses.

> ADVANTAGES

- light, frame construction made entirely of metal
- intended for extruding dense products
- 7:1 transfer

APP NO.	Description
110001	transfer 7:1 / maximum volume cartridge 310 ml



• NTools HKS Deluxe

Hand extruder for 310 ml cartridges

NTools HKS hand extruder for extruding adhesive and sealing masses in plastic and aluminum cartridge type packaging with a maximum capacity of 310 ml. It features a 12:1 transfer facilitating smooth extrusion of highly viscous masses.

➤ ADVANTAGES

- rotating tube frame
- reinforced ratchet mechanism
- fully metal structure
- intended for very dense products
- 12:1 transfer

APP NO.	Description
110002	transfer 12:1 / maximum volume cartridge 310 ml



• NTools APL

Hand extruder for 2 x 25 ml cartridges

NTools APL is a manual applicator for simultaneous and precise extrusion (1:1) of cartridges with a capacity of 2 x 25 ml. There are dedicated mixing tips for the extruder available in the APP offer (No. 220622).

APP NO.	Description
220623	for cartridges 2 x 25 ml



• APP NTW 32

Small mixing tips

Mixing tips for chemically hardened products.

APP NO.	Sales unit
220622	pack. (12 pcs.)



• APP MANO 3

Air regulator with manometer

A coaxial glandular compressed air regulator with a mechanical needle manometer for determining the value of working pressure supplied to a spray-gun. The transparent working dial plate cover is made of glass.

➤ TECHNICAL DATA

APP NO.	389296
Description	APP MANO 3 air regulator with manometer
Nominal manometer size	40 mm
Manometer measuring range	10 bar
Max. constant working pressure	7,5 bar
Accuracy class	1,6
Smooth pressure adjustment depending on flow	YES
Manometer body	stal
Regulator body	aluminium
Seals	PTFE
The spray-gun connector features an internal cylindrical thread	1/4" F-BSP
The quick coupler connection features an external cylindrical thread	P 1/4" M-BSP
Weight	135 g



- ! Do not submerge in solvents!
- ! Do not insert into automated spray-gun washers!

• NTools ZL 1

EURO DN 7,2 Quick coupler connector with internal thread G 1/4", brass

A quick coupler connector with a standard EURO DN 7,2 profile with an internal cylindrical thread G 1/4". Made from brass. Intended for spray-guns.

> COMPATIBILITY

- RECTUS 26, RECTUS 25, RECTUS 1600/1625
TEMA 1600, CEJN 320, JWL 520 + JWL 530
and other German products

APP NO.	Description	Dimensions
389257	Internal thread / brass	1/4"



• Iwata ZPG

Articulated coupling

Spray gun consumables that allow easy work with gun coupled to air hose.

APP NO.	Description	Dimensions
389260	internal thread	1/4"
389262	external thread	1/4"



• APP SP-Lak System Red

System connectors for spray guns

APP SP LAK Red are four specially designer connections made of stainless steel for the correct fitting of the system cover and a cup for spray guns.

APP NO.	Description
250731	APP SP LAK System Red 1 / SATA 100, 1000, 3000, 4000, 5000
250732	APP SP LAK System Red 2 / Iwata W400
250733	APP SP LAK System Red 3 / Iwata WS400 / AZ3HTE
250734	APP SP LAK System Red 4 / DeVilbiss / APP FX1



APP 250731

APP 250732



view movie



APP 250733

APP 250734



SPRAY-PAINTING

1



Pneumatic
grinders

21-232 SPRAY-PAINTING

- 21-28 Putties and fillers
- 29-36 Base and primers
- 37-46 Top coats
- 47-56 Modular color selection system
- 57-62 Thinners, removers and additives
- 63-67 Repair of plastics
- 69-76 Adhesives and sealants
- 77-84 Car body protection and soundproofing
- 85-96 Abrasives
- 97-106 Masking systems
- 107-118 Polishing
- 119-126 OHS
- 127-132 Fabric filters and spray-painting booth accessories
- 133-154 Workshop auxiliary equipment
- 155-170 Various spray-painting products
- 171-178 Spray guns and extruders
- 179-186 • Pneumatic grinders**
- 187-192 Electric grinders, heat guns and lamps
- 193-198 Work disks
- 199-204 Dust extraction
- 205-208 Radiators
- 209-218 Pneumatics
- 219-222 Spray gun regenerators and washers
- 223-232 Technical sprays

• NTools RS

Pneumatic eccentric d150 grinders

Pneumatic vibration-rotary (eccentric) grinders with the ability to connect dust extraction are intended for continuous, high intensity work in industry and crafting. They combine high power and efficiency with low weight. The grinders are able to satisfy even the most demanding recipients.

> ADVANTAGES

- very good ergonomics and high work culture
- low level of vibrations
- acceptable noise level during work
- durable bearings and turbine blades
- high quality, non-labyrinth, Velcro-mounted d150/(14+1) MultiHole work disk adapted for dust extraction.

> PACKAGING VOLUME

- NTools RS grinder
- NTools DP15050HM (APP No. 150550) or DP15050HS (APP No 150555) work disk
- NTools ZL 2 quick connector plug
- NTools PNT 30 pneumatic tool oil
- work disk detachment key
- instruction manual and guarantee card

> TECHNICAL DATA

Working pressure	6,0-6,2 bara
Air consumption	330 l/min
Power output	0,28 hp (209 W)
Vibration frequency	up to 12000 RPM
Work disk: Velcro-fastened	d150/(14+1)h MultiHole
Work disk mounting	5/16" UNF
Air connection	1/4" NPT
Extraction hose connection	d29/35 threaded
Weight	0,85 ± 0,03 kg.
Noise	77 dBA



APP NO.	Type	Stroke	Application
135025	RS 15025	2,5 mm	for precision finishing works (P320-6000)
135050	RS 15050	5,0 mm	for broad applications in surface grinding (P80-P600)
135080	RS 15080	8,0 mm	for initial works and coarse grinding (P40-PI50)



RS 15025



RS 15050



RS 15080

• NTools AS

Pneumatic eccentric d150 grinders

The NTools AS 15025 and AS 15050 pneumatic grinders are professional tools for work in car bodywork and paint repair workshops. They combine high power and efficiency with a low weight. The grinders provide an excellently balanced ratio of durability, quality and price.

> ADVANTAGES

- very good balance
- ergonomic, rubberized handle with grooves ensuring a secure grip and comfort during extended work
- acceptable noise and vibration level
- durable bearings and turbine blades
- durable, d150/(14+1)h Velcro-fastened work disk adapted for dust extraction

> PACKAGING CONTENT

- NTools AS grinder
- NTools SP15015HM (APP No. 150517) and SP15015HS (APP No. 150518) work disk
- NTools ZL 2 quick connector plug
- dust extraction connection
- NTools PNT 30 pneumatic tool oil
- work disk detachment key
- instruction manual and guarantee card

> TECHNICAL DATA

Working pressure	6,0-6,2 bara
Air consumption	340 l/min
Power output	0,20 hp (150 W)
Vibration frequency	to12000 RPM
Work disk: Velcro-fastened	d150/(14+1)h
Work disk mounting	5/16" UNF
Air connection	1/4" NPT
Extraction hose connection	d29/35 threaded
Weight	0,87 kg
Noise	88 dBA



APP NO.	Type	Stroke	Application
136025	AS 15025	2,5 mm	for finishing works (P240-3000)
136050	AS 15050	5,0 mm	for broad applications in surface grinding (P80-P600)



AS 15025



AS 15050

• NTools PSM50

Pneumatic eccentric d50/3 grinder for small surfaces d50/3

The NTools PSM50 is a pneumatic eccentric mini-grinder intended for working in difficult to reach areas and applications in grinding edges and rims. The Velcro-fastened work disk is compatible with APP KR 50 abrasive disks.

➤ ADVANTAGES

- compact and reliable construction
- two-stage trigger
- very good balance
- acceptable noise and vibration level
- low compressed air requirement
- ergonomic, rubberized handle ensuring a secure grip, comfort and precision during extended work
- durable bearings and turbine blades
- trigger lock preventing accidental activation

➤ PACKAGING CONTENT

- NTools PSM50 grinder
- NTools TR50 Velcro (APP No. 150544) work disk
- NTools ZL 4 quick connector plug
- NTools PNT 30 pneumatic tool oil
- work disk detachment key
- instruction manual and guarantee card

➤ TECHNICAL DATA

APP NO.	139200N
Working pressure	6,0–6,3 bara
Air consumption	52,95 l/min
Vibration frequency	up to 15000 RPM
Stroke	3 mm
Work disk	d50 Velcro
Work disk mounting	5/16" UNF
Air connection	1/4" NPT
Weight	0,71 kg
Noise	87/97 dBA



• NTools PSM30

Pneumatic d30/1,5 vibration grinder for inclusion removal

The NTools PSM30 is a pneumatic mini vibration grinder designed for removing inclusions and other contamination from the surface of cured lacquer, and work with small scratches. It can be used for thorough grinding of edges and rims, and for work with difficult to reach areas.

➤ ADVANTAGES

- vibration motion with a stroke of 1,5 mm for P15000 or P2000 allows quick restoration of gloss (re-polishing) on the processed surface
- very good balance
- two-stage trigger
- low compressed air requirement
- ergonomic, rubberized handle ensuring a secure grip, comfort and precision during extended work
- low noise and vibration level
- durable bearings and turbine blades
- trigger lock preventing accidental activation
- two durable d30/M10 work disks, one fastened with adhesive, compatible with APP MX and APP PSK pads, and Velcro-fastened, for work with APP MXR Velcro pads

➤ PACKAGING CONTENT

- NTools PSM30 grinder
- two work disks: NTools TR30 Velcro (APP No. 150540) and adhesive-mounted (A)
- NTools ZL 4 quick connector plug
- NTools PNT 30 pneumatic tool oil
- instruction manual and guarantee card

➤ TECHNICAL DATA

APP NO.	139210N
Working pressure	6,0–6,2 bara
Air consumption	17,55 l/min
Vibration frequency	up to 7500 RPM
Stroke	1,5 mm
Work disk	d30 Velcro i d30 adhesive
Work disk mounting	M10
Air connection	1/4" NPT
Weight	0,87 kg
Noise	87/97 dBA



• NTools PSK

Pneumatic rotary grinder with a clamp holder for 6mm pins

The NTools PSK is a pneumatic, high-speed rotary mini-grinder designed for work on small surfaces and in difficult to reach areas during grinding metal, plastics, wood, etc. The clamp holder is compatible with d6 pins for mounting the NTools Fast Lock TM d50 work disk (APP NO. 06FLU0002).

➤ ADVANTAGES

- compact and reliable construction
- two-stage trigger
- very good balance
- acceptable noise and vibration level
- low compressed air requirement
- ergonomic, rubberized handle ensuring a secure grip, comfort and precision during extended work
- durable bearings and turbine blades
- trigger lock preventing accidental activation



➤ PACKAGING VOLUME

- NTools PSK grinder
- NTools ZL 4 quick connector plug
- NTools PNT 30 pneumatic tool oil
- two clamp holder locking keys
- instruction manual and guarantee card



➤ TECHNICAL DATA

APP NO.	139102N
Working pressure	6,0-6,3 bara
Air consumption	53,8 l/min
Rotation speed	up to 20000 rpm
Stroke	1,5 mm
Work disk mounting	clamp holder - 6 mm (1/4")
Air connection	1/4" NPT
Weight	0,63 kg
Noise level	74,5/87,5 dBA



• NTools PSRN 2

Pneumatic grinder for rust and sticker removal

NTools PSRN 2 Grinder with exhaust system purposed for removal of filler, putty, rust, stickers with flexible brush tapes which easily adapt to edges and body shape. Elements cleaned with the brushes have appearance similar to sanding effects while the cleaned surface is not deformed. Comparing to traditional abrasive disks the grinder ensures higher efficiency. The set includes: Grinder; Metal brush tape - 3 different types: Coarse - 23mm wide; d103mm; 0.5mm wire; Medium - 23mm wide; d103mm; 0.5mm wire; Finish - 23mm wide; d103mm; 0.5mm wire; 23mm brush adapter; 100mm abrasive disk along with adapter; Disk for removal of tapes and stickers along with adapter (external d103mm, and internal d30mm).

➤ ADVANTAGES

- rotational speed control throttle valve for optimal operating speed within range 0-4000 rpm
- a wide range of accessories:
 - wire wheel brushes
 - abrasive disks
 - rubberized hard disk
 that quickly remove old coats, corrosion, sprayed paints, filler, adhesive tapes and stickers, as well as emblem related glue residues.

➤ PACKAGING VOLUME

- pneumatic grinder
- coarse wire wheel brush: Width.: 23 mm; ø103 mm; wire 0,7 mm (APP No. 139933)
- fine wire wheel brush, Width.: 23 mm; ø103 mm; Wire .0.5 mm (APP No. 139935)
- abrasive disk 100 mm + adapter outer dia.. ø103 mm, inner dia.. ø30 mm (APP No. 139931)
- disk for tape and sticker removal, + adapter, outer dia.. ø103 mm, inner dia. ø30 mm (APP No. 139930)
- plastic case
- key flat
- 5/16" thread adapter - 24 turns to M4 x1 thread
- quick-coupling 1/4"
- allen key

➤ TECHNICAL DATA

APP NO.	139352P
Working pressure	6,2 bar
Air consumption	99 l/min
Rotation speed	4000 rpm
Power output	373/0,5 kW/HP
Air connection	1,4"
Noise level	104,1 dB(A)
Vibration level	1,8 m/s2
Weight	1,4 kg



• NTools PZSS

Pneumatic car windshield cutting kit

The NTools PZSS is a tool kit designed for professional and quick replacement of car windshields using blades designed and shaped specifically for that purpose. The kit features a pneumatic knife and a set of 5 blades varied in terms of size and shape. Additionally, the kit is complemented by two suction cups with a diameter of 115 mm and a belt with a clamp for pulling out and transporting the cut glass panels. The kit is packaged in a sturdy plastic carrying case.

➤ ADVANTAGES

- 5 blades varied in terms of size and shape
- stroke of 3 mm and high blade working speed up to 20000 cycles/m
- 2 articulated, two-sided suction cups with a diameter of 115 mm and a clamp for pulling out and transporting cut glass panels



➤ TECHNICAL DATA

Type	NTools PZSS
Indeks	139570N
Working pressure [bar]	6,2 bar
Air consumption [l/min]	113 l/min
Idle strokes [BPM]	20000 cykli/min
Power [kW/HP]	0,33 KM
Stroke [mm]	3 mm
Air inlet	1/4"
Air outlet	tyt
Working handle with thread	5/16"-24
Noise level: idle / operating	78 / 89 dB(A)
Knife length	195 mm
Knife weight	0,97 kg
Blades (5 pcs.)	57 / 90 / 50 / 35 / 24 mm
Suction cups (2 pcs.)	ø115 mm
Belt with buckle	4,5 m



CE

The knife (saw) is compatible with glass cutting blades available in the APP offer:

APP NO.	Product name	Length	Photo
139910*	APP ODS 1 Straight blade for glass cutting saw	57 mm	
139911*	APP ODS 2 Straight blade for glass cutting saw	90 mm	
139912	APP ODS 3 Hooked blade for glass cutting saw	18 mm	
139913	APP ODS 4 Hooked blade for glass cutting saw	36 mm	
139914	APP ODS 5 Hooked blade for glass cutting saw	60 mm	
139915	APP ODS 6 Hooked blade for glass cutting saw	90 mm	
139916*	APP ODS 7 Thin bent blade for glass cutting saw	50 mm	
139917	APP ODS 8 Straight blade for glass cutting saw	8 mm	
139918*	APP ODS 9 Straight blade for glass cutting saw	35 mm	
139919	APP ODS 10 Straight, thin, serrated blade for glass cutting saw	35 mm	
139920	APP ODS 11 Bent, thin blade for glass cutting saw	35 mm	
139921*	APP ODS 12 Hooked blade for glass cutting saw	24 mm	

* *Blades included in the NTools PZSS kit.

• NTools PW Pneumatic drill 3/8"

The NTools PW is a light, pneumatic drill designed for professional bodywork repair, workshop, industrial, assembly and carpentry works. It is suitable for extended work under heavy load, including drilling, honing and milling openings in steel, cast iron, bronze, copper, light alloys, plastics and wood. The high quality pneumatic motor ensures a low noise and vibration level. A professional, Jacobs brand self-locking drill clamp ensures a strong grip and enables easy and quick replacement of drills, cutters, or pin-mounted disks.

▶ ADVANTAGES

- efficient and simple motor construction, resistant to wear
- multi-stage planetary transmission ensures stability of rotation and the appropriate "starting" power
- self-locking Jacobs clamp enables quick replacement of drills, cutters or pin-mounted disks
- high rotary speed – the drill reaches up to 3200 rpm which makes drilling efficient and quick
- rotation direction change function (right / left) using a convenient switch by the trigger



Type	NTools PW
APP NO.	139610N
Working pressure [bar]	6,2
Air consumption [l/min]	113
Idling speed [rpm]	3.200
Power [kW/HP]	0,33
Compressed air quick connector	1/4"
Drill handle (JACOBS®)	3/8"-24
Noise level: idle/running	89 / 100
Air outlet	tyt
Length [mm]	185
Weight kg	1.15

CE



• NTools PPT Pneumatic belt file

The NTools PPT is a professional, pneumatic belt file designed for use with endless 10 x 330 mm abrasive belts. Performs great both in precision as well as coarse grinding. Thanks to its specific structure, it is perfectly suited to precise and effective grinding of tight areas such as spherical surfaces, pipes, corners, which are difficult to reach for traditional grinders. The pneumatic belt files are also an excellent solution for blunting sharp edges, and the ability to adjust the working head tilting angle provides versatility for practically any application. It is excellent for removing welds, hot-weld connections and grinding.

Type	NTools PPT
APP NO.	139300N
Pressure [bar]	6,3
Air consumption [l/min]	311
Rotational speed [RPM]	16.000
Power [kW/HP]	0,3/0,38
Air inlet	1/4"
Abrasive tape dimensions [mm]	10x330
Noise level dB(A) idle /operation	87/-
Air outlet	tyt
Length [mm]	284
Weight [kg]	0,8

CE



• NTools PNT 30 Pneumatic tool oil

Oil for pneumatic equipment, intended for lubricating the interior moving parts and sealing turbines of pneumatically powered devices. Manufactured from a high-quality oil base with the addition of performance chemicals.

▶ ADVANTAGES

- good adhesion to the lubricated surface
- no reaction with structural materials (aluminum, steel, rubber and plastic seals)
- good resistance to aging (sludge deposits on moving parts over a long period of exploitation)

▶ TECHNICAL DATA

APP NO.	389400
Volume	30 ml
Kinematic viscosity at a temperature	+40°C: 31,2 mm²/s
Density at +20°C	0,883 g/cm³
Flow temperature	-18°C
Ignition temperature	+184°C



- **NTools ZL 2**

EURO DN 7,2 quick connector plug
with a z G 1/4" external thread, brass

A quick connector plug with a standard EURO DN 7,2 profile with a cylindrical, external G 1/4" thread. Made from brass. Intended for pneumatic grinders.

Compatibility: RECTUS 26, RECTUS 25, RECTUS 1600/1625 TEMA 1600, CEJN 320, JWL 520 + JWL 530 and other German products.



APP NO.	Description
389258	external thread 1/4"

SPRAY-PAINTING

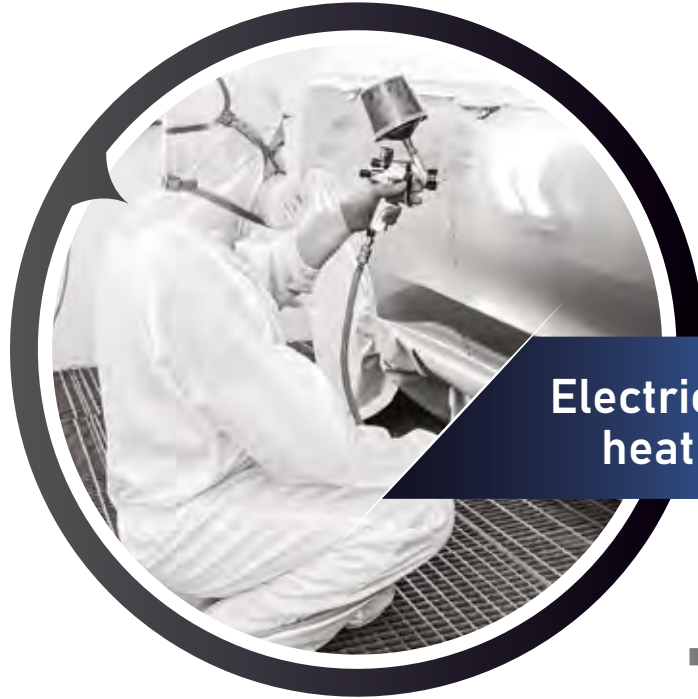

Electric grinders,
heat guns and lamps

21-232 SPRAY-PAINTING

- 21-28 Putties and fillers
- 29-36 Base and primers
- 37-46 Top coats
- 47-56 Modular color selection system
- 57-62 Thinners, removers and additives
- 63-67 Repair of plastics
- 69-76 Adhesives and sealants
- 77-84 Car body protection and soundproofing
- 85-96 Abrasives
- 97-106 Masking systems
- 107-118 Polishing
- 119-126 OHS
- 127-132 Fabric filters and spray-painting booth accessories
- 133-154 Workshop auxiliary equipment
- 155-170 Various spray-painting products
- 171-178 Spray guns and extruders
- 179-186 Pneumatic grinders
- 187-192 • Electric grinders, heat guns and lamps**
- 193-198 Work disks
- 199-204 Dust extraction
- 205-208 Radiators
- 209-218 Pneumatics
- 219-222 Spray gun regenerators and washers
- 223-232 Technical sprays

• NTools ROS

Brushless electric d150 eccentric grinders

Electric, brushless, vibration-rotary (eccentric) grinders with the ability of connecting dust extraction, intended to medium intensity work in industry and crafting. They combine high power, high efficiency, and low weight. The grinders are able to satisfy the requirements of even the most demanding customer.

➤ ADVANTAGES

- airtight, 350W motor ensures maximum stability and control of the tool during work
- minor impact of changes in rotational speed on the change in torque
- lower susceptibility to decreases in power supply voltage in relation to classic grinders
- built in electronic commutator featuring a speed regulation mfomule with a soft start, allows to smooth start-up and maintenance of stable rotational speed in a range from 4000 to 10000 rpm
- very gofrom ergonomics and high work culture
- very low noise and vibration level during operation
- high durability and reliability and a long interval between inspections
- high quality, universal, Velcro-fastened d150/(14+1/16+1)h work disk adapted to dust extraction
- device compatible with dust extraction and equipped with a connection to 35mm diameter extraction hoses (NTools VC 50E/EP, Rupes, etc.)
- flexible, silicone power supply cable with a length of 5 m

➤ PACKAGING VOLUME

- NTools ROS grinder
- NTools SPM 150 15/17 HU M work disk (APP No. 150075)
- Work disk detachment key
- NTools ADO 50 extraction hose connector (APP No. 600012ND)
- Instruction manual and guarantee card

➤ TECHNICAL DATA

APP NO.	125002	125005
Type	ROS 02E	ROS 05E
Application	to precise finishing works (P320-6000)	to broad applications in surface grinding (P80-P600)
Power supply voltage	230 V / 50 Hz	230 V / 50 Hz
Power consumption	350 W	350 W
Rotational speed	from 4000 to 10000 RPM	from 4000 to 10000 RPM
Electronic speed regulation	YES	YES
Stroke	2,5 mm	5 mm
Work disk	Velcro-fastened, d150/(14+1/16+1)h	Velcro-fastened, d150/(14+1/16+1)h
Work disk mounting	max d29/35 threaded	max d29/35 threaded
Carbon brushes	none	none
Power supply cable length	5 m	5 m
Weight	1,5 kg	1,5 kg

CE



ROS 02E



ROS 05E

• NTools RP 150E Pro

Rotary electric polisher with smooth rotational speed adjustment

NTools RP 150E Pro is a rotary electric polisher equipped with an efficient 1000W motor with an electronic rotation regulation and stabilization mfomule. It features soft start-up and 6-step speed adjustment in a range of 800 – 3300 rpm. The polisher is equipped with a 125 mm Velcro work disk mounted on an M14 thread.

➤ ADVANTAGES

- excellent balancing, low vibrations and a light and ergonomic construction guarantee comtot during extended work
- electronic rotation speed stabilization guarantees maintenance of a constant work speed during polishing under variable load
- 6-step speed adjustment with a soft start enables smooth speed adjustment under load during work, within a range from 800 to 3300 rpm
- rubberized frame elements improve grip during extended polishing and protect the tool against accidental damage
- a 4 meter power supply cable ensures freedom of movement at the workstation without the need to use additional extension cords
- high quality Velcro work disk with a diameter of 125 mm

➤ PACKAGING VOLUME

- NTools RP 150E Pro rotary polisher
- d125/M14 Velcro work disk
- "D" type working handle with mounting screws
- hex key
- additional carbon brushes
- transport bag
- instruction manual and guarantee card

➤ TECHNICAL DATA

APP NO.	126010
Power supply voltage	230 V / 50 Hz
Power consumption	1000 W
Rotational speed	from 800 to 3300 RPM
Electronic speed regulation	YES
Soft start	YES
Side handle	NO
Spindle lock	NO
Work disk mounting	M14
Carbon brushes	APP NO. 600072
Max polishing pad diameter	150 mm
Power supply cable length	4 m
Weight	2,5 kg

CE



! Every polisher is packaged in a functional and strong, zipper closed bag featuring 6 interior and 8 exterior pockets that will hold the polisher and arrange the polishing pads and pastes, microfiber cloths and other accessories essential during polishing works.

• NTools DAP II

Eccentric Dual Action type electric polishers DAP II 15E and DAP II 21E

NTools DAP II are eccentric Dual Action type electrical polishers with a 15 and 21 mm stroke. They are intended to polishing of all types of surfaces and removing holograms.

- The DAP II 15E polisher features a 15 mm stroke, a ventilated, 8 hole, 125 mm diameter, Velcro work disk mounted on a wedge and 5/16" UNF screw, and is designed to working with pads from 125 to 150 mm in diameter

- The DAP II 21E polisher features a 21 mm stroke, a ventilated, 14+1 hole, 150 mm diameter Velcro work disk mounted on a wedge and 5/16" UNF screw, and is designed to working with pads from 150 to 180 mm in diameter.

► TECHNICAL DATA



Power supply voltage	230 V / 50 Hz
Power consumption	1000 W
Rotational speed	from 2200 to 5000 RPM
Electronic speed regulation	YES
Stroke	15 mm for DAP II 15E lub 21 mm for DAP II 21E
Work disk	velcro, d125/8h for DAP II 15E and d150 / (14+1)h for DAP II 21E
Work disk mounting	wedge and 5/16" UNF screw
Carbon brushes	APP NO. 600072
Power supply cable length	5 m
Weight	2,5 kg for DAP II 15E and 2,6 kg for DAP II 21E

APP NO.	Type	Stroke
126004	DAP II 15E	15 mm
126009	DAP II 21E	21 mm

► PACKAGING VOLUME

- NTools DAP II eccentric polisher,
- d125/8h Velcro work disk for DAP II 15E,
- d150/(14+1)h Velcro work disk for DAP II 21E,
- "D" type work handle with mounting screws,
- hex key,
- additional carbon brushes,
- transport bag,
- instruction manual and guarantee card.



DAP II 21E



DAP II 15E



advantages ✓

- 01 eccentric motion combined with a large stroke (grinding stroke) allows to effectively remove scratches and holograms within one work stage
- 02 electronic, 6-step speed control module enables a soft start, smooth rotational speed adjustment under load during work.
- 03 the rotational speed regulator in the on switch enables smooth speed adjustment when moved from zero to the speed set on the rotational speed regulator.
- 04 the device's low weight does not fatigue the arms during extended work
- 05 the 5 meter power supply cable ensures freedom of movement at the workstation without the need to use additional extension cords

• NTools RP II 180E

Electric rotary polisher with smooth speed adjustment

The NTools RP II 180E is the second generation of the full-sized, electric rotary polisher with work disk mounting on an M14 thread. It features a powerful 1400W motor and electronic rotational speed stabilizer that ensures maintenance of a constant speed at variable load. After applying the appropriate paste, pad or wool, it can be used to remove scratches and add gloss to any type of surface.

➤ ADVANTAGES

- high power and electronic stabilization ensure stable and even operation of the device during polishing under variable load, even at the lowest rotational speed setting
- the electronic speed regulation module with a soft water enables smooth speed change during work within a range from 500 to 3000 rpm
- a long, 5 meter, flexible, silicone power supply cable ensures freedom of movement at the workstation without the need to use additional extension cords
- additional guards ensure work safety and protect against dust accessing the polisher's frame interior

➤ PACKAGING VOLUME

- NTools RP 180E rotary polisher
- d150/M14 polishing pad
- Side work handle
- Additional carbon brushes
- Instruction manual and guarantee card

➤ TECHNICAL DATA

APP NO.	126002
Power supply voltage	230 V / 50 Hz
Power consumption	1400 W
Rotational speed	from 500 to 3000 RPM
Electronic speed regulation	YES
Soft start	YES
Side work handle	YES
„D“ type work grip with mounting screws	NO (can be bought separately)
Spindle lock	YES
Velcro-fastened work disk	NO
Work disk mounting	M14
Carbon brushes	APP NO. 600001
Max polishing pad diameter	150 mm
Power supply cable length	5 m
Weight	3,2 kg



CE



• NTools HG LCD

Heat gun with electronic temperature adjustment and LCD display

NTools HG LCD 2000 W electric heat gun with smooth, electronic temperature adjustment in a range from 50°C do 600°C and step air flow adjustment in a range from 120 L/min to 500 L/min. It is characterized by an aesthetic and modern design, ergonomic frame and ease of use. The heat gun features an LCD display that indicates the selected temperature and air flow strength. Additionally, it has a cooling function – when the switch is set to the “I” position (constant temp. of 50°C), and the ability to switch the temperature units °C/F. The NTools HG LCD heat gun is used for heating, searing, defrosting, drying, removing stickers and old paint coats, heating up seared threaded connection in order to facilitate their unscrewing, application of edge veneers, shrinking of heat-shrink covers, etc.

APP NO.	Description
126008	Heat gun with electronic temperature adjustment and LCD display



• NTools HG LED

Heat gun with temperature adjustment and LED display

The NTools HG LED 2000 W electric heat gun with a temperature range from 50°C do 600°C and step air flow adjustment between 250 L/min to 550 L/min is characterized by an aesthetic and modern design, ergonomic frame and ease of use. The heat gun features a 6-diode temperature indicator and three-position switch allowing to choose one of two temperature and blown air flow ranges. The NTools HG LED heat gun is used for heating, searing, defrosting, drying, removing stickers and old paint coats, heating up seared threaded connection in order to facilitate their unscrewing, application of edge veneers, shrinking of heat-shrink covers, etc.

APP NO.	Description
126007	Heat gun with temperature adjustment and LED display



• NTools Colour Check 4500

Paint inspection lamp

The NTools Colour Check 4500 is a modern inspection lamp designed for identifying colors, color inspection after lacquering, and inspection of lacquering coats after polishing. The lamp is an essential tool in paint repair workshops and detailing studios, which perform spray-painting and polishing works. The NTools Colour Check 4500 lamp is resistant to shocks and water.



► TECHNICAL DATA

APP NO.	171110
Light source	5W COB Led
Color rendering factor	CRI > 95
Light color temperature	4500 K
Luminous flux	400 / 200 lm (mode 1/mode 2)
Protection rating	IP65
Mechanical strength	IK07
Battery capacity	3.7V 2600mAh Li-ion
AC adapter	5V 1.0A + cable USB 1,5 m
Weight	310 g
Dimensions	190x56x29 mm

• NTools L COB 400

Battery powered LED workshop lamp

The NTools L COB 400 work lamp is a modern lamp that constitutes an essential tool in any workshop. The unique method of LED placement forms the NTools sign which in its entirety provides a uniform light beam. The color temperature is similar to daylight at noon.



► ADVANTAGES

- Luminous flux in three modes: 400 lm (mode 1), 200 lm (mode 2), 100 lm (mode 3)
- Light color temperature 5500 K
- High capacity 2000 mAh battery
- Quick charging in 2,5 h
- Hanger 360°

APP NO.	Description
171111	Battery powered LED workshop lamp

SPRAY-PAINTING



Work disks

21-232 SPRAY-PAINTING

- 21-28 Putties and fillers
- 29-36 Base and primers
- 37-46 Top coats
- 47-56 Modular color selection system
- 57-62 Thinners, removers and additives
- 63-67 Repair of plastics
- 69-76 Adhesives and sealants
- 77-84 Car body protection and soundproofing
- 85-96 Abrasives
- 97-106 Masking systems
- 107-118 Polishing
- 119-126 OHS
- 127-132 Fabric filters and spray-painting booth accessories
- 133-154 Workshop auxiliary equipment
- 155-170 Various spray-painting products
- 171-178 Spray guns and extruders
- 179-186 Pneumatic grinders
- 187-192 Electric grinders, heat guns and lamps
- 193-198 • Work disks**
- 199-204 Dust extraction
- 205-208 Radiators
- 209-218 Pneumatics
- 219-222 Spray gun regenerators and washers
- 223-232 Technical sprays

• **NTools SPM 150 15/17HU M**
Velcro work disk with a universal hole configuration d150/(15/17)h 5/16" UNF



NTools SPM 150 15/17HU M work disk with a universal hole configuration, with a diameter of 150 mm, with durable, low Velcro. Made from a hard and elastic, yellow colored PU foam with a thickness of 10 mm, with a riveted on screw with a 5/16" UNF thread. It is designed for compatibility with NTools ROS 02E/05E grinders and as a substitute for Deros grinders by Mirka, NTools RS and NTools AS pneumatic grinders, and others with work disk mounting on a 5/16" UNF thread. It is adapted for work with Velcro fastened, 150 mm diameter abrasive disks with an asymmetrical 8+6+1=14+1=15 (e.g. Quartz, HMF7) or symmetrical 8+8+1=16+1=17 hole configuration (e.g. Festool, Makita). Low, professional Velcro ensures very minor deflection and excellent grip of the abrasive disks, guaranteeing precise finishing of the processed surface.



APP NO.	Type	Size
150575	hard	d150

• **NTools DP 15050HM i NTools DP 15050HS**
Velcro work disks d150/(14+1)h 5/16" UNF

The non-labyrinth work disks NTools DP 15050HM and NTools DP 15050HS with a 5/16" UNF fastening are intended for work with Velcro abrasive disks with 6, 6+1, 8+1, 14+1 dust extraction holes, multi-hole disks and abrasive meshes.

➤ **WORK DISK CONSTRUCTION**

- laminated fiberglass and epoxy resin core with a riveted on steel connector guarantee high stability and reliability
- non-labyrinth, urethane, short and hard work surface for DP 15050HM and soft, taller for DP 15050HS ensure maximum effectiveness in dust extraction
- short Velcro with increased mechanical strength and thermal resistance
- fastening of the work disk to the machine takes place using a built-in steel bolt with a 5/16" UNF thread

The disks are designed for use with NTools RS, Dynabrade Supreme, MIRKA (ROS, CEROS), 3M (PN20461, PN28508) grinders and all other grinders with a broad extraction flange and disk mounting using a 5/16" UNF thread.

APP NO.	Type	Size	Fastening
150550	hard	d150	5/16"
150555	soft	d150	5/16"



DP 15050HM



DP 15050HS

• **NTools SP 15015HM i NTools SP 15015HS**
Velcro work disks d150/(14+1)h 5/16" UNF

The NTools SP 15015HM and NTools SP 15015HS work disks with a 5/16" UNF fastening are designed for work with Velcro abrasive disks with 6, 6+1, 8+1, 14+1 extraction holes, and with abrasive meshes.

➤ **WORK DISK CONSTRUCTION**

- laminated fiberglass and epoxy resin core with a riveted on steel connector guarantee high stability and reliability
- polyurethane (PU) work surface, hard and short for SP 15015HM and tall for DP 15050HS
- Velcro with increased grip and mechanical strength
- fastening of the work disk to the machine takes place using a built-in steel bolt with a 5/16" UNF thread

The NTools SP 15015HM and NTools SP 15015HS work disks with 5/16" UNF fastening are designed for work with Velcro abrasive disks with 6, 6+1, 8+1, 14+1 extraction holes, and mesh disks.

APP NO.	Type	Size	Fastening
150517	thin	d150	5/16"
150518	thick	d150	5/16"



SP 15015HM



SP 15015HS

• APP TR PL

Velcro work disk d150/(6+1)h for grinders and planetary (gear driven) polishers with 6 x M4 screw fastening

The APP TR PL work disk mounted on six M4 screws is designed for working with Velcro abrasive pads d150 with 6 or 6+1 extraction holes. When using the NTools PS 150 (APP no. 150561) protective spacer, it is possible to use Velcro abrasive pads with 14+1 extraction holes. It is also possible to use Velcro polishing pads > d150 for working on geared polishers. The disks are designed for use with planetary grinders like Rupes EK150AES and AK150A, as well as gear driven polishers, e.g. Rupes LK900E.

APP NO.	Type	Size	Fastening
150500	hard	d150	6 x M4



• NTools TR 150U i TR 125U

Velcro work disks d150/(14+1)h and d125/(8+1)h for DAP eccentric grinders and polishers with a groove and M8 or 5/16" UNF screw mounting

The NTools TR 150U and TR 125U work disks mounted with a groove and M8 or 5/16" UNF screws are designed for work with d150 Velcro abrasive disks with 6, 6+1, 8+1, 14+1 extraction holes and > d150 pads for the TR 150U with a diameter of 150 mm and d125 with 8+1 extraction holes, and > d125 pads for the TR 125U disk with a diameter of 125 mm.

➤ WORK DISK CONSTRUCTION

- laminated fiberglass and epoxy resin core with a riveted on steel connector and a steel locking groove insert guarantee high stability and reliability
- polyurethane (PU) work surface
- Velcro with increased grip and mechanical strength
- fastening of the work disk to the tool takes place using a groove insert and a steel screw with an M8 thread or a screw with a 5/16" UNF thread

The disks are designed for use eccentric grinders and polishers like NTools DAP I and II; RUPES (LHR21, LHR15; SKORPIO I, II, III; ER03/05TE; ER155TE; BR106/109/112AES); FESTOOL (ETS150 and 125), MAKITA B06030 and all other tools with a groove and M8 or 5/16" UNF screw disk mount.

APP NO.	Fastening	Size
150509	inlet + M8 & 5/16"	d150
150508	inlet + M8 & 5/16"	d125



TR 150U



TR 125U

• NTools TR 150 15/17U

Velcro work disks d150/(15/17)h, for a HEX inlet and M8 or 5/16" UNF screw

The NTools TR 15015/17U work disks mounted on a HEX inlet and M8 or 5/16" UNF screws for attaching Velcro abrasive pads with a diameter of 150 mm with 14+1 or 16+1 extraction holes. Intended for work with NTools SWR 03E and NTools SWR 05E grinders.

APP NO.	Fastening	Size
150570	inlet + M8 & 5/16"	d150



• NTools TR 30

Velcro or adhesive fastened d30/M10 work disks

Works disks with a diameter of 30 mm, mounted on an M10 thread with Velcro or for attaching sandpaper with adhesive. Designed for work with NTools PSM30, NTS SA 4115P and RUPES LD 30 grinders.

APP NO.	Type	Size	Fastening
150542	adhesive	d30	M 10
150540	Velcro	d30	M 10



• NTools TR 50

d50 5/16" UNF Velcro work disk

A Velcro work disk with a diameter of 50 mm, mounted on a 5/16" UNF thread, for Velcro fastening of 50 mm diameter sandpaper without holes. Designed for work with the NTools PSM50 grinder.

APP NO.	Fastening	Size
150544	thread + 5/16"	d50



• NTools Fast LOCK TM

6 mm mounting plate with pin

Elastic support plate with a diameter of 50 mm with a quick fastening system for the abrasive material. It features a mounting pin with a diameter of 1/4" (6 mm) designed for clamping holders of high-speed rotary grinders, e.g. NTools PSK.

➤ ADVANTAGES

- one grip for many abrasive tools ensuring very quick replacement
- unified quick fastening system thread
- system compatible with the 3M Roloc and the Norton SpeedLok TR systems
- maximum rotational speed: 30 000 RPM

APP NO.	Col. pack.	Size
06FLU0002	2 pcs.	d50
06FLU0002B	25 pcs.	d50



• APP Turbo

Fiber pad support plate with an M14 nut

Support plate for mounting fiber pads, designed for coarse and finishing grinding. The TURBO support plate features ribbing that reduces the temperature generated when grinding, significantly impacting the abrasive material's durability. It features an M14 fastening nut. The maximum working speed is 80 m/s.

➤ ADVANTAGES

- reduces temperature generated during grinding
- lower risk of overheating the processed material
- longer durability of the fiber pad

APP NO.	Size
150531	d125



• NTools PS 150

Protective spacer for a d150 Velcro, 14+1 hole MultiHole work disk

A very thin protective spacer from bonded Velcro, compatible with Velcro-fastened work disks d150 with 6+1, 8+1 and 14+1 extraction holes. It protects the working disk's Velcro against mechanical and thermal damage. Reduces vibrations transferred to the grinding technician's arms.

APP NO.	Size	Col. pack.
150560	d150	10 pcs.
150561	d150	1 pcs.

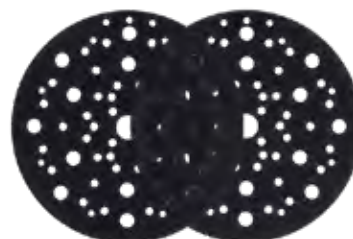



• NTools PMG06 MR

Soft, micro rubber spacer, d150/h3 Velcro, 14+1 holes

Soft micro rubber spacer, fastened with micro-Velcro with a diameter of d150, thickness of 3 mm, and 14+1 holes, designed for adapting abrasive disks to the shapes of processed objects during finishing grinding of surfaces using eccentric grinders, e.g. before polishing.

➤ ADVANTAGES

- allows to obtain a uniform surface with complex shapes
- evens out the pressure of sandpaper on the processed surface
- by minimizing "Velcro deflection", it increases the precision of inclusion removal on cured lacquer surfaces
- protects the work disk
- limits vibrations transferred onto the grinding technician's arms

APP NO.	Thickness	Size
06PM0001	3 mm	d150



• NTools PMG06 SR

Soft, micro rubber spacer, d150/h6 Velcro, 14+1 holes

Soft micro rubber spacer, fastened with Velcro with a diameter of d150, thickness of 6 mm, and 14+1 holes, designed for adapting abrasive disks to the shapes of processed objects during finishing grinding of surfaces using eccentric grinders. Intended for finishing works.

➤ ADVANTAGES

- allows to obtain a uniform surface with complex shapes
- evens out the pressure of sandpaper on the processed surface
- protects the work disk
- limits vibrations transferred onto the grinding technician's arms

APP NO.	Thickness	Size
06PM0002	6 mm	d150



• NTools PNM

Soft PU foam spacer, d150/h12 Velcro, 14+1 holes

A spacer from very soft PU foam, fastened with Velcro, with a diameter of d150, thickness of 12 mm, and 14+1 holes, designed for adapting abrasive disks to the shapes of processed objects during finishing grinding of surfaces using eccentric grinders.

➤ ADVANTAGES

- allows to obtain a uniform surface with complex shapes
- evens out the pressure of sandpaper on the processed surface

APP NO.	Thickness	Size
06PN0001	12 mm	d150



• APP RS 150

Self-adhesive Velcro for work disks

Self-adhesive Velcro pads for work disks with a diameter of 150 mm, with 14+1 holes and without holes.

APP NO.	Type	Size
250651	14+1 holes	d150
250652	no holes	d150



SPRAY-PAINTING



Dust extraction

21-232 SPRAY-PAINTING

- 21-28 Putties and fillers
- 29-36 Base and primers
- 37-46 Top coats
- 47-56 Modular color selection system
- 57-62 Thinners, removers and additives
- 63-67 Repair of plastics
- 69-76 Adhesives and sealants
- 77-84 Car body protection and soundproofing
- 85-96 Abrasives
- 97-106 Masking systems
- 107-118 Polishing
- 119-126 OHS
- 127-132 Fabric filters and spray-painting booth accessories
- 133-154 Workshop auxiliary equipment
- 155-170 Various spray-painting products
- 171-178 Spray guns and extruders
- 179-186 Pneumatic grinders
- 187-192 Electric grinders, heat guns and lamps
- 193-198 Work disks
- 199-204 • Dust extraction**
- 205-208 Radiators
- 209-218 Pneumatics
- 219-222 Spray gun regenerators and washers
- 223-232 Technical sprays

• NTools VC 50EP

Dust extractor with automated electric-pneumatic activation



The NTools VC 50EP mobile dust extractor is designed for extraction of grinding dust in a paint and bodywork repair shop, during production of furniture, at construction sites and during works involving pneumatic and electric power-tools. The extractor can be used during grinding, milling, cutting and drilling – dry, as well as wet, after prior removal of the paper bag. The extractor features two operating modes: manual and automatic. In automatic mode, the extractor engages after activation of the pneumatic or electric tool, and deactivates with a delay from 3 to 5 seconds after its disengagement. The electric socket in the upper panel of the extractor can supply single phase power to an electric tool, with a maximum output power of 2000 W. The pneumatic connectors with a standard EURO 7,2 profile are compatible with RECTUS 26KA. The extractor's electric connection automation cooperates with the NTools ROS brushless, electric grinders in the full range of their speed adjustment.

➤ EXTRACTOR ACCESSORIES

- 2in1 spiral hose (d29/35 + d7,5/10) with connectors and a length of 5 m, compatible with pneumatic grinders
- NTools WFP 60 disposable paper dust bag
- NTools FM 50 fabric filter with steel frame
- foam filter mounted on the wet work floater casing

➤ TECHNICAL DATA

Power supply voltage - 230V / 50Hz
 Power consumption - 1400 W
 Vacuum - 20500 Pa
 Air flow - 38 l/s
 Container capacity - 50 L
 Electric automation - YES
 Pneumatic automation - YES

APP NO.	Description
140020	Dust extractor with automated electric-pneumatic activation



• NTools VC 50E

Dust extractor with automated electric activation



The NTools VC 50E mobile dust extractor is designed for extraction of grinding dust in a paint and bodywork repair shop, during production of furniture, at construction sites and during works involving pneumatic and electric power-tools. The extractor can be used during grinding, milling, cutting and drilling – dry, as well as wet, after prior removal of the paper bag. The extractor features two operating modes: manual and automatic. In automatic mode, the extractor engages after activation of the pneumatic or electric tool, and deactivates with a delay from 3 to 5 seconds after its disengagement. The electric socket in the upper panel of the extractor can supply single phase power to an electric tool, with a maximum output power of 2000 W. The extractor's electric connection automation cooperates with the NTools ROS brushless, electric grinders in the full range of their speed adjustment.

➤ EXTRACTOR ACCESSORIES

- d29/35 spiral hose with a length of 5 m, compatible with electric grinders
- NTools WFP 60 disposable paper dust bag
- NTools FM 50 fabric filter with steel frame
- foam filter mounted on the wet work floater casing

➤ TECHNICAL DATA

Power supply voltage - 230V / 50Hz
 Power consumption - 1400 W
 Vacuum - 20500 Pa
 Air flow - 38 l/s
 Container capacity - 50 L
 Electric automation - YES
 Pneumatic automation - NO

APP NO.	Description
140015	Dust extractor with automated electric activation



! Single-user device.

• NTools VC 30Eco

Dust extractor with automated electric on/off switch

Mobile dust extractor for workshop applications, with dry and wet vacuuming function.

➤ ADVANTAGES

- integrated socket compatible with electric power-tools, with an automated on / off function
- strong and highly efficient motor
- 30 L steel dust container
- 4 m long extraction hose

The extractor is additionally equipped with: a round brush, nozzles for wet floors, carpets, a narrow gap nozzle for difficult to reach surfaces

APP NO.	Description
140001	Dust extractor with automated electric on/off switch

! Single-user device

CE



• NTools WFM 50

Fabric dust bag for the NTools VC 50E/EP dust extractors

A reusable, 50L capacity fabric bag for the NTools VC 50E/ EP dust extractor with automated electric on/off switch. The polypropylene (PP) nonwoven fabric bag is sewn with a textile thread with stitching on the interior. The upper part features an inlet hole with a 58 mm diameter, with a rubber seal fastened in a square, plastic bracket with dimensions of 94 x 94 mm. The bottom part features a hole for removing the accumulated dust, secured with a sliding, plastic zip lock strip.

APP NO.	Color	Size	Sales units
600099	grey	50 L	5 pcs.
8600099	grey	50 L	pack 5 pcs.



• NTools WFP 60

Paper filtering bag for NTools VC 50E/EP, VC36E/EP dust extractors

A paper filtering bag with a 60 L capacity for gathering dust in the NTools VC 50E/EP dust extractors.

➤ CONSTRUCTION

- dual-layer paper glued with a special adhesive increasing the bag's durability
- inlet hole with a diameter of 58 mm, with a rubber seal preventing the dust from escaping into the extractor's container
- 60 L capacity, dimensions 700 mm x 400 mm

APP NO.	Color	Size	Sales units
600005	brown	60 L	1 pcs.
8600005	brown	60 L	pack 5 pcs.



• NTools WFM 30

Fabric dust for the bag NTools VC 30Eco dust extractor

A reusable, 30L capacity fabric bag for the NTools VC 30Eco dust extractor with automated electric on/off switch. The polypropylene (PP) nonwoven fabric bag is sewn with a textile thread with stitching on the interior. The upper part features an inlet hole with a 52 mm diameter, with a rubber seal fastened in a square, plastic bracket with dimensions of 93 x 93 mm. The bottom part features a hole for removing the accumulated dust, secured with a sliding, plastic zip lock strip.

APP NO.	Color	Size	Sales units
600039	grey	30 L	pcs.
8600039	grey	30 L	pack 5 pcs.



• NTools WF 30

Paper filtering bag for VC 30Eco

A paper filtering bag with a 30 L capacity for gathering dust in the NTools VC 30Eco dust extractors.

> CONSTRUCTION

- dual-layer paper glued with a special adhesive increasing the bag's durability
- inlet hole with a diameter of 52 mm, with a rubber seal preventing the dust from escaping into the extractor's container
- 30 L capacity, dimensions 550 mm x 350 mm

APP NO.	Color	Size	Sales units
600017	brown	30 L	1 pcs.
8600017	brown	30 L	pack 5 pcs.



• NTools FH 30/50

Main HEPA filter for VC 30Eco and VC 50E/EP

A HEPA filter for the VC 30Eco dust extractor, ensuring additional protection of the motor during dust extraction.

APP NO.	Description
600011	Main HEPA filter for VC 30Eco and VC 50E/EP



• NTools FM 50

Fabric filter for VC 30Eco

The NTools FM 50 is a reusable fabric filter for the NTools VC 50E and NTools VC 50EP dust extractors, that protects their motors against dust build up and damage. The NTools FM 50 fabric filter, together with the paper dust bag, form a double filtration system in which the dust sucked into the dust extractor's container is prevented from accessing the motor chamber. The fabric filter and steel wire frame is designed for repeated use.

APP NO.	Description
600021	Main fabric filter for VC 50E/EP



• NTools FM 30

Fabric filter for VC 30Eco

The fabric filter for the VC 30Eco dust extractor constitutes the extractor's basic equipment. It serves as the motor's primary protection measure against dust and water.

APP NO.	Description
600010	Fabric filter for VC 30Eco



• NTools WOP 5

2w1 hose for pneumatic dust extractors + zipped bag

A 2w1 suction hose with pneumatics, with a length of 5 m and an internal diameter of 29 mm and external diameter of 35 mm, designed for use with electric and pneumatic dust extractors: NTools VC 50EP and Rupes S130PL, S145EPL, KS260EPNS, S235EP. The hose features an integrated compressed air conduit and a quick connector with a nozzle, and rubber tips for connecting grinders adapted for dust extraction.

APP NO.	Description	Size
600022	d29/35	5 m



• NTools WOE 5

Hose for pneumatic dust extractors + zipped bag

The NTools WOE 5 is a 5 m long suction hose with an internal diameter of 29 mm and external diameter of 35 mm designed for use with electric dust extractors: NTools VC 50E and Rupes S130L, S145EL, KS260EN, S235E. The hose features rubber tips for connecting grinders and other electric tools adapted for dust extraction.

APP NO.	Description	Size
600023	d29/35	4,5 m



• NTools WO 30

Vacuuming hose with nozzles, d32mm / 4m VC 30Eco

A vacuuming hose with a tip that enables connection of various nozzles. Compatible with the VC 30Eco dust extractor.

APP NO.	Description	Size
600013	d32	4 m



• NTools ZO VC50

5in1 set of vacuuming accessories for the NTools VC50E/EP dust extractor + zipped bag

A 5in1 set of accessories for the NTools VC50E/EP dust extractor, packaged in a very durable and damage resistant nylon bag with a zipper.

APP NO.	Description
600026	5in1 set of vacuuming accessories for the NTools VC50E/EP dust extractor + zipped bag



• NTools KWO

Tip for a d29 suction hosed for NTools/Rupes dust extractors

Elastic, rubber top for a 29 mm diameter suction hose, compatible with suction hoses for NTools VC 50E/ EP and Rupes dust extractors.

APP NO.	Description	Application
600024	d29	NTools VC 50E/EP Rupes



• NTools RS 150

Plug in adapter for hose to grinder connection

A plug in connector with a diameter of 29 mm (adapter) for NTools RS 150 grinders, screwed in to the outlet of the dust extraction channel in order to connect with the NTools KWO rubber connector and others of a similar type.

APP NO.	Description	Application
600032	d29	NTools RS 150



• NTools ADO 50

Adapter for connection electric and pneumatic equipment with dust extraction hoses

NTools ADO 50 is an adapter for connecting a dust extraction system to electric and pneumatic equipment. It is made from elastic rubber with a thickness of approx. 3 mm. It consists of 5 cylindrical segments with diameters ranging from 23 to 50 mm, allowing to connect suction hoses to many different grinder models with a dust extraction option. The three widest adapter segments feature an internal thread compatible with hoses for NTools VC 30Eco, NTools VC50 E/EP and Rupes, Festool and many other dust extractors.

► Internal diameters of individual adapter segments:

1. \varnothing 23 mm
2. \varnothing 32 mm
3. \varnothing 34 mm (internal thread)
4. \varnothing 38 mm (internal thread)
5. \varnothing 50 mm (internal thread)

APP NO.	Compatible with
600012ND	NTools VC 30Eco, NTools VC50 E/EP and Rupes, Festool



SPRAY-PAINTING

1



Radiators

21-232 SPRAY-PAINTING

- 21-28 Putties and fillers
- 29-36 Base and primers
- 37-46 Top coats
- 47-56 Modular color selection system
- 57-62 Thinners, removers and additives
- 63-67 Repair of plastics
- 69-76 Adhesives and sealants
- 77-84 Car body protection and soundproofing
- 85-96 Abrasives
- 97-106 Masking systems
- 107-118 Polishing
- 119-126 OHS
- 127-132 Fabric filters and spray-painting booth accessories
- 133-154 Workshop auxiliary equipment
- 155-170 Various spray-painting products
- 171-178 Spray guns and extruders
- 179-186 Pneumatic grinders
- 187-192 Electric grinders, heat guns and lamps
- 193-198 Work disks
- 199-204 Dust extraction
- 205-208 • Radiators**
- 209-218 Pneumatics
- 219-222 Spray gun regenerators and washers
- 223-232 Technical sprays

• NTools FDS 6600

6 x 1,1 kW radiator with timed off-switch and power adjustment, on an extension arm

The NTools FDS 6600 infrared radiator with a timed off-switch and power adjustment is equipped with six lamps with an output power of 1100 W each and an electronic control panel. The extension arm with a telescopic lock enables drying of corners, horizontal surfaces, such as roofs and engine and trunk covers, and vertical surfaces. The radiator emits short-wave, infrared rays. Lamp color – red (ruby).



> ADVANTAGES

- full control over the operating time and generated power
- pulse or constant operation mode
- significantly reduces the drying time of all types of spray-painting and lacquering products
- effectively heats only the repaired area
- temperature increment begins from the metal to the surface of the dried layer
- the infrared wave energy passes through air nearly without losses and immediately affects the repaired area

> TECHNICAL DATA

Voltage: 2 x 230V / 50Hz
 Max power consumption: 6600 W
 Power adjustment: from 35% to 100%
 Time adjustment: from 1 to 99 min.
 Dried surface area: 1800 x 1000 mm



APP NO.	Description
190283	6 x 1,1 kW radiator with timed off-switch and power adjustment on an extension arm



• NTools FDS 3300

3 x 1,1 kW radiator with timed off-switch and power adjustment, on an extension arm

The NTools FDS 3300 infrared radiator features three 1100 W power lamps and an electronic control panel. The extension arm with a telescopic lock enables drying of corners, horizontal surfaces, such as roofs and engine and trunk covers, and vertical surfaces. The radiator emits short-wave infrared rays. Lamp color – red (ruby).



> ADVANTAGES

- full control over the operating time and generated power
- pulse or constant operation mode
- significantly reduces the drying time of all types of spray-painting and lacquering products
- effectively heats only the repaired area
- temperature increment begins from the metal to the surface of the dried layer
- the infrared wave energy passes through air nearly without losses and immediately affects the repaired area

> TECHNICAL DATA

Voltage: 230V / 50Hz
 Max power consumption: 3300 W
 Power adjustment: from 35% to 100%
 Time adjustment: from 1 to 99 min.
 Dried surface area: 1200 x 1000 mm



APP NO.	Description
190281	3 x 1,1 kW radiator with timed off-switch and power adjustment on an extension arm





• NTools FDS 2000 Plus

2 x 1,1 kW radiator with timed off-switch, on an extension arm

The NTools FDS 2000 Plus infrared radiator features two lamps with a power of 1100 W each and an electronic, timed off-switch. The extension arm with a telescopic lock enables drying of corners, horizontal surfaces, such as roofs and engine and trunk covers. The radiator emits short-wave infrared rays. Lamp color - red (ruby).

> ADVANTAGES

- significantly reduces the drying time of all types of spray-painting and lacquering products
- effectively heats only the repaired area
- temperature increment begins from the metal to the surface of the dried layer
- the infrared wave energy passes through air nearly without losses and immediately affects the repaired area
- mirror reflectors, casings and radiators made from aluminum, efficiently dissipate heat from the radiators

> TECHNICAL DATA

Voltage: 230V / 50Hz

Power consumption: 2200 W

Time adjustment: from 1 to 99 min.

Dried surface area: 1000 x 800 mm



APP NO.	Description
190280P	2 x 1,1 kW radiator with timed off-switch, on an extension arm



• NTools FDS1000

1 x 1 kW radiator with electro-mechanical timed off-switch

The NTools FDS 1000 infrared radiator features a 1000 W lamp and an electromechanical timed off switch. It is designed for quick and small SPOT/SMART type repairs. The radiator emits short-wave infrared radiation. Lamp color- red (ruby).

> ADVANTAGES

- significantly reduces the drying time of all types of spray-painting and lacquering products
- effectively heats only the repaired area
- temperature increment begins from the metal to the surface of the dried layer
- the infrared wave energy passes through air nearly without losses and immediately affects the repaired area
- mirror reflectors, casings and radiators made from aluminum, efficiently dissipate heat from the radiators

> TECHNICAL DATA

Voltage: 230V / 50Hz

Power consumption: 1000 W

Time adjustment: from 1 to 60 min.

Dried surface area: 800 x 500 mm



APP NO.	Description
190279	1 x 1 kW radiator with electro-mechanical timed off-switch



• NTools FDS 1000/2000

Filament for infrared radiator

Quartz filament for the FDS 1000 infrared radiator.

> TECHNICAL DATA

Voltage: 230V / 50Hz Length: 41 cm
Power consumption: 1000 W Connection: cord plug
Color: ruby

APP NO.	Size
190293	41 cm



• NTools FDS 2000Plus/3300/6600

Filament for infrared radiator

Quartz filament for the FDS 2000 Plus, FDS 3300 and FDS 6600 infrared radiators.

> TECHNICAL DATA

Voltage: 230V / 50Hz Length: 53 cm
Power consumption: 1100 W Connection: cord plug
Color: ruby

APP NO.	Size
190296	53 cm



• NTools PP 1

NTools FDS 1000 radiator cover

The NTools PP covers are designed to protect the coffers and filaments of NTools FDS radiators against accumulation of dust and aerosols when the radiators are unused. The covers are made from slick, waterproof nylon (100% polyester) that is easy to keep clean. The covers feature a sewn in string with a stopper that allows them to be comfortably placed and fastened to the radiator coffers.

APP NO.	Compatible with	Size
190309	FDS 1000	49 x 21 x 28 cm



• NTools PP 2

NTools FDS 2000 Plus radiator cover

The NTools PP covers are designed to protect the coffers and filaments of NTools FDS Plus radiators against accumulation of dust and aerosols when the radiators are unused. The covers are made from slick, waterproof nylon (100% polyester) that is easy to keep clean. The covers feature a sewn in string with a stopper that allows them to be comfortably placed and fastened to the radiator coffers.

APP NO.	Compatible with	Size
190310	FDS 2000 Plus	59 x 64 x 43 cm



• NTools PP 3

NTools FDS 3300 and FDS 6600 radiator covers (2 pieces)

The NTools PP covers are designed to protect the coffers and filaments of NTools FDS radiators against accumulation of dust and aerosols when the radiators are unused. The covers are made from slick, waterproof nylon (100% polyester) that is easy to keep clean. The covers feature a sewn in string with a stopper that allows them to be comfortably placed and fastened to the radiator coffers.

APP NO.	Compatible with	Size
190311	FDS 3300	61 x 73 x 48 cm



SPRAY-PAINTING

1



Pneumatics

21-232 SPRAY-PAINTING

- 21-28 Putties and fillers
- 29-36 Base and primers
- 37-46 Top coats
- 47-56 Modular color selection system
- 57-62 Thinners, removers and additives
- 63-67 Repair of plastics
- 69-76 Adhesives and sealants
- 77-84 Car body protection and soundproofing
- 85-96 Abrasives
- 97-106 Masking systems
- 107-118 Polishing
- 119-126 OHS
- 127-132 Fabric filters and spray-painting booth accessories
- 133-154 Workshop auxiliary equipment
- 155-170 Various spray-painting products
- 171-178 Spray guns and extruders
- 179-186 Pneumatic grinders
- 187-192 Electric grinders, heat guns and lamps
- 193-198 Work disks
- 199-204 Dust extraction
- 205-208 Radiators
- 209-218 • Pneumatics**
- 219-222 Spray gun regenerators and washers
- 223-232 Technical sprays

• NTools PDP 3

Air blow gun with a long, straight nozzle

➤ Professional blowing gun with a straight nozzle:

- made from a plastic material (P.O.M), characterized by a high Hardness factor and low susceptibility to abrasion, which makes the gun more resistant to wear, it does not dissolve or expand in solvents, petrol and mineral oils,
- features a straight, steel nozzle with a length of 10 cm,
- it is designed for purging difficult to reach places with air, as well as for spot applications,
- equipped with an air connector (pin) compatible with all commonly used, standard quick connectors.

APP NO.	Description
388013	Air blow gun with a long, straight nozzle



• NTools PDP 4

Air blow gun with a Venturi nozzle

➤ Professional blowing gun with a Venturi nozzle:

- made from a plastic material (P.O.M), characterized by a high hardness factor and low susceptibility to abrasion, which makes the gun more resistant to wear
- designed for air blowing an element immediately prior to painting,
- by using a special nozzle, it ensures a significantly larger blown air surface,
- can be used for spot air blowing – requires detachment of the front Venturi nozzle,
- equipped with an air connector (pin) compatible with all commonly used, standard quick connectors.

APP NO.	Description
388015	Air blow gun with a Venturi nozzle



• NTools DP PEN

Air blow nozzle

The NTools DP PEN is an air blow nozzle with coaxial air flow adjustment. It enables quick and precise cleaning of surfaces as well as difficult to reach areas. The nozzle is made from aluminum, which makes it highly durable and light, with a shape resembling a pen.

➤ ADVANTAGES

- smooth air flow adjustment
- fastening clip
- knurled grip
- low weight of 25 g

APP NO.	Description
388016	Air blow nozzle



• NTools 25/B3

Rubber air blow tip

A handy and very convenient rubber air blow tip with a Rectus 26 / DN 7,2 type quick connector plug.

APP NO.	Description
388014	Rubber air blow tip
389258	NTools ZL 2, Quick connect plug EURO DN 7,2 with external thread G 1/4", brass



APP 388014



APP 389258

• APP MANO 3

Air regulator with manometer

A coaxial, glandular compressed air regulator with a mechanical analog manometer for adjusting the value of working pressure supplied to a spray-gun. The transparent cover of the manometer gauge face is made of glass.

► TECHNICAL DATA

APP NO.	389296
Description	APP MANO 3 Air regulator with manometer
Nominal manometer size	40 mm
Manometer measuring range	10 bar
Max. constant working pressure	7,5 bar
Accuracy class	1,6
Smooth pressure regulation depending on flow rate	YES
Manometer body	steel
Regulator body	aluminium
Seals	PTFE
Spray-gun connector features an internal, 1/4" F-BSP cylindrical thread	1/4" F-BSP
Quick connector plug connector features an external, 1/4" M-BSP cylindrical thread	P 1/4" M-BSP
Weight	135 g



- ! Do not submerge in solvent!
- ! Do not place in automated spray-gun washers!

• APP MANO 9

Air regulator with manometer

A coaxial, glandular compressed air regulator with a mechanical analog manometer for adjusting the value of working pressure supplied to a spray-gun. The transparent cover of the manometer gauge face is made of plastic.

► TECHNICAL DATA:

- nominal manometer size 40 mm
- manometer measuring range 12 bar
- max. constant working pressure 9 bar
- scale markers every 0,2 bar
- accuracy class 2,5
- smooth pressure regulation depending on flow rate - YES
- spray-gun connector features an internal, 1/4" F-BSP cylindrical thread
- quick connector plug connector features an external, 1/4" M-BSP cylindrical thread

- ! Do not submerge in solvent!
- ! Do not place in automated spray-gun washers!



APP NO.	Color / Option	Weight / Size	Sales units	Col. pack.
389299	-	1/4" thread	pcs.	pcs.

• NTools AH 15

Antistatic air hose 8 x 15 mm with connectors

The NTools AH 15 is a high quality antistatic hose made from two layers of rubber: black and red. The red outer layer is resistant to abrasion, dirt, and difficult exploitation conditions. The inner, reinforced black layer is resistant to mild oils and greases and is designed for transporting air.

Between the layers is a polyester braiding intended for reinforcement, and thin copper wires granting the hose its antistatic properties.

The hose is characterized by high elasticity and resistance to compression, stretching and bending. Does not contain silicone.

APP NO.	Color	Size
389034	red	15 m



• NTools AH 10

Antistatic air hose 8 x 15 mm with connectors

The NTools AH 10 is a high quality antistatic hose made from two layers of rubber: black and red. The red outer layer is resistant to abrasion, dirt, and difficult exploitation conditions. The inner, reinforced black layer is resistant to mild oils and greases and is designed for transporting air.

Between the layers is a polyester braiding intended for reinforcement, and thin copper wires granting the hose its antistatic properties.

The hose is characterized by high elasticity and resistance to compression, stretching and bending. Does not contain silicone.

APP NO.	Color	Size
389033	red	10 m



• NTools AH 50

Antistatic air hose 8 x 15 mm

The NTools AH 50 is a high quality antistatic hose made from two layers of rubber: black and red. The red outer layer is resistant to abrasion, dirt, and difficult exploitation conditions. The inner, reinforced black layer is resistant to mild oils and greases and is designed for transporting air.

Between the layers is a polyester braiding intended for reinforcement, and thin copper wires granting the hose its antistatic properties.

The hose is characterized by high elasticity and resistance to compression, stretching and bending. Does not contain silicone.

APP NO.	Color	Sales units
389040	red	mb



• NTools SZP 1

Quick connector socket with a nylon locking flange and G 1/4" external thread, nickel-plated brass

A one-way stop lock quick connector socket with ball locks, with a universal profile and an external, G 1/4" (ISO 228) cylindrical thread. Made from nickel-plated brass with a shock-resistant, nylon locking flange. One-handed operation.

Operating temperature: -15°C to +80°C.

Operating pressure: < 20 bar.

Compatibility: ATLAS COPCO QIC II; RECTUS 14, 22, 23, 24, 25, 26; ISO 6150 B; TEMA 1400, 1600; CEJN 300, 310, 320; PARKER 20, 30, 50 and other German, Italian, Swedish and American products.

APP NO.	Description	Size
389212	external thread	1/4"





• NTools SZP 2

Quick connector socket with a nylon locking flange and G 1/4" internal thread, nickel-plated brass

A one-way stop lock quick connector socket with ball locks, with a universal profile and an internal, G 1/4" (ISO 228) cylindrical thread. Made from nickel-plated brass with a shock-resistant, nylon locking flange. One-handed operation.

Operating temperature: -15°C to +80°C.

Operating pressure: < 20 bar.

Compatibility: ATLAS COPCO QIC II; RECTUS 14, 22, 23, 24, 25, 26; ISO 6150 B; TEMA 1400, 1600; CEJN 300, 310, 320; PARKER 20, 30, 50 and other German, Italian, Swedish and American products.



APP NO.	Description	Size
389208	internal thread	1/4"

• NTools SZP 3

Quick connector socket with a nylon locking flange and G 1/2" external thread, nickel-plated brass

A one-way stop lock quick connector socket with ball locks, with a universal profile and an external, G 1/2" (ISO 228) cylindrical thread. Made from nickel-plated brass with a shock-resistant, nylon locking flange. One-handed operation.

Operating temperature: -15°C to +80°C.

Operating pressure: < 20 bar.

Compatibility: ATLAS COPCO QIC II; RECTUS 14, 22, 23, 24, 25, 26; ISO 6150 B; TEMA 1400, 1600; CEJN 300, 310, 320; PARKER 20, 30, 50 and other German, Italian, Swedish and American products.



APP NO.	Description	Size
389214	external thread	1/2"

• NTools SZP 4

Quick connector socket with a nylon locking flange and an 8 mm hose sleeve, nickel-plated brass

A one-way stop lock quick connector socket with ball locks, with a universal profile and 8 mm hose sleeve. Made from nickel-plated brass with a shock-resistant, nylon locking flange. One-handed operation.

Operating temperature: -15°C to +80°C.

Operating pressure: < 20 bar.

Compatibility: ATLAS COPCO QIC II; RECTUS 14, 22, 23, 24, 25, 26; ISO 6150 B; TEMA 1400, 1600; CEJN 300, 310, 320; PARKER 20, 30, 50 and other German, Italian, Swedish and American products.



APP NO.	Size	Col. pack.
389204	8 mm	pcs.

• NTools SZP 5

Self-depressurizing quick connector socket for safe disconnection and 9 mm hose sleeve

A one-way stop lock self-depressurizing quick connector socket with ball locks, for safe disconnection, with a 9 mm hose sleeve. Protects against impact of the hose end with a plug when in a state of abrupt and uncontrolled depressurization. Made from a durable composite, wear-resistant metal elements and NBR seals. One-handed operation.

Operating temperature: -15°C to +70°C.

Operating pressure: < 12 bar.

Compatibility: commercially available DN 7,2 mm pins.



APP NO.	Size
389031	9 mm



• NTools SZP 6

Quick connector socket EURO DN 7,2
with an 8 mm hose sleeve, brass

A one-way stop lock quick connector socket with a standard EURO DN 7,2 profile and an 8 mm hose sleeve. Made from brass, with an ergonomic locking sleeve protecting the valve against dirt. The spring and locks are made from stainless steel, and seals from NBR. One-handed operation.

Operating temperature: -20°C to +100°C.

Operating pressure: < 35 bar.

Compatibility: RECTUS 26, RECTUS 25, RECTUS 1600/1625
TEMA 1600, CEJN 320, JWL 520 + JWL 530
and other German products.

APP NO.	Size
389201	8 mm



• NTools ZL 1

Quick connector plug EURO DN 7,2
with a G 1/4" internal thread, brass

A quick connector plug with a standard EURO DN 7,2 profile and a cylindrical G 1/4" internal thread. Made from brass. Designed for spray-guns.

Compatibility: RECTUS 26, RECTUS 25, RECTUS 1600/1625
TEMA 1600, CEJN 320, JWL 520 + JWL 530
and other German products.

APP NO.	Description	Size
389257	internal thread / brass	1/4"



• NTools ZL 2

Quick connector plug EURO DN 7,2
with a G 1/4" external thread, brass

A quick connector plug with a standard EURO DN 7,2 profile and a cylindrical G 1/4" external thread. Made from brass. Designed for pneumatic grinders.

Compatibility: RECTUS 26, RECTUS 25, RECTUS 1600/1625
TEMA 1600, CEJN 320, JWL 520 + JWL 530
and other German products.

APP NO.	Description	Size
389258	external thread	1/4"



• NTools ZL 6

Quick connector nozzle EURO DN 7,2 for hose

A quick connector plug with a standard EURO DN 7,2 profile with an 8 mm hose sleeve. Made from electrogalvanized brass. Designed for hoses made from PVC, EPDM, etc.

Compatibility: RECTUS 26, RECTUS 25, RECTUS 1600/1625
TEMA 1600, CEJN 320, JWL 520 + JWL 530
and other German products.

APP NO.	Size
389254	8 mm



• NTools ZL 7

Quick connector plug EURO DN 7,2 with 8 mm hose sleeve, brass

A quick connector plug with a standard EURO DN 7,2 profile with an 8 mm hose sleeve. Made from brass. Designed for hoses made from PVC, EPDM, etc.

Compatibility: RECTUS 26, RECTUS 25, RECTUS 1600/1625 TEMA 1600, CEJN 320, JWL 520 + JWL 530 and other German products.

APP NO.	Size
389255	8 mm



• NTools ZL 3

8 mm hose connection sleeve

A two-sided hose sleeve with a diameter of 8 mm made from nickel-plated brass. Designed for joining hoses made from, e.g. PVC, EPDM, etc.

APP NO.	Size
389282	8 mm



• APP E32 A

Cabin filtration block with regulator, manometer, and oil separator

The cabin filtration block consists of an E34 filter-reducer system and an E38D oil separator. The filter-reducer system is used to remove solid and liquid contaminants and to set and maintain a constant pressure, while the oil separator is designed to remove the water-oil film residues. Following the filtration block, the air quality is compliant with the ISO 8573-1 standard.

APP NO.	381050
Description	Cabin filtration block with regulator, manometer, and oil separator
Nominal air flow for 6 bar:	2400 l/min (144 m³/h)
Purification accuracy:	0,01 µm / 0,1 mg/m³
Operating pressure:	1,5 bar to 12 bar
Operating temperature:	+1,5°C to +65°C
Connector thread:	1/2" BSP
Max. operating pressure:	12 bar
Weight	2,170 kg



• APP E34

Cabin air filter with regulator and manometer

The filter-reducer system is designed to remove solid and liquid contaminants from compressed air and to set and maintain a constant pressure in pneumatic supply systems, regardless of pressure changes in the network above the supply pressure. It features an automatic condensate discharge.

APP NO.	381010
Description	Cabin air filter with regulator and manometer
Nominal air flow for 6 bar:	2450 l/min (147 m³/h)
Purification accuracy:	10 µm
Operating pressure:	1,5 bar to 12 bar
Operating temperature:	-25°C to +65°C
Connector thread:	1/2" BSP
Max. operating pressure:	12 bar
Weight	1,180 kg



• APP E38 D

Precise cabin air filter – oil separator

The oil separator – micro-filter is designed to remove water and oil residue to a maximum residual content of 0,1 mg/m³, and solid particles no larger than 0,01 µm. Following the filter, the air quality is compliant with the ISO 8573-1 standard: particle dimensions – class 1 and max. oil content – class 1. Replacement of the coalescing filtration cartridge according to the indications of the differential gauge or every 8600 h of work. Features a manual condensate discharge.

APP NO.	381020
Description	Precise cabin air filter – oil separator
Nominal air flow for 6 bar:	2400 l/min (144 m ³ /h)
Purification accuracy:	0,01 µm / 0,1 mg/m ³
Operating pressure:	1,5 bar to 12 bar
Operating temperature:	+1,5°C to +65°C
Connector thread:	1/2" BSP
Max. operating pressure:	12 bar
Weight	0,825 kg



• APP UMF 1

Steel filter mounting bracket

Mounting bracket for cabin filters.

APP NO.	Description
382815	Steel filter mounting bracket



• APP UMF 2

Connector mounting bracket

Mounting bracket for cabin filters.

APP NO.	Description
382810	Connector mounting bracket



• APP UMF 1

Block connector

Mounting bracket for cabin filters.

APP NO.	Description
382805	Block connector



• APP UMF 4

3 x 1/2 distributor

Mounting bracket for cabin filters.

APP NO.	Description
382820	3 x 1/2 distributor



• APP B1S+

Air preparation block (filter + oiler) for pneumatic machines

Basic filtering-oiling set for use with pneumatic machines. Comprised of a filter with a manometer (382010) and an oiling unit (382030).

APP NO.	Description
382050	Air preparation block (filter + oiler) for pneumatic machines



• APP FRS+

Air filter with regulator and manometer for pneumatic machines

An air purification filter with a manometer designed for use as the final stage of filtration in compressed air installations. Removes contaminants such as solid particles and condensed, oily water from the installation.

APP NO.	Description
382010	Air filter with regulator and manometer for pneumatic machines



• APP NS+

Air oiler for pneumatic machines

An oiler for dispersing an appropriate amount of oil in the passing air, in order to ensure lubrication for the operating pneumatic machines and equipment.

APP NO.	Description
382030	Air oiler for pneumatic machines



• APP RS+

Pressure regulator with manometer for pneumatic machines

Pressure regulator with a manometer for assembly on pneumatic installations.

APP NO.	Description
382040	Pressure regulator with manometer for pneumatic machines



• APP B2S

Air block with oiler, manometer, regulator and distributor for pneumatic machines

Basic filtering-oiling set for use with pneumatic machines and equipment. It consists of a filter with a manometer (382010) and an oiler (382030), as well as a distributor to spray-painting equipment, e.g. a spray-gun.

APP NO.	Description
382055	Air block with oiler, manometer, regulator and distributor for pneumatic machines



SPRAY-PAINTING

1



Spray gun regenerators
and washers

21-232 SPRAY-PAINTING

- 21-28 Putties and fillers
- 29-36 Base and primers
- 37-46 Top coats
- 47-56 Modular color selection system
- 57-62 Thinners, removers and additives
- 63-67 Repair of plastics
- 69-76 Adhesives and sealants
- 77-84 Car body protection and soundproofing
- 85-96 Abrasives
- 97-106 Masking systems
- 107-118 Polishing
- 119-126 OHS
- 127-132 Fabric filters and spray-painting booth accessories
- 133-154 Workshop auxiliary equipment
- 155-170 Various spray-painting products
- 171-178 Spray guns and extruders
- 179-186 Pneumatic grinders
- 187-192 Electric grinders, heat guns and lamps
- 193-198 Work disks
- 199-204 Dust extraction
- 205-208 Radiators
- 209-218 Pneumatics
- 219-222 • Spray-gun regenerators and washers**
- 223-232 Technical sprays

• IST C1 i IST C2

Regenerators with 10 and 15 liter tanks

The IST company has developed the series C distillers with medium and larger car repair workshops in mind. The C series distillers are characterized by high reliability due to their structure and use of high quality materials in the construction of individual elements. The tanks is made from AISI 304 stainless steel, which makes it resistant to the effects of organic solvents. The cooling system is made from copper tubes which guarantee the system's longevity. The process of separating dilutable pigments and other solid elements involves evaporation from the mixture created from washing spray-guns and other devices. After heating to a sufficient temperature, the solvent begins to evaporate and is then cooled in an air-cooled condenser. After an appropriate time has passed, the regenerator deactivates automatically. The device's construction allows easy removal of distillation residues from the tank. The use of special bags allows easier and quicker removal of tank contents while maintaining the device's cleanliness.



APP 200100



APP 200110



► TECHNICAL DATA

APP NO.	APP 200100	APP 200110
Description	IST C1	IST C2
Reservoir capacity	10 L	15 L
Supply voltage	230 V / 50-60 Hz	230 V / 50-60 Hz
Rated power	W 1600	W 1600
Operating temperature:	50-190°C	50-190°C
Indirect heating by diathermy oil	ESSOTERM 500	ESSOTERM 500
Amount of diathermy oil	6 L	7,5 L
Cooling	ventilation with forced air circulation	
Electrical system standard	EN 60204-1	

• NTS WPD

Polyamide bag

Consumable accessories for distillers.

APP NO.	Description	Size	Sales units	Col. pack.
200109	10 L	350 x 470 mm	pack. 10 pcs.	-
200119	15 L	430 x 550 mm	pack. 10 pcs.	220 pcs.
200149	20-25 L	540 x 650 mm	pack. 10 pcs.	150 pcs.
200169	60 L	660 x 850 mm	pack. 10 pcs.	-



• IST OIL D

Regenerator oil

Diathermic oil for IST distillers. Oil applications: mineral based heat carrier in regenerators, including IST C1 (APP No. 200100) and IST C2 (APP No. 200110), use in household and industrial heating, air conditioning, air compressors, heating systems with heat exchangers, all other systems (pipelines, pumps, etc.), heating of heat baths, autoclaves, reactors, furnaces, casting molds, drying tunnels, injectors, etc., production processes (cement, paper, industry, timber, etc.).

APP NO.	Volume
200300	1L



• Uniram UG 110

Washer for one spray-gun for water-dilutable or conventional paints and lacquers

The UG110 automated washer allows to quickly wash one spray-gun or one 600 ml capacity cup. The washing cycle takes only 60 seconds thanks to the incorporation of 6 nozzles and a very efficient diaphragm pump. The washer is equipped with a mechanical clock controlling the washing process. All elements that come in contact with the cleaning compound are made from materials resistant to water.

APP NO.	Description
200010	automatic

! Single station device / automatic



• Uniram UM 120

Washer for one spray-gun
for water-dilutable paints and lacquers

A manual washer for cleaning a spray-gun used for applying water-dilutable lacquers. It is equipped with a movable nozzle and a cleaning brush. The system of automatic coagulation with air mixing and filtering guarantees precipitation of paint and lacquer residue from the solvent. All elements that come in contact with solvent are made from stainless steel. *The washer is delivered with solvent containers.

APP NO.	Description
200012	single-circuit / manual



• Uniram UG 4000DVM

Washer for two spray-guns with extraction
for water-dilutable or conventional lacquers

The automated washer allows to wash 2 spray guns and 2 standard 600 ml capacity cups used for painting with organic solvent-based lacquers. The washing cycle lasts only 60 seconds thanks to 14 cleaning nozzles and a very efficient diaphragm pump. The UG 4000 features a clock that controls the washing process, a blowing and clean solvent rinsing phase button. All elements in contact with solvent are made from stainless steel. The washer also allows manual washing using a brush. After pressing the pedal, solvent is delivered directly to the brush.

* The washer is delivered without the solvent canisters.

APP NO.	Description
200040	two-circuit / automatic



• Uniram UG 5000 W

Washer for two spray-guns with extraction
for water-dilutable or conventional lacquers

A washer for products based on organic and water-dilutable solvents. A combination of the UG 4000 and UM 120 W washers. The automated washer allows to clean 2 spray-guns and 2 standard 600 ml capacity cups used for painting with organic solvent-based paints and lacquers. The washing cycle lasts only 60 seconds thanks to 14 cleaning nozzles and a very efficient diaphragm pump. The washer features a clock that controls the washing process, a blowing and clean solvent rinsing phase button. All elements in contact with solvent are made from stainless steel. The washer also allows manual washing using a brush. After pressing the pedal, solvent is delivered directly to the brush. The manual washer allows to clean a spray-gun used for applying water-dilutable lacquers. It features a movable nozzle and cleaning brush. The system of automatic coagulation with air mixing and filtering guarantees precipitation of paint and lacquer residue from the solvent. All elements in contact with solvent are made from stainless steel.

APP NO.	Description
200050	two-circuit / automatic



SPRAY-PAINTING

1



Technical sprays

21-232 SPRAY-PAINTING

- 21-28 Putties and fillers
- 29-36 Base and primers
- 37-46 Top coats
- 47-56 Modular color selection system
- 57-62 Thinners, removers and additives
- 63-67 Repair of plastics
- 69-76 Adhesives and sealants
- 77-84 Car body protection and soundproofing
- 85-96 Abrasives
- 97-106 Masking systems
- 107-118 Polishing
- 119-126 OHS
- 127-132 Fabric filters and spray-painting booth accessories
- 133-154 Workshop auxiliary equipment
- 155-170 Various spray-painting products
- 171-178 Spray guns and extruders
- 179-186 Pneumatic grinders
- 187-192 Electric grinders, heat guns and lamps
- 193-198 Work disks
- 199-204 Dust extraction
- 205-208 Radiators
- 209-218 Pneumatics
- 219-222 Spray gun regenerators and washers
- 223-232 • Technical sprays**

- **APP BR 01 Spray**
Brake system cleaner

APP BR 01 Spray is an active cleaning compound with a strong de-greasing effect, designed for brakes, clutches and oil covered machine and equipment parts. It allows to clean disk brakes, drum brakes (brake pad deposits), as well as clutch plates and linings of undesired layers of oil and grease.

➤ **ADVANTAGES**

- does not contain acetone, chlorine and etching substances
- very strong de-greaser
- quick evaporation
- broad application range

APP NO.	Weight / Size	Col. pack.
212005	600 ml	12 pcs.



- **APP BR 01**
Brake system cleaner

APP BR01 is a quick-evaporating, active cleaning product with a strong de-greasing effect designed for brakes, clutches, and oil-covered machine parts. It does not cause corrosion and leaves no deposits. It does not contain acetone, chlorine and etching substances. It is neutral to rubber, plastic materials and lacquered surfaces.

➤ **ADVANTAGES**

- neutral to seals and covers from rubber and plastic
- removes seared and clvinging greases
- de-greases and leaves no contamination
- quickly evaporates ensuring an optimal cleaning effect

APP NO.	Weight / Size
030705	5 L



- **APP ZU 500 Spray**
Multi-purpose universal cleaner

APP ZU 500 Spray is a multi-functional universal cleaner with a strong de-greasing effect. It dissolves and removes oils, grease, resin, glues and deposits from clutch linings and brakes

➤ **ADVANTAGES**

- cleans and degreases heavily dirt covered surfaces – contains acetone
- cleans difficult to remove stains from upholstery and fabrics
- leaves cleans surfaces glossy
- suitable for cleaning electrical installations and starter motors
- broad application range

APP NO.	Weight / Size	Col. pack.
211090	600 ml	12 pcs.



• APP WB 30 Spray

Rust remover with molybdenum disulfide MoS₂

APP WB 30 Spray is a compound with rust removing and lubricating properties containing molybdenum disulfide MoS₂. It allows to quickly disassemble corroded and seared connections. The product eliminates grating and creaking by lubricating sliding surfaces. It cleans and preserves brake systems, elastic connecting lines, and all types of chains. Does not contain silicone.

> ADVANTAGES

- dissolves rust and loosens all seared connections
- provides lasting corrosion protection
- lubricates sliding surfaces
- provides surfaces subject to friction processes with particular protection of elements against wear in both low and high temperatures

APP NO.	Weight / Size	Col. pack.
212010	400 ml	12 pcs.



• APP SIL 120 Spray

Silikon

APP SIL 120 Spray is a sliding, insulating, protective and care product for plastics, wood, rubber, and metal. It does not contain fats or solvents. The product forms a clean and non-hardening sliding layer with antistatic properties. It protects elements against moisture and oxidation with a thin layer and provides good electrical insulation.

> ADVANTAGES

- eliminates onerous squeaks and grating that accompany friction
- extends the service life and elasticity of seals and other rubber elements
- protects plastic materials against aging – gives them gloss
- protects against water and corrosion
- temperature resistance from -30°C to +120°C

APP NO.	Weight / Size	Col. pack.
212007	400 ml	12 pcs.



• APP BS 80 Spray

White lubricant

APP BS 80 Spray is a universal lubricating agent containing PTFE with a neutral pH. It is designed for use under heavy loads and in high temperatures. The product is resistant to acids, salts and bases in low concentrations.

> ADVANTAGES

- displaces water, protects metal against corrosion and oxidation
- eliminates onerous squeaks and grating that accompany friction
- protects moving elements against blockage
- secures moving metal elements against freezing
- temperature resistance from -30°C to +180°C

APP NO.	Weight / Size	Col. pack.
212008	400 ml	12 pcs.



• APP SM 1100 Spray

Copper lubricant

APP SM 1100 Spray is a lubricating compound with a high copper content. It prevents jamming of metal element connections exposed to high temperatures. It is designed for use in threaded connections and contact points of metal elements.

➤ ADVANTAGES

- anti-corrosion effect
- facilitates unscrewing of bolts and nuts seared due to extended periods of exploitation and high temperatures
- resistant to the effects of many chemical substances and atmospheric effects
- improves the tightness of threaded connections, especially those exposed to frost and sunlight
- temperature resistance from -40°C to $+1100^{\circ}\text{C}$

APP NO.	Weight / Size	Col. pack.
212009	400 ml	12 pcs.



• APP W 11 Spray

Vaseline

APP W 11 Spray is a technical Vaseline aerosol spray. It is a high quality, transparent preserving and anti-corrosion lubricant with a neutral pH value. It protects against sticking and bonding of lubricated elements. It is designed for securing battery poles, locks, bolts, electrical connections, etc.

➤ ADVANTAGES

- displaces water, protects against corrosion and oxidation
- characterized by excellent adhesion
- eliminates onerous squeaks and grating that accompany friction between elements working together
- resistant to the effects of weak acids and bases, and adverse weather conditions
- temperature resistance from -30°C to $+160^{\circ}\text{C}$

APP NO.	Weight / Size	Sales units
212031	400 ml	12 pcs.



• APP SC 1200 Spray

Ceramic lubricant

APP SC 1200 Spray is a high temperature-resistant, ceramic lubricating compound for use on elements under heavy thermal and mechanical stress. It is designed for use in brake systems, anti-lock brakes, installation of brake pads, installation of exhaust systems and LAMBDA probes, and connections exposed to high temperatures.

➤ ADVANTAGES

- facilitates disassembly of previously lubricated elements
- prevents corrosion and sticking of lubricated elements
- has the consistency of a paste, contains ceramic particles
- eliminates onerous squeaks and grating that accompany friction
- resistant to chemicals (water, salts, weak acids and bases) and adverse atmospheric conditions
- temperature resistance from -40°C to $+1200^{\circ}\text{C}$

APP NO.	Weight / Size	Col. pack.
212032	400 ml	12 pcs.



• APP ST 250 Spray

PTFE lubricant

APP ST 250 Spray is a high quality lubricating compound with PTFE for use on metal, plastic and rubber elements subject to heavy mechanical loads. It significantly extends the exploitation time of moving parts.

➤ ADVANTAGES

- features a very low friction coefficient
- has penetrating capabilities
- protects against corrosion and oxidation
- prevents sticking of lubricated elements
- temperature resistance from -50°C to +250°C

APP NO.	Weight / Size	Col. pack.
212033	400 ml	12 pcs.



• APP SL 280 Spray

Chain lubricant

APP SL 280 Spray is a synthetic lubricating element for lasting maintenance of chains, lines, bearings and geared transmissions. The product limits adhesion of dust and sand particles to the lubricated elements.

➤ ADVANTAGES

- very good protection against corrosion
- limits mechanical wear
- displaces moisture and preserves surfaces
- does not drip or spread spontaneously,
- does not stain neighboring parts
- temperature resistance from -40°C to +150°C

APP NO.	Weight / Size	Col. pack.
212030	400 ml	12 pcs.



• APP WN 360 Spray

Pressure installation leakage detection compound

APP WN 360 Spray is a compound for quick and precise location of leaks in pressure installations containing liquids or gas. It is intended for all types of pressure installations.

➤ ADVANTAGES

- noncombustible, non-toxic, environmentally friendly, not harmful to skin
- does not cause corrosion, can be used on surfaces made of metal and plastic materials
- features a 360° valve that enables proper operation in any position
- additional 15 cm tube enabling product application onto difficult to reach areas
- does not require washing after use

APP NO.	Weight / Size	Col. pack.
212004	400 ml	12 pcs.



view video 



• APP SPAW Spray

Welding nozzle cleaning and maintenance compound

APP SPAW Spray is a highly effective and efficient compound that provides comprehensive protection during welding. It extends the service life of gas and contact nozzles. The product cleans and maintains welding torch nozzles. It protects torch heads and welded elements against spatter without weakening the welded seam

➤ ADVANTAGES

- protects the torches, grips and welded elements against spatter, extending their service life and technical efficiency
- facilitates removal of flammable spatter and contamination created on the surfaces of tools and torch nozzles during welding
- enables quick cleaning and replacement of nozzles
- does not contain silicone



APP NO.	Weight / Size	Col. pack.
212013	400 ml	12 pcs.

• APP CD Drill Spray

Cutting and drilling support compound

APP CD Drill Spray is a compound facilitating cutting and drilling. It is a high quality mineral oil that prevents overheating of metals and improves processing parameters. It is recommended for difficult to process materials such as stainless steel, aluminum, colored metals, precious metals, brass, and other metal alloys.

➤ ADVANTAGES

- features very good anti-corrosion and penetrating properties
- protects, secures and decreases the wear of tools
- facilitates cutting, sawing, threading, bolting, turning, milling and drilling
- speeds up the machine cutting process
- does not contain silicone



APP NO.	Weight / Size	Col. pack.
212065	400 ml	12 pcs.

• APP KS E Spray

Compound for preserving and displacing moisture from electrical systems

APP KS E Spray is an anti-moisture and anti-corrosion compound that increases the reliability of electrical installations. It removes oxidized areas on contacts by displacing water. The product eliminates and prevents the occurrence of interruptions and failures in electrical installations caused by moisture.

➤ ADVANTAGES

- protects against moisture and displaces water
- removes oxidized spots on contacts and provides long-term corrosion protection
- prevents voltage losses and leakage currents
- ensures uninterrupted electric current flow



APP NO.	Weight / Size	Col. pack.
212059	400 ml	12 pcs.

• APP Zink 98 Spray

Zinc-based compound for professional corrosion protection

APP Zink 98 Spray is a quick-drying, zinc-based compound that forms a smooth and non-porous protective coating. It ensures double, long-lasting corrosion protection: for metals, providing cathodic protection against corrosion, while simultaneously creating a protective, highly resistant synthetic resin coating. Color: dark grey.

➤ ADVANTAGES

- contains over 90% zinc and its compounds
- temperature resistance up to 300°C
- universal application
- ease of use

APP NO.	Color	Weight / Size	Col. pack.
210441	dark grey	400 ml	12 pcs.



• APP Zink Alu 19 Spray

Zinc and aluminum-based compound for professional corrosion protection

APP Zink Alu 19 Spray is a one-component, quick-drying mixture of aluminum and zinc for repair and corrosion protection of metal parts in industry and crafts. It features very high adhesion to iron, steel, zinc-coated steel, aluminum and colored metals. It creates a quick-drying and highly adhesive protective layer.

➤ ADVANTAGES

- temperature resistance up to 250°C, short term – up to 500°C
- after drying contains 67% zinc and 19% aluminum
- universal application
- ease of use

APP NO.	Color	Weight / Size	Col. pack.
210442	silver	400 ml	12 pcs.



• APP L 650°C Black Spray

Heatproof paint

APP L 650°C Black Spray is a special purpose paint spray based on silicone resin for use on steel and aluminum elements exposed to high temperatures. It is designed for painting engine blocks, radiator conduits, as well as grills, ovens, chimney ducts, etc. Does not crack or peel. After heating in a temperature of 220°C for 1 h, the coating is resistant to water, petrol and scratching.

➤ ADVANTAGES

- temperature resistance after curing 650°C
- excellent adhesion to the surface without any bases
- very good coverage and filling

APP NO.	Color	Weight / Size	Col. pack.
210431	black	400 ml	6 pcs.



• APP L 800°C Silver Spray

Heatproof paint

APP L 800°C Silver Spray is a special purpose paint spray based on silicone resin for use on steel and aluminum elements exposed to high temperatures. It is designed for painting engine blocks, radiator conduits, as well as grills, ovens, chimney ducts, etc. Does not crack or peel. After heating in a temperature of 220°C for 1 h, the coating is resistant to water, petrol and scratching.

➤ ADVANTAGES

- temperature resistance after curing 800°C
- excellent adhesion to the surface without any bases
- very good coverage and filling



APP NO.	Color	Weight / Size	Col. pack.
210433	silver	400 ml	6 pcs.

• APP SP 69 Spray

Compressed gas + freezer

APP SP 69 Spray is a pressurized canister containing compressed air and an accelerant gas. It is a 2in1 product – it cleans or freezes. When holding the canister with the valve upwards, the contents will be blown under high pressure, allowing to remove dust and other contaminants. When holding the canister in a reversed position (valve downward), the SP 69 contents allow to reduce the temperature of elements during their assembly or disassembly to -69°C.

➤ ADVANTAGES

- cleans and freezes
- additional 15 cm tube allows application of the compound in difficult to reach areas
- allows to reduce the temperature of elements during assembly or disassembly to -69°C
- wide scope of applications



APP NO.	Weight / Size	Col. pack.
212069	600 ml	12 pcs.

view video 



• APP PC 25 Spray

Multi-purpose foam for vehicle interior cleaning

APP PC 25 Spray is a universal foam characterized by high cleaning effectiveness. It quickly removes all difficult stains from grease, oil and tar. It can be used for cleaning glass, chrome-plated and plastic elements.

➤ ADVANTAGES

- excellent at removing insects from windshields and bodywork, as well as stains from carpets and upholstery
- does not leave foam marks in the cleaned spots
- gives a fresh appearance to matted, weathered plastics
- universal product with versatile application, for cleaning vehicle interiors, sports equipment, and for general household use



APP NO.	Weight / Size	Col. pack.
212016	400 ml	12 pcs.

• APP PS 50 Spray

Glass washing and cleaning foam

APP PS 50 Spray is a professional foam for washing and cleaning glass with an exceptionally effective formula that works quickly and efficiently. The foam is designed for cleaning glass surfaces, i.e. windows, fireplace glass, oven glass fronts, car windshields, mirrors, and headlights.

➤ ADVANTAGES

- excellent performance in cleaning road dirt or nicotine deposits
- thanks to the content of ammonia, it perfectly removes the most difficult oil, tar and grease stains
- the foam's formula ensures extended adhesion to the surface, enhancing its cleaning properties
- does not leave marks and streaks in the cleaning location
- guarantees clean glass and improved visibility

APP NO.	Weight / Size	Col. pack.
212017	400 ml	12 pcs.



• APP K 44 Spray

Air conditioner cleaning compound

APP K 44 Spray is an easy to use compound designed for cleaning and maintaining air conditioning and ventilation systems that is safe for the user. Thanks to a long and elastic tube, it enables use of the compound directly in the evaporator and other difficult to reach areas. Ensures a long-term effect.

➤ ADVANTAGES

- cleans, protects and extends the service life of the air conditioning system
- simple and easy to use – does not require costly and time-consuming disassembly of air conditioning system elements
- prevents issues with the respiratory tract and allergies
- safe for the user

APP NO.	Weight / Size	Col. pack.
212018	400 ml	12 pcs.



• APP Cockpit Spray

Silicone free vehicle interior care compound

APP Cockpit Spray is a scented compound for cleaning and maintaining vehicle cabins. It is intended for work on surfaces made of plastics, rubber, varnished wood and leather, e.g. dashboards, vinyl ceiling lining, rubber floor coverings, etc.

➤ ADVANTAGES

- extends the longevity of plastics, protects against staining, static charges, moisture and UV rays
- prevents dust deposits
- restores colors, leaves a pleasant, orange scent
- gives a lasting, easy to maintain and delicate matt finish
- does not contain silicone

APP NO.	Weight / Size	Col. pack.
212019	400 ml	12 pcs.



AUTO-CARE



Washing and cleaning
preparations

233- 264 AUTO-CARE

- 233 - 238** • **Washing and cleaning preparations**
- 239 - 242 Care and protection preparations
- 243 - 250 Sponges and brushes
- 251- 254 Microfiber cloths
- 255 - 260 Accessories - sprayers, applicators and dosing caps
- 261 - 264 Washing and cleaning devices

• APP MULTI Cleaner

Low-foam cleaning product

APP MULTI Cleaner - A concentrated preparation for cleaning car bodywork, engines, chassis, wheel rims, tarpaulin, workshop floors, plastic, rubber and glass elements. It removes oil and grease, soot, brake pad dust, non-organic and organic contamination and persistent stains.

APP NO.	Packaging	Content
220121	bottle	1,0 L
220122	canister	5,0 L
220123	canister	25,0 L

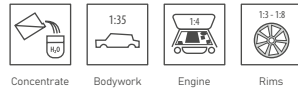

• APP M Multi Cleaner

Multi-purpose vehicle cleaning compound

APP M MULTI Cleaner - A concentrated preparation intended for cleaning motor vehicles. It effectively removes road dirt from car bodies, tarpaulins, and delivery vehicle bodies. It does not leave white stains on rubber and plastic elements. The product cleans and degreases the engine and all mechanical parts. It is highly alkaline. The compound does not contain solvents.

APP NO.	Packaging	Volume
220011	bottle	1,0 L
220012	canister	5,0 L
220013	canister	20,0 L

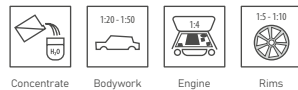

• APP M Active Foam

Compound for cleaning mechanical vehicle bodywork

APP M Active Foam - A concentrated active foam intended for contactless or manual washing of passenger and delivery vehicles, busses, and motorbikes. Thanks to a mixture of surfactants, it performs excellently against typical dirt. It can be used in different concentrations, allowing for frequent bodywork washing. The product is characterized by very high effectiveness.

APP NO.	Packaging	Volume
220021	bottle	1,0 L
220022	canister	5,0 L
220023	canister	10,0 L

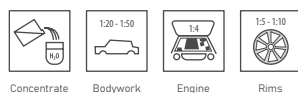

• APP UNI Cleaner

High-foam vehicle cleaning preparation

APP UNI Cleaner - A concentrated, universal washing shampoo. It dissolves and removes dirt from lacquered surfaces, glass, plastics, fabrics, rubber and chrome. The compound is intended for manual car washing, as well as for use in automatic car washes.

APP NO.	Packaging	Volume
220103	bottle	1,0 L
220105	canister	5,0 L



• APP M UNI Cleaner

High-foam vehicle cleaning preparation

APP M UNI Cleaner - A highly efficient preparation for washing motor vehicle bodies. It effectively removes dirt from lacquer coats, leaving a glossy surface. It dissolves and removes dirt from glass, plastic and rubber elements. The compound is designed for manual washing of passenger, all-terrain, and delivery vehicles.

APP NO.	Packaging	Content
220031	bottle	1,0 L
220032	canister	5,0 L
220033	canister	10,0 L

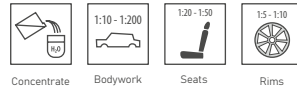

• APP M Nano Hydro Wax

Car bodywork drying and glossing preparation

APP M Nano Hydro Wax - A highly effective and efficient preparation for drying and glossing vehicle bodywork. The modern formula based on polymer nanoparticles speeds up car bodywork drying after washing, restores its natural gloss and, when used frequently, protects the paint against adverse atmospheric conditions. The compound can be used on all lacquered surface types. It does not leave discolorations on plastic and rubber elements. The product can be used on wet as well as previously dried lacquer. It is ready to use out of the container.

APP NO.	Packaging	Volume
220071	bottle	1,0 L
220072	canister	5,0 L



• APP INNER Cleaner

Interior washing and cleaning preparation

APP INNER Cleaner - A concentrated, highly efficient cleaning preparation for vehicle interior elements: fabric, velour and leather upholstery, coverings and floor mats, dashboards, and all interior plastic elements. It effectively removes all organic contamination and dirt.

APP NO.	Packaging	Volume
220106	bottle	1,0 L
220107	canister	10,0 L

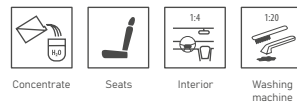

• APP M INNER Cleaner

Interior washing and cleaning preparation

APP M INNER Cleaner - A ready to use preparation for washing and cleaning vehicle interiors. It effectively removes dirt and stains from fabric and velour upholstery, restoring it to its original appearance.

APP NO.	Packaging	Volume
220084	bottle with sprayer	650 ml



• APP PC 25 Spray

Multi-purpose vehicle interior cleaning foam

APP PC 25 Spray is a universal foam characterized by high cleaning effectiveness. It quickly removes all persistent stains from grease, oil and tar. The product can also be used to clean glass, chrome-plated and plastic elements.

➤ ADVANTAGES

- effectively eliminates insects from windshields and bodywork, as well as stains and dirt from floor mats and upholstery
- does not leave marks in place of the removed stain
- restores the appearance of matted and weathered plastic materials
- universal product with versatile applications, for cleaning the interiors of motor vehicles, sports equipment, and for general household use

APP NO.	Volume	Sales units
212016	400 ml	pcs.



• APP FE Cleaner Extra

Acid-based car wheel rim cleaning compound

APP FE Cleaner Extra - An aggressive compound for cleaning extremely heavily soiled car wheel rims, containing a mixture of acids: phosphoric and hydrofluoric. Intended for use only by professionals. Applications: wheel rims made from steel and light alloys, excluding polished aluminum rims, non-lacquered and chrome plated aluminum rims.

APP NO.	Packaging	Volume
220129	bottle	1,0 L
220130	canister	10,0 L



Rims



• APP FE Cleaner Eco

Alkaline car wheel rim cleaning compound

APP FE Cleaner ECO - An alkaline preparation for use on car wheel rims made from light alloys, coated with lacquers and powder paints.

APP NO.	Packaging	Volume
220134	bottle	1,0 L
220135	canister	5,0 L



Rims



• APP M TAR Remover

Tar and asphalt removal compound

APP M TAR Remover is a preparation intended for removing traces of tar and asphalt, as well as tree resin, glue, and sticker residues. The compound is safe for car lacquers. It also removes lubricating substances from door hinges and locks. It comes ready to use right out of the container.

APP NO.	Packaging	Volume
220041	bottle	1,0 L



Bodywork

Engine

Rims



APP F Rust Remover

Compound for removing volatile rust from lacquered surfaces

APP F RUST Remover - A preparation for removing traces of volatile rust and metallic deposits from car bodywork and windshields. It can be used in its undiluted form or diluted in water in a max. 1:2 ratio.

APP NO.	Packaging	Volume
220116	bottle	1,0 L
220117	canister	10,0 L



Bodywork

Rims



APP Gum Remover

Compound rubber, glue and resin residue removal

APP GUM Remover - A preparation for removing stains on the car body and interior in the form of residues of adhesives (e.g. from stickers), tree resins or scratches caused by contact with rubber and plastics (e.g. seals, shoe soles). It removes grease, oils, dry spray, tar, asphalt, paraffin, resin and wax from vehicle interior and exterior surfaces. Check the effect on a non-visible surface before use. Do not use on PC plastic. Do not use on hot surfaces.

APP NO.	Packaging	Volume
220136	can	1,0 L
220137	canister	5,0 L



Bodywork

Interior



APP INSECT Remover

Insect removal compound

APP INSECT Remover - A concentrated and highly efficient preparation for removing insects from windshields, bodywork and plastic elements.

APP NO.	Packaging	Volume
220111	bottle	1,0 L
220112	canister	25,0 L



Concentrate

Bodywork

Windshields



APP M INSECT Remover

Insect removal compound

APP M INSECT Remover - A preparation for removing insects from the bodywork, windshields and mirrors and headlights of motor vehicles. The product contains active compounds responsible for removing the remains of dried up insects without damaging the cleaned surface. It is safe for lacquered surfaces, plastic elements and rubber, even when used often. The product should not be applied on heated car bodywork and should not be allowed to dry.

APP NO.	Packaging	Volume
220081	bottle with sprayer	650 ml



• APP M GLASS Cleaner

Windshield cleaning compound

APP M GLASS Cleaner – A highly efficient preparation intended for quick and effective cleaning of car windshields, mirrors, and all other glass surfaces. It removes nicotine and tar residues, remains of insects and silicone from preserving substances. It effectively removes road dirt and greasy stains. It significantly improves visibility while driving and does not require high labor input, leaving the surfaces shiny and free of smudges. The product is ready to use.

APP NO.	Packaging	Volume
220061	canister	5,0 L
220062	canister	10,0 L
220064	bottle with sprayer	650 ml



Windshields



• APP PS 50 Spray

Windshield washing and cleaning foam

APP PS 50 Spray is a professional foam for washing and cleaning windshields with a particularly effective formula that acts quickly and efficiently. The foam is designed to clean glass surfaces, i.e. windows, fireplace glass, oven glass, car windshields, mirrors and headlights.

➤ ADVANTAGES

- excellently removes road dirt and nicotine residues
- thanks to the inclusion of ammonia, it perfectly removes oil, tar and grease stains
- the foam's formula ensures its lasting adhesion to surfaces, enhancing its cleaning properties
- it does not leave traces and smudges in the cleaning location
- guarantees clean glass and improved visibility

APP NO.	Volume	Co.
212017	400 ml	12 pcs.



AUTO-CARE



Care and protection
preparations

233- 264 AUTO-CARE

- 233 - 238 Washing and cleaning preparations
- 239 - 242 • Care and protection preparations**
- 243 - 250 Sponges and brushes
- 251- 254 Microfiber cloths
- 255 - 260 Accesories - sprayers, applicators and dosing caps
- 261 - 264 Washing and cleaning devices

• APP QUARTZ Q895

2in1 leather upholstery care and maintenance compound

APP QUARTZ Q895 – A leather upholstery care and maintenance product. It contains avocado oil and lanolin. The compound also has cleaning properties and restores the color of cleaned surfaces. After use, the leather surface becomes softer, more flexible, and resistant to damage. The pleasant, natural aroma emphasizes the scent of leather. Can be used with any color of smooth leather.

➤ ADVANTAGES

- conditions and impregnates the upholstery
- cleans and restores leather color
- protects against drying and absorption of dirt
- leaves a silky shine

APP NO.	Packaging	Color / Type	Volume
220141	aerosol	transparent	250 ml



• APP Plast Care

Silicone-based compound for interior plastic care and maintenance

APP PLAST Care - A compound designed for the care and maintenance of car interior elements made from plastics (dashboard casing, cockpit, door paneling), and products made from faux-leather. Leaves a matt surface finish. Contains silicone.

APP NO.	Packaging	Volume
220114	bottle	1,0 L
220115	canister	5,0 L



• APP GM Care

Silicone-based compound for maintaining tires and exterior plastic elements

APP GM Care - A preparation for maintaining tires and non-lacquered exterior plastic elements, seals in doors and trunk and engine covers, side moldings, and bumpers. Contains silicone.

APP NO.	Packaging	Volume
220124	bottle	1,0 L
220125	canister	5,0 L

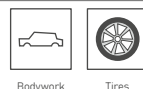

• APP SF Plastic Care

Silicone-free liquid for the care of plastic and rubber

APP SF Plastic Care - A compound intended for revitalization, care and maintenance of exterior and interior plastic elements, tires, moldings, bumpers, dashboard casings, cockpit, door paneling, and faux-leather products. The substance forms an insulating layer against water and dirt, giving elements a delicate, silky shine. Does not contain silicone.

APP NO.	Packaging	Volume
220164	bottle	1,0 L
220165	canister	25,0 L

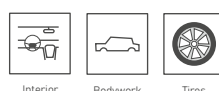

• APP M TIRE & PLASTIC Care

Tire and exterior plastic element care compound

APP M TIRE & PLASTIC Care – A product for the care and maintenance of exterior plastic and rubber vehicle elements. Excellently preserves and protects the tires, giving them a clear and silky shine. It rejuvenates plastic elements, restoring them to their original appearance. It is recommended for regular use, secures surfaces against adverse weather conditions. The product contains silicone.

APP NO.	Packaging	Volume
220082	bottle with sprayer	650 ml



• APP M COCKPIT PROTECT

Vehicle interior plastic care compound

APP M COCKPIT PROTECT - A cleaning and preserving compound recommended for maintaining cockpits and plastic elements in vehicle interiors. It forms a protective layer on the surface, preventing damage and adhesion of dirt. The product removes staining, restores surfaces, leaving a pleasant scent and matt surface finish.

APP NO.	Packaging	Volume
220083	bottle with sprayer	650 ml



• APP Cockpit Spray

Silicone-free vehicle cabin care compound

APP Cockpit Spray is a scented vehicle cabin cleaning and maintenance compound. It is designed for work on surfaces made of plastic, rubber, varnished wood and leather, e.g. dashboards, vinyl ceiling lining, rubber floor mats, etc.

➤ ADVANTAGES

- extends the service life of plastics, protects against dirt, static charges, moisture, and UV radiation
- prevents accumulation of dust
- restores colors, leaves an pleasant, orange scent
- gives a lasting, easy to maintain, delicate matt finish
- does not contain silicone

APP NO.	Volume	Sales units	Col.
212019	400 ml	pcs.	12 pcs.



• APP NANO GUARD CAR BODY

Set for long-term and effective car paintwork protection

APP Nano Guard Car Body – Coating the vehicle's lacquer with a layer of the preparation provides lasting and effective protection. The product forms a thin film on the lacquer surface, limiting the adverse effects of UV radiation, animal and plant deposits, and harmful weather conditions. It increases resistance to scratches. The compound hinders dirt adhesion, allowing it to be easily removed.

➤ ADVANTAGES

- simple application
- high efficiency
- long-lasting lacquer protection

APP NO.	Description
222015	The product forms a thin film on the lacquer surface, limiting the adverse effects of UV radiation, animal and plant deposits, and harmful weather conditions.



• APP NANO GUARD GLASS

Set for long-term and effective car windshield protection

APP Nano Guard Glass - Using the preparation makes the windshield surfaces smooth, which results in water and dirt washing down due to having lowered adhesion capabilities. The airflow when driving at a speed over 60 km/h blows the precipitation off the protected surface. This significantly increases visibility. Windshield wiper use is significantly limited or eliminated. As a result, driving safety is also improved.

➤ ADVANTAGES

- simple application
- high efficiency
- long-lasting windshield protection

APP NO.	Description
222025	Using the preparation makes the windshield surfaces smooth, which results in water and dirt washing down due to having lowered adhesion capabilities.



• APP NANO GUARD T TEXTILE

Set for long-term and effective car upholstery protection

APP Nano Guard T Textile - A preparation for long-term and efficient car upholstery protection. Coating the fabric with a layer of the compound provides long-lasting and efficient protection. The product forms a thin film around fabric fibers, limiting the impact of moisture, liquids, and staining fluids, minimizing the risk of stains. It also limits the activity of bacteria and fungi. The product does not restrict the breathability and flexibility of fabrics.

APP NO.	Packaging	Content
222030	bottle with sprayer	500 ml



• APP PURE

Car scents

The scents are intended for use inside vehicles, as well as in office interiors and households. After applying onto fabric upholstery, they leave a long-lasting effect of freshness, while also eliminating undesired odors. The scents are available in 50 ml glass with an atomizing dispenser.

APP NO.	Type	Volume	Col.
220090	set	30 x 50 ml	30 pcs.
220091	HAVANA CLUB	50 ml	1 pcs.
220092	VANILLA	50 ml	1 pcs.
220093	GENTLEMAN	50 ml	1 pcs.
220094	NEW CAR	50 ml	1 pcs.
220095	EGOIST	50 ml	1 pcs.
220096	VIP	50 ml	1 pcs.



AUTO-CARE



Sponges and brushes

233- 264 AUTO-CARE

- 233 - 238 Washing and cleaning preparations
- 239 - 242 Care and protection preparations
- 243 - 250 • Sponges and brushes**
 - 251- 254 Microfiber cloths
 - 255 - 260 Accesories - sprayers, applicators and dosing caps
 - 261 - 264 Washing and cleaning devices

• APP G1

Car bodywork washing sponge

APP G1 - A strong, CFT-free sponge characterized by a large size and high absorption, for universal applications.

APP NO.	Size	Color
220205	180 x 120 x 60 mm	yellow



Bodywork



• APP SMF

Car bodywork washing sponge with a two-sided microfiber layer

A multifunctional sponge designed for washing motor vehicle bodyworks. Thanks to a unique combination of a polyurethane foam with a layer of microfiber, the sponge constitutes a very efficient and durable washing tool. Due to its structure, it does not scratch the paintwork, while effectively removing dirt. The sponge's resilience ensures ideal adjustment to the bodywork shape, and the microfiber layer effectively gathers dirt. All these features make washing significantly faster and more efficient. The sponge's shape ensures a secure grip, and its absorptivity allows to wash large car surfaces.

➤ ADVANTAGES

- does not scratch the surface
- resilience and high absorptivity
- constant glide
- enhanced durability
- secure grip

APP NO.	Size	Color
220207	220 x 110 x 5 mm	yellow



Bodywork



• APP G2

Hard sponge for glass cleaning

APP G2 - A hard, CFT-free sponge for removing difficult and clingy dirt from the front windshield. Does not scratch the glass.

APP NO.	Size	Color
220210	110 x 70 x 36 mm	yellow



Windshields



Bodywork



• APP S2

Soft bodywork washing sponge

APP S2 - Soft, synthetic, low-density, open-cell sponge. Thanks to its structure, it is aggressive to dirt, while being gentle to delicate surfaces. It can be safely used on lacquered surfaces.

APP NO.	Size	Color
220211	165 x 110 x 55 mm	yellow



Windshields



Bodywork



- **APP G3**
Hard sponge for cleaning floor mats and upholstery

APP G3 - A sponge for removing persistent stains from floor mats and upholstery of motor vehicles.

APP NO.	Size	Color
220215	110 x 80 x 50 mm	yellow

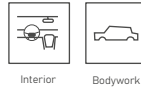

- **APP GCX**
Pressed cellulose sponge

APP GCX - A highly absorptive sponge designed for working with detergent-based washing products and matting pastes.

APP NO.	Size	Color
220201	110 x 35 x 5 mm	yellow

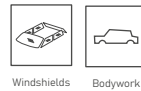

- **APP GB SB**
Sponge for care and maintenance compound application

APP GB SB - A sponge for applying care and maintenance products. The soft sponge is integrated with a rigid rubber grip.

APP NO.	Size	Color
220216	67 x 47 mm	black
220217	100 x 55 mm	black



- **APP TFA**
Sponge for care and maintenance compound application

APP TFA - A sponge for applying care and maintenance products. Used for thorough and precise distribution of preserving compounds of varying degrees of density, and all types of protective coatings. Thanks to its elasticity and soft, profiled working surface, the sponge adapts to any substrate. It adheres particularly well to the side surfaces of tires.

APP NO.	Size	Color
220218	100 x 38 x 59 mm	yellow + black



• APP Brush Soft

Soft bristle brush with adapter for cleaning upholstery

APP Brush Soft – A rotary brush with soft bristle, for cleaning fabric upholstery and floor mats. The brush features a corrosion-resistant adapter used to mount it on a drill or drill-driver. The APP Brush Soft significantly speeds up cleaning and its durable and flexible bristle does not degrade the fabric weaves. The brush's fitting is made from plastic and ensures precise and reliable operation, and an evenly distributed pressure on the entire cleaned surface. The bristle of this brush is made entirely from polypropylene resistant to all kinds of detergents.

➤ ADVANTAGES

- versatile use
- universal mounting adapter
- durable materials
- delicate bristle

APP NO.	Packaging
220236	The bristle of this brush is made entirely from polypropylene resistant to all kinds of detergents.

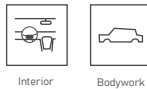

Interior

Bodywork



• APP Brush Set

Set of 3 cleaning brushes with adapters

APP Brush Set – A set of three rotary surface cleaning brushes. They feature a corrosion-resistant adapter designed for mounting on a drill or drill-driver. Using the brushes significantly speeds up cleaning of any surface. The durable and rigid bristle ensures precision and comfort during work. The bristle is made entirely from polyamide (nylon) resistant to all detergents, while the fittings are made from polypropylene. The rigid base enables reliable, precise work, and even distribution of pressure on the entire cleaned surface. The set will perform perfectly when cleaning heavily soiled surfaces. It is dedicated for cleaning certain elements of car upholstery and bodywork, including wheel rims and tires. It is also an indispensable tool in households. The brushes can be used for both wet and dry work.

➤ ADVANTAGES

- versatile use,
- universal mounting adapter,
- durable materials,
- three brush sizes.

➤ THE SET INCLUDES:

- 1 x brush with adapter – small, 50 mm diameter, bristle length 25mm,
- 1 x brush with adapter – large, 100mm diameter, bristle length 25mm,
- 1 x corner brush with adapter – 86mm diameter, bristle length max. 96 mm.

APP NO.	Set
220237	The brushes can be used for both wet and dry work.

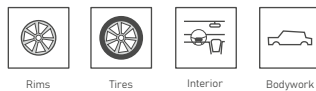

Rims

Tires

Interior

Bodywork



• APP SM

Cleaning brush with copper bristle

APP SM – A sharp copper brush for removing dirt from surfaces resistant to scratching, engines, tires.

APP NO.	Size	Color
220255	180 x 60 x 30mm	blue



Engine

Tires



• APP SWT

Floor mat and upholstery cleaning brush

APP SWT - A hard brush for manual washing and cleaning of floor mats and fabric or leather upholstery.

APP NO.	Size	Color
220260	150 x 120 x 60mm	blue



Interior



• APP LB Medium

Soft bristle brush for cleaning leather upholstery

APP LB Medium - A soft bristle brush for cleaning leather upholstery. It is dedicated for use on all types of leather surfaces. It excellently removes dirt from the pores and stitching, seams, creases and folds on the upholstery. The synthetic bristle does is not reactive with detergents used for cleaning and maintaining leather. Does not bleed its color onto the upholstery.

APP NO.	Size	Bristle
220263	122 x 40 x 29mm	synthetic



Interior



Seats



• APP LB Soft

Very soft bristle brush for cleaning leather upholstery

APP LB Soft - A very soft bristle leather upholstery cleaning brush. Dedicated for use on smooth and ventilated leather surfaces, as well as alcantara, suede, or nubuck. The brush with 8 rows of very densely packed bristle ensures thorough cleaning of surfaces while simultaneously protecting against scratches. It removes dirt from pores, stitching, seams, folds and creases on the leather upholstery. The brush does not bleed color, and the natural boar bristle is not reactive with detergents used in cleaning and maintaining leather.

APP NO.	Size	Bristle
220264	150 x 65 x 45mm	natural



Interior



Seats



• APP Rubber Brush

Animal hair gathering brush

APP Rubber Brush - A handy brush with long, rubber bristle. It allows to quickly and effectively deal with cleaning animal fur and hair off floor mats and fabric car upholstery. Practical, easy to use and safe for the cleaned surfaces. The brush is resistant to all liquids and detergents. It can be cleaned under running water.

➤ ADVANTAGES

- effective upholstery cleaning
- long and durable bristle
- ergonomic grip
- does not scratch the cleaned surface
- very durable

APP NO.	Size	Material
220266	165 x 50 mm	PP + TPR



Interior



• APP Wheel Brush

Wheel rim and narrow opening cleaning brush

APP Wheel Brush – A handy brush which will let you quickly and efficiently deal with cleaning wheel rims and difficult to reach areas. Equipped with an ergonomic, stiff, rubberized handle providing reliable grip. The brush can be hanged on a hook. The product is compatible with all compounds intended for wheel rim cleaning, including acids.

➤ ADVANTAGES

- ergonomic, rubberized handle
- bristle resistant to compounds dedicated for wheel rim cleaning
- large size
- does not scratch surfaces
- very durable

APP NO.	Total length:	Handle length:
220267	300 mm	165 mm



Rims



• APP PS1

Long bristle brush for cleaning gaps

APP PS1 – A brush with long, soft bristle that allows the user to reach and clean deep inside the smallest gaps.

APP NO.	Description
220270	A brush with long, soft bristle



Interior



• APP Clay Mitt

Bodywork decontamination mitt

APP Clay Mitt – A mitt with a polymer and microfiber surface. It is designed for mechanical removal of persistent and clingy dirt. The product enables cleaning of lacquered and glass surfaces (bodywork, windshields, headlights). The mitt does not damage surfaces and is very easy to use. It is intended for use on all types of top coat lacquers. The mitt's polymer surface reliably and quickly removes dirt. It performs excellently on both flat and embossed surfaces, as well as arches, convexities and concavities in vehicle bodies. For use during wet work.

➤ ADVANTAGES

- convenient to use
- does not cause scratches
- does not damage the surface
- does not leave smudges
- multiple use

APP NO.	Size	Material
220282	220 x 140 mm	microfiber



Bodywork



• APP CLAY BAR

Plastic mass
for cleaning smooth surfaces - clay

Plastic mass intended for mechanical removal of dirt from lacquered and glass surfaces such as car bodies, windshields, polycarbonate and glass headlights. Through adhesion, it reliably and quickly removes contaminants such as lacquering dry spray to facilitate polishing, industrial sediments, volatile rust, resin from trees, insect remains, etc. The product does not cause a decrease in gloss or other damage to the cleaned surface, is non-toxic, inflammable, easy to use, in specific cases can replace high granulation abrasive materials. The mass is designed for wet work.

➤ ADVANTAGES

- the blue APP Clay Bar mass has a more gentle effect and is designed for use on lacquers with lower hardness and in darker colors
- the red APP Clay Bar mass is more aggressive and is designed for use on hard lacquers and lacquers in brighter colors

APP NO.	Description	Color	Weight	Sales units	Col.
080802	aggressive	red	200g	pcs.	100 pcs.
080803	gentle	blue	200g	pcs.	100 pcs.



• APP SW Blade

Silicone squeegee / water wiper

The APP SW Blade water wiper is intended for initial and quick drying of vehicle bodywork. Thanks to its properties, it does not cause scratches on lacquered, glass or plastic surfaces

➤ ADVANTAGES

- comfortable to use and thorough
- does not cause scratches
- does not leave smudges
- made from soft silicone
- ergonomic grip

APP NO.	Size	Material	Col.
220287	300 x 97 mm	silicone	1 pcs.



• APP Grit Guard

Bucket dirt separator

APP Grit Guard - a specialized tool designed with the intention of limiting lacquer scratches caused during manual vehicle washing. For placing on the bottom of a washing and rinsing bucket. The APP Grit Guard prevents lifting of dirt particles when rinsing the washing sponge, brush or mitt, and the contaminants contained therein fall to the bottom of the bucket, without being transferred back onto the vehicle body. The bottom part of the separator features four dividers preventing agitation of water and raising of dirt particles.

APP NO.	Size	Color	Col.
220276	dia. 265 mm / height 65 mm	black	1 pcs.



AUTO-CARE



Microfiber cloths

233- 264 AUTO-CARE

- 233 - 238 Washing and cleaning preparations
- 239 - 242 Care and protection preparations
- 243 - 250 Sponges and brushes
- 251- 254 • Microfiber cloths**
- 255 - 260 Accessories - sprayers, applicators and dosing caps
- 261 - 264 Washing and cleaning devices

• APP Plush Towel

Microfiber car bodywork drying cloth

APP Plush Towel - An ideal solution for reliable and efficient drying of car bodywork surfaces. Its large surfaces and high quality of execution make the cloth absorb water and perform well wherever absolute delicateness is required. The heightened polyamide content increases the cloth's mechanical strength, which translates to increased service life.

➤ ADVANTAGES

- highly absorbent,
- plushy and dense microfibers,
- high-grade material.

APP NO.	Size	Surface density
080640	60 x 40 cm	1200 g/m ²



• APP QUARTZ Q806

Microfiber dust cloth

APP QUARTZ Q806 - is a specialized microfiber cloth made from very soft microfibers, designed for final polishing of lacquer. It is intended for removal of polishing paste residue and application and polishing of all kinds of shellac glazes, waxes or "quick detailers". The cloth's laser-trimmed edges are not hemmed with fabric, are very soft, and do not cause scratches on the lacquer. The APP QUARTZ Q806 cloth is very absorbent and can also be used for drying the car's body after washing.

➤ ADVANTAGES

- very soft
- dense fibers
- highly absorbent
- without additional hemming on the edges
- surface density 600 g/m²
- 80/20 polyester / polyamide

APP NO.	Color	Size	Col.
080646	navy blue	40 x 40 cm	1 pcs.



• APP MF Cloth

Microfiber dusting cloth

APP MF Cloth - A universal, high-grade, general purpose microfiber cloth. It works equally well for cleaning dry and wet surfaces. Can be washed mechanically in mild detergents, without the use of fabric softeners. Medium length fibers allow the cloth to clean, absorb dust, dirt, polishing paste residues and water many times more effectively than soft cotton or a cleaning towel.

➤ ADVANTAGES

- high quality,
- reusable,
- surface density 350 g/m².

APP NO.	Color	Size	Col.
080648	green	40 x 40 cm	3 pcs.





• APP MF Cloth

Microfiber dusting cloth

APP MF Cloth – A universal, high-grade, general purpose microfiber cloth. It works equally well for cleaning dry and wet surfaces. Can be washed mechanically in mild detergents, without the use of fabric softeners. Medium length fibers allow the cloth to clean, absorb dust, dirt, polishing paste residues and water many times more effectively than soft cotton or a cleaning towel.

➤ ADVANTAGES

- high quality,
- reusable,
- surface density 350 g/m².

APP NO.	Color	Size	Col.
080649	navy blue	40 x 40 cm	3 pcs.



• APP MF Cloth

Microfiber dusting cloth

APP MF Cloth – A high-grade microfiber cloth with different microfiber lengths. The side with longer fibers has a higher capacity for collecting dirt and polishing paste residues. The side with shorter fibers has a lower tendency to leave smudges on cleaned surfaces, and provides a better shine. It can be used for cleaning both dry and wet surfaces. Can be washed mechanically in mild detergents, without the use of fabric softeners.

➤ ADVANTAGES

- high quality,
- reusable,
- surface density 360 g/m².

APP NO.	Color	Size	Col.
080650	orange	40 x 40 cm	3 pcs.



• Product in use:



AUTO-CARE



Accesories – sprayers,
applicators and dosing caps

233- 264 AUTO-CARE

- 233 – 238 Washing and cleaning preparations
- 239 – 242 Care and protection preparations
- 243 – 250 Sponges and brushes
- 251- 254 Microfiber cloths
- 255 – 260 • Accesories – sprayers, applicators and dosing caps**
- 261 – 264 Washing and cleaning devices

- **APP SZP 1L**

Cleaning compound sprayer with pump

The sprayer allows for high cleaning compound savings and its even distribution on the cleaned car bodywork surface. The sprayer with a pump is chemically resistant to the effects of solvent-based cleaning products.

APP NO.	Description
251100	The sprayer with a pump is chemically resistant to the effects of solvent-based cleaning products.



- **APP ZU Set**

Seal set for the SZP 1L sprayer

The set is intended for periodic replacement of the factory installed seals degraded due to natural wear or damaged due to using inappropriate aggressive solvents (e.g. NITRO) in the sprayer.

APP NO.	Color	Set
251101	green	o-ring 36,0 x 4,0 - 1 pcs. o-ring 14,0 x 3,5 - 1 pcs. o-ring 3,0 x 2,7 - 1 pcs. o-ring 5,0 x 1,5 - 3 pcs. seal - 1 pcs.



- **APP SDD**

Water and detergent sprayer

The advantage of using a sprayer is the ability to quickly apply detergent and water mixtures onto large surfaces.

APP NO.	Material	Volume	Sales units
251106	PE	1,0 L	pcs.



- **APP Trigger 1**

Sprayer pump

A manual sprayer with single-action operation, intended for detergents, water, and non-aggressive chemicals. It is characterized by very high manufacturing quality and efficiency. The pump's output is approx. 1,20 ml of liquid. The sprayer features a nozzle with an adjustable spray angle. It is perfect for detailing works with diluted solutions. The suction tube is fitted with a liquid filter.

APP NO.	Description
251102	The sprayer features a nozzle with an adjustable spray angle. It is perfect for detailing works with diluted solutions. The suction tube is fitted with a liquid filter.



• APP Trigger 2

Sprayer pump

A modern, manual sprayer designed for applying and dispersing liquids, including solutions of cleaning compounds, and for applying car care products. .



➤ ADVANTAGES

- Viton seal with heightened resistance to the effects of aggressive chemicals
- double-action pump construction – pumps during lever motion in both directions (push and release)
- adjustable nozzle allowing to change the stream from focused to highly dispersed
- installed filter for the pumped liquid
- pump output in two motions – approx. 3 ml of liquid
- durability approx. 40000 work cycles (parameter determined during work with demineralized water)



APP NO.	Description
251103	pump output in two motions – approx. 3 ml of liquid

• APP AD 3000

Pressure sprayer with lance

The AD 3000 3L pressure sprayer with a lance is a professional device for washing, cleaning, decontamination, neutralization, and application of impregnating compounds and other chemical compounds containing acids and corrosive substances. The incorporated Viton seal is non-reactive to chemically aggressive and non-neutral agents.



APP NO.	Description
251109	It is intended for applying detergents onto large surfaces, e.g. car bodyworks, workshop floors. It is not compatible with paint cleaners, e.g. W900.



• APP PP HDPE

Auxiliary container with graded scale, top cap and seal

HDPE auxiliary containers with a graded scale and cap. The APP No. 250209 auxiliary container is equipped with a rubber seal which additionally secures the container. There is a possibility to stack the sealed containers on a pallet.



APP NO.	Color / Option	Volume	Sales units	Col.
250204	transparent	0,25 L	pcs.	300 pcs.
250205	transparent	0,50 L	pcs.	300 pcs.
250206	transparent	1,0 L	pcs.	180 pcs.
250207	transparent	0,15 L	pcs.	360 pcs.
250208	transparent	5,0 L	pcs.	32 pcs.



• APP B-Neck

Long-necked bottle + cap

APP B-Neck is an ergonomic, long-neck bottle with an included cap, made from polyethylene PE, with a capacity of 1,0 L. The bottle is designed for storing all kinds of detergents and water. The APP B-Neck is compatible with triggers available in the AP offer (APP No. 251102 and 251103).



APP NO.	Material	Volume	Sales units
251112	PE	1,0 L	pcs.



- **APP Screw Cup DIN 45**

Dosing cap with a tap

The APP Screw Cup DIN 45 (inner inlet diameter 34,5 mm) is a dosing cap with a tap for use with 5 L and 10 L capacity canisters in order to dispense concentrates, which facilitates pouring liquids from large containers. The cap features an inner seal which additionally secures the canister.

APP NO.	Description
220198	The cap features an inner seal which additionally secures the canister.



- **APP Screw Cup DIN 51**

Dosing cap with a tap

The APP Screw Cup DIN 51 (inner inlet diameter 43,6 mm) is a dosing cap with a tap for use with 5 L and 10 L canisters in order to dispense concentrates, which facilitates pouring liquids from large containers. The cap features an inner seal which additionally secures the canister.

APP NO.	Description
220196	The cap features an inner seal which additionally secures the canister.



- **APP Screw Cup DIN 61**

Dosing cap with a tap

The APP Screw Cup DIN 61 (inner inlet diameter 48,5 mm) is a dosing cap with a tap for use with 25 L and 30 L canisters in order to dispense concentrates, which facilitates pouring liquids from large containers. The cap features an inner seal which additionally secures the canister.

APP NO.	Color / Option
220199	The cap features an inner seal which additionally secures the canister.



- **Product in use:**



• APP Micro Brush

Touch-up brush sticks with applicator

The APP Micro Brush are disposable, non-dusting sticks for performing paint touch-ups. The sticks are made from plastic and the paint applicator is made from a nonwoven fabric. The APP Micro Brush sticks are designed for applying any type of paint or lacquer while performing repairs of small chips in the paint coating.

➤ ADVANTAGES

- non-dusting applicator material
- three different applicator sizes: 1,0 mm – white, 1,5 mm – yellow, 2,0 mm – blue
- precise paint and lacquer application
- ergonomic shape and small weight
- tightly sealed packaging



APP NO.	Color	Size	Sales units
250228	white	1,0 mm	pack. 100 pcs.
250229	yellow	1,5 mm	pack. 100 pcs.
250230	blue	2,0 mm	pack. 100 pcs.

• APP ZPW

Touch-up brush set

Brushes from natural bristle.

APP NO.	Description	Sales units
250008	For very small and precise repairs of paint defects.	set 3 pcs.



• APP TPP20

Touch-up paint container

The APP TPP20 2in1 touch-up paint container is a product intended for storing paint or lacquer featuring a small brush for performing touch-ups, and a rapidograph. The 2in1 bottle, thanks to a special needle, allows application of a consistently thick line on any location on the car's body.

➤ ADVANTAGES

- small volume – 20 ml
- 2in1 packaging
- glass ball to facilitate mixing
- brush for precise application
- rapidograph for filling scratches
- ergonomic shape (imitating a marker)
- can be hung
- cap with needle protection



APP NO.	Type	Volume	Sales units
250226	2 in 1	20 ml	pack. 10 pcs.

• APP TPB20

Touch-up paint container with brush and mixing ball

The APP TPB20 touch-up paint container is a product intended for storing paint or lacquer, featuring a brush for performing touch-ups and a metal ball for thoroughly mixing the container's contents. The brush is made from synthetic bristle, is very delicate and is designed for precise application.

➤ ADVANTAGES

- small volume – 20 ml
- screw cap providing additional sealing
- metal ball to facilitate mixing
- brush for precise application

APP NO.	Volume	Sales units
250227	20 ml	pack.100 pcs.
250237	20 ml	pack.10 pcs.



AUTO-CARE



Washing and cleaning
devices

233- 264 AUTO-CARE

- 233 - 238 Washing and cleaning preparations
- 239 - 242 Care and protection preparations
- 243 - 250 Sponges and brushes
- 251- 254 Microfiber cloths
- 255 - 260 Accessories - sprayers, applicators and dosing caps
- 261 - 264 • Washing and cleaning devices**

• NTools CG1000

Pneumatic cleaning gun

NTools CG1000 – A specialized, pneumatic device for effective dry and wet cleaning of all types of soiling from car bodywork and interiors – plastic elements, seats, upholstery, floor mats, and all kinds of persistent dirt and staining. During “dry work”, it kicks up dust and contaminants. During “wet work”, thanks to a specially shaped nozzle with a spinning core, it creates a foamy cleaning solution under the influence of compressed air, which cleans all elements, dampening them to a minor degree. The NTools CG1000 is an effective and efficient tool that uses minimal amounts of water and detergents. The NTools CG1000 can reach all difficult to access areas, gaps, and anywhere a regular sponge, cloth, or brush cannot reach.

APP NO.	Description
231710	The NTools CG1000 can reach all difficult to access areas, gaps, and anywhere a regular sponge, cloth, or brush cannot reach.



• NTools FG1000

Pneumatic foam generator

NTools FG1000 – a pneumatic device designed for generating foam from cleaning products. It is excellent for applying preparations both on a car's bodywork, as well as upholstery and wherever it is necessary to limit water consumption.

APP NO.	Description
231708	Thanks to special nozzles, the foam is compact and uniform, and the simplicity of application ensures even distribution on the cleaned areas.



• APP Twister Gun

Pneumatic cleaning gun

APP Twister Gun – A specialized pneumatic tool for effective cleaning of all types of dirt and contaminants on both exteriors and interiors of vehicles. The APP Twister Gun is an innovative device with a specially shaped nozzle with a spinning, aluminum inner core. The core is specially mounted ensuring the nozzle's protection against wear from the inside, which significantly extends its service life. Under the influence of compressed air, the device generates a mist used to clean selected elements. The compound amount can be adjusted, allowing full control over the dispensed dosage. The APP Twister Gun is a highly efficient device. It uses minimal amounts of detergents and only slightly dampens the cleaned element, significantly decreasing drying time. It is intended for everyday use at car service stations, workshops and car washes. It is perfectly compatible with compounds in the APP offer, i.e. Multi Cleaner and Inner Cleaner.

APP NO.	Description
231709	The product is ideally suited for cleaning car bodywork elements, the engine compartment, wheel rims, air intakes, plastic elements, seats, upholstery, floor mats, ceiling linings, and all kinds of difficult to reach areas.



• APP W0CG

Rotating hose for CG1000

A rotating rubber hose designed as a replacement part for the APP CG1000 device.

APP NO.	Description
231712	replacement parts

• NTools CT-1000CUP

Twister Gun container cap

A plastic screw cap – replacement part for the APP Twister Gun.

APP NO.	Description
231713	replacement parts

• APP WW CG

Cleaning gun rotating hose insert

An insert for the rotating hose – replacement part for the APP CG1000 device.

APP NO.	Description
231716	replacement parts

• APP Twister Gun CT-1000BOT

1000 ml container for the APP Twister Gun

A 1000 ml PE container – replacement part for the APP CG1000 and APP Twister Gun devices.

APP NO.	Description
231717	replacement parts

• APP A0TG

Rotating adapter for the APP Twister Gun

An aluminum rotating adapter – replacement part for the APP Twister Gun.

APP NO.	Description
231718	replacement parts

• APP Twister Gun APP DTG

Rotating adapter for the APP Twister Gun

An aluminum rotating adapter – replacement part for the APP Twister Gun

APP NO.	Description
231719	replacement parts

• APP WDW

Twister Gun rotating hose insert

An insert for the rotating hose – replacement part for the APP Twister Gun device.

APP NO.	Description
231721	replacement parts



SMART REPAIR



NSK windshield
repair

265- 304 SMART REPAIR

- 265 – 268 • **NSK windshield repair**
- 269 – 274 Repair and lacquering of leather and plastics
- 275 – 278 Repair of plastic parts damage / welding
- 279 – 304 PDR – Paint-less dent repair
 1. PDR Lamps
 2. Hammers mallets
 3. Glue method - PULL:
 - pullers and inertia hammers
 - suction cups
 - tabs / adapters
 - hot-melt glues
 4. PUSH method:
 - kits
 - push wires
 - PDR accessories
 - stands, cards

- **APP NSK**

Glued windshield repair kit

A toolkit for repairing glued car windshields enabling removal of damage usually caused as a result of stone impacts against the vehicle's front windshield. Repair using the NSK kit restores the windshield's original technical and optical parameters.

APP NO.	Packaging
220500	Repair using the NSK kit restores the windshield's original technical and optical parameters.



- **APP NSK 919 S**

Filling resin packet

Filling resin for repairing glued car windshields in the NSK system. The packet includes a tube containing 1 ml of resin, which allows to perform 5-6 repairs, depending on the extent of damage.

APP NO.	Description
220505	filling resin



- **APP NSK 919 B**

Bottled filling resin

Filling resin for repairing glued car windshields in the NSK system. The bottle contains 15 ml of resin, which allows to perform over 75 windshield repairs.

APP NO.	Description
220506	filling resin



- **APP NSK 3200**

Injector

An injector (cylinder with a plunger) for injecting the filling resin into the damaged location.

APP NO.	Description
220510	injector (cylinder with a plunger)



- **APP NSK 943 L**

Finishing resin

A hard resin for finishing windshield repair surfaces in the NSK system. The bottle contains 1,5 ml of resin, which allows to perform up to 20 repairs, depending on the extent of damage.

APP NO.	Description
220515	finishing resin



• APP NSK 943 XL

Finishing resin

A hard resin for finishing windshield repair surfaces in the NSK system. The bottle contains 15ml of resin, which allows to perform as many as 200 repairs, depending on the extent of damage.

APP NO.	Description
220516	finishing resin



• APP NSK 934

Carbide drill bit

A drill bit from sintered carbides for pre-drilling the repair location in star-shaped and combination-star-shaped cavities.

APP NO.	Description
220520	carbide drill bit



• APP NSK 634

Crack repair resin

A resin for repairing windshield cracks in the NSK system.

APP NO.	Description
220540	crack repair resin



• APP NSK 949

Repair area polishing paste

A milky compound designed for spot polishing of the windshield repair area in the NSK system.

APP NO.	Description
220545	milky compound designed for spot polishing



• APP NSK 970

Mylar foil

A Mylar foil used for finishing windshield repair surfaces. Used in combination with the NSK 943 L / NSK 943 XL finishing resin. Package contains 10 pcs.

APP NO.	Description
220525	mylar foil



• APP NSK BRIDGE

Plastic injector bridge

A bridge with a rubber suction cup. It is designed for precise injector installation directly over the damaged location during windshield repairs.

APP NO.	Description
220550	a bridge with a rubber suction



• APP LAMP UV

12V UV lamp

An ultraviolet lamp with a timed off switch, enabling the curing of resins during glued windshield damage repairs. Powered by 12 V voltage from the car lighter socket or, if a lighter is not present, by connecting to a 230V to 12V voltage converter (APP No. 351882).

APP NO.	Description
220555	an ultraviolet lamp



• APP NSK FELT

Polishing felt

A felt on a metal pin for finishing (polishing) the repaired windshield damage. It is compatible with a mini-drill in the NSK set.

APP NO.	Description
220560	a felt on a metal pin for finishing (polishing)

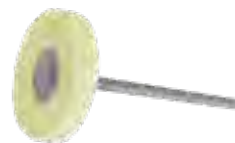

• APP GEL100

Suction cup sealing gel

A gel for precise sealing of suction cups in order to ensure stronger adhesion to surfaces. It enables precise placement of a bridge, mirror, or UV lamp from the NSK set.

APP NO.	Description
220565	suction cup sealing gel



• NTools PDR A13

230V to 12V voltage converter

A converter enabling conversion of 230V input voltage to 12V output voltage. It ensures the ability to connect devices powered from a 12V car lighter socket.

APP NO.	Description
351882	230V to 12V voltage converter



SMART REPAIR



Repair and lacquering
of leather and plastics

265- 304 SMART REPAIR

- 265 - 268 NSK windshield repair
- 269 - 274 • Repair and lacquering of leather and plastics**
- 275 - 278 Repair of plastic parts damage / welding
- 279 - 304 PDR - Paint-less dent repair
 1. PDR Lamps
 2. Hammers mallets
 3. Glue method - PULL:
 - pullers and inertia hammers
 - suction cups
 - tabs / adapters
 - hot-melt glues
 4. PUSH method:
 - kits
 - push wires
 - PDR accessories
 - stands, cards

- **APP NTW Color**

Lacquer set for leather and vinyl

NTW KOLOR is a set of water-based, high-opacity lacquers characterized by excellent elasticity and adhesion to natural leather and plastic surfaces used in vehicles. The set contains 9 pigments and 3 colorless lacquers and allows to obtain a wide range of colors. The color chart and weight formulas facilitate obtaining the desired lacquer color.

APP NO.	Description
220650	set



- **APP NTW Black**

Leather and vinyl pigment

The NTW Black pigment is a water-based, high-opacity lacquer with high elasticity and adhesion to natural leather and plastic surfaces used in vehicles.

APP NO.	Packaging	Volume
220652	bottle	250 ml



- **APP NTW Silver**

Leather and vinyl pigment

The NTW Silver pigment is a water-based, high-opacity lacquer with high elasticity and adhesion to natural leather and plastic surfaces used in vehicles.

APP NO.	Packaging	Volume
220654	bottle	250 ml



- **APP NTW Red Oxide**

Leather and vinyl pigment

The NTW Red Oxide pigment is a water-based, high-opacity lacquer with high elasticity and adhesion to natural leather and plastic surfaces used in vehicles.

APP NO.	Packaging	Volume
220656	bottle	250 ml



- **APP NTW Indo Yellow**

Leather and vinyl pigment

The NTW Indo Yellow pigment is a water-based, high-opacity lacquer with high elasticity and adhesion to natural leather and plastic surfaces used in vehicles.

APP NO.	Packaging	Volume
220658	bottle	250 ml



- **APP NTW Quindo Red**
Leather and vinyl pigment

The NTW Quindo Red pigment is a water-based, high-opacity lacquer with high elasticity and adhesion to natural leather and plastic surfaces used in vehicles.

APP NO.	Packaging	Volume
220660	bottle	250 ml



- **APP NTW Thalo Blue**
Leather and vinyl pigment

The NTW Thalo Blue pigment is a water-based, high-opacity lacquer with high elasticity and adhesion to natural leather and plastic surfaces used in vehicles.

APP NO.	Packaging	Volume
220662	bottle	250 ml



- **APP NTW White**
Leather and vinyl pigment

The NTW White pigment is a water-based, high-opacity lacquer with high elasticity and adhesion to natural leather and plastic surfaces used in vehicles.

APP NO.	Packaging	Volume
220664	bottle	250 ml



- **APP NTW Thalo Green**
Leather and vinyl pigment

The NTW Thalo Green pigment is a water-based, high-opacity lacquer with high elasticity and adhesion to natural leather and plastic surfaces used in vehicles.

APP NO.	Packaging	Volume
220666	bottle	250 ml



- **APP NTW Yellow Oxide**
Leather and vinyl pigment

The NTW Yellow Oxide pigment is a water-based, high-opacity lacquer with high elasticity and adhesion to natural leather and plastic surfaces used in vehicles.

APP NO.	Packaging	Volume
220670	bottle	250 ml



- **APP NTW H Gloss**

Colorless lacquer, gloss

The NTW H-GLOSS colorless lacquer is a water-based lacquer characterized by high-elasticity and adhesion to natural leather and plastic surfaces used in vehicles. It increases the coated surface's resistance to scratching and cracking. It allows to obtain a high gloss surface finish.

APP NO.	Packaging	Volume
220672	bottle	250 ml



- **APP NTW S Gloss**

Colorless lacquer, semi-gloss

The NTW S-GLOSS colorless lacquer is a water-based lacquer characterized by high-elasticity and adhesion to natural leather and plastic surfaces used in vehicles. It increases the coated surface's resistance to scratching and cracking. It allows to obtain a semi-gloss surface finish.

APP NO.	Packaging	Volume
220674	bottle	250 ml



- **APP NTW L Luster**

Colorless lacquer, matt

The NTW L-LUSTER colorless lacquer is a water-based lacquer characterized by high-elasticity and adhesion to natural leather and plastic surfaces used in vehicles. It increases the coated surface's resistance to scratching and cracking. It allows to obtain a matt surface finish.

APP NO.	Packaging	Volume
220676	bottle	250 ml



- **APP NTW WZ**

Color chart

A set of several hundred colors and shades for leather upholstery and plastic vehicle interior elements. It allows to select the appropriate color formula.

APP NO.	Description
220682	color chart



- **APP NTW AP**

Pigment adhesion activator

A preparation that increases pigment adhesion to surfaces and enhances the resistance of applied lacquer to the effects of chemical compounds used in upholstery cleaning.

APP NO.	Packaging	Volume
220678	bottle	118 ml



- **APP WG 100**

Precise scale

A scale with a maximum load of 100g.

APP NO.	Description
220684	it weighs with an accuracy to 0.01 g. Powered by two AAA batteries (not included with the device).



- **APP NTW Formula**

Leather lacquer mixing formulas

A compilation of all available leather upholstery and plastic car interior element colors.

APP NO.	Description
220680	it provides the amounts of pigments comprising the given lacquer colors by weight.



- **APP NTW 40**

Natural leather crack filler emulsion

An emulsion for filling surface cracks on the face of natural leather.

APP NO.	Description
220630	a one-component (1K) water-based product that dries naturally in approx. 20 minutes when applied in a thin layer.



- **APP NTW 10**

Colorless filler

A colorless filler for repairing hard car interior plastics. It allows to repair cavities.

APP NO.	Description
220612	hardens within several dozen seconds in contact with a thin layer of the NTW 1012 curing agent. Durable and hard.



- **APP NTW 12**

Black filler

A black colored filler for repairing hard car interior plastics. It allows to recreate the structure of the repaired surface. Lower durability balanced by easier recreation of the original material structure.

APP NO.	Description
220614	hardens within several dozen seconds in contact with a thin layer of the NTW 1012 curing agent.



• **APP NTW 1012**
Filler curing agent

An aerosol curing agent for the NTW 10 and NTW 12 fillers. It enables their chemical hardening through application of a thin layer and a few dozen seconds of contact.

APP NO.	Packaging	Volume
220616	bottle	250 ml



• **APP NTW 20**
Gel filler

A filler in the form of gel for repairing elastic car interior materials (vinyl, leather). The compound hardens when exposed to a temperature of 160°C for 3-4 second periods of heating and 20-30 second intervals between subsequent heating periods (heat gun, flatiron).

APP NO.	Packaging	Volume
220618	bottle	250 ml



• **APP NTW 30**
Mold mass

A mold mass for recreating the surface structures of plastic car interior elements. It is a two-component product. After thoroughly mixing the components, applying a thin layer on the surface template, a faithful recreation of the template (impression) for multiple uses is obtained after about 10 minutes.

APP NO.	Packaging	Volume
220620	bottle	50 ml



• **APP NTW 32**
Small stirring tips

Stirring tips for the NTW 30 mold mass. An interior labyrinth structure allows thorough mixing of components from an extruded 2K cartridge.

APP NO.	Description
220622	they are compatible with 50 ml capacity, two-component dispensers. The package contains 12 units



• **NTools APL**
Manual 2K 2x25ml cartridge extruder

A manual applicator for the simultaneous and precise extrusion (1:1) of 2x25ml cartridges.

APP NO.	Description
220623	the extruder has dedicated APP NTW 32 mixing tips



• **APP NTW Spray**
Template

The NTW Spray template is executed in a spray-on technology from products whose color and structure it recreates. These products are: Bumper Paint Color Spray and Structure Paint Spray.

➤ **ADVANTAGES**

- made using spray-on technology
- recreates real colors and structures

APP NO.	Description
220691	template



SMART REPAIR



Repair of plastic parts
damage / welding

265- 304 SMART REPAIR

- 265 – 268 NSK windshield repair
- 269 – 274 Repair and lacquering of leather and plastics
- 275 – 278 • Repair of plastic parts damage / welding**
- 279 – 304 PDR – Paint-less dent repair
 1. PDR Lamps
 2. Hammers mallets
 3. Glue method - PULL:
 - pullers and inertia hammers
 - suction cups
 - tabs / adapters
 - hot-melt glues
 4. PUSH method:
 - kits
 - push wires
 - PDR accessories
 - stands, cards

• NTools Plastic Welding Set

Plastic element welding set

A set for welding plastic materials through the use of appropriate binders selected depending on the repaired element. The high quality of the NTZ 995 aluminum mesh (elastic, stainless) is ideally suited to rebuilding, e.g. hitches or all kinds of cavities in elements. Its use during repair results in an increase in durability of surfaces exposed to high pressure.

The set includes an aluminum roll on the handle FP Roll APP (APP No. 220715) to facilitate forming, restoring and changing the shape of the materials made of thermoplastic materials.

APP NO.	Description
220330	The system enables repair of cracks and scratches and its recommended use is repair of bumpers, headlight attachments, fluid tanks, exterior plastics and vehicle interior elements. The set contains the FP Roll aluminum roller on a handle that facilitates formation, restoration and change of the shape of thermoplastic materials.



• APP FP PP

Triangular polypropylene wire

A triangular PP wire – an electrode with a triangular section, for welding elements made from polypropylene, e.g. bumpers, headlight housings, grills, and vehicle interior elements.

APP NO.	Material	Volume
220721	PP	100 g



• APP FP PP+EPDM

Triangular PP+EPDM wire

A triangular PP+EPDM wire – an electrode with a triangular section, for welding elements made from polypropylene with the addition of EPDM, e.g. bumpers, headlight housings, grills, and vehicle interior elements.

APP NO.	Material	Volume
220726	PP-EPDM	100 g



• APP FP PEHDPE

Triangular polyethylene wire

A triangular PE (HDPE) wire – an electrode with a triangular section, for welding elements made from polyethylene, e.g. consumable fluid tanks.

APP NO.	Material	Volume	Col. pack.
220731	PE (HDPE)	100 g	1 pcs.



• APP FP PC

Triangular polycarbonate wire

A triangular PC wire – an electrode with a triangular section, for welding elements made from polycarbonate, e.g. bumpers, headlight housings, vehicle interior elements.

APP NO.	Material	Volume	Col. pack.
220736	PC	100 g	1 pcs.



- **APP FP ABS**
Triangular ABS wire

A triangular ABS wire - an electrode with a triangular section.

APP NO.	Description
220741	for welding elements made from polyamide (nylon), e.g. radiator tanks, fenders, grills, and vehicle interior elements



- **APP FP PA**
Triangular nylon wire

A triangular PA wire - an electrode with a triangular section.

APP NO.	Description
220746	for welding elements made from polyamide (nylon), e.g. radiator tanks, fenders, grills, and vehicle interior elements



- **APP NTZ 995**
Aluminum mesh

Aluminum mesh for embedding in the damaged plastic area. Flexible, corrosion-resistant and durable. It allows to rebuild plastic cavities and hitches. It improves the durability of a weld or restored fragment.

APP NO.	Material	Size	CoL. pack.
220317	aluminum	140 x 1500 mm	1 pcs.



- **APP FP ROLL**
Roller on a handle

An aluminum roller mounted on an ergonomic handle. The tool facilitates formation, restoration and shape change of elements made from thermoplastic materials.

APP NO.	Packaging
220715	most often used to straighten crushed corners of bumpers



- **NTools Hot Stapler Set**
Plastic welding / hot stapling set

A set designed for hot-welding plastic materials by embedding staples and joining the damaged elements. The set includes a 230V powered device with three-stage amperage adjustment an ergonomic handle (on an elastic cable) for mounting the staples embedded in the repaired thermoplastic material. It enables repair of plastics characterized by different hardness levels, thickness, and plasticization temperatures. The grip allows to mount staples at three different angles, making it possible to reach even difficult areas.

APP NO.	Description
220760	The set contains six types of stainless steel staples (flat, undulated, outer corner, inner corner, 0,6 and 0,8 mm thick) in 100 unit packages, and front cutters for trimming staple fragments protruding after embedding in the repaired plastic.



- **NTools FS06**

Staple set - flat

Flat staples from stainless steel, with a thickness of 0,6 mm, intended for embedding across a crack. Used in repairing thin-walled materials and in areas with lower strength parameters.

APP NO.	Type	Thickness	Col. pack.
220761	flat	0,6 mm	100 pcs.



- **NTools FS08**

Staple set - flat

Flat staples from stainless steel, with a thickness of 0,8 mm, intended for embedding across a crack. Used in repairing thick-walled materials and in areas with higher strength parameters.

APP NO.	Type	Thickness	Col. pack.
220762	flat	0,8 mm	100 pcs.



- **NTools WS06**

Staple set - undulated

Undulated staples from stainless steel, with a thickness of 0,6 mm, intended for embedding along a crack. Used in repairing thin-walled materials and in areas with lower strength parameters.

APP NO.	Type	Thickness	Col. pack.
220763	undulated	0,6 mm	100 pcs.



- **NTools WS08**

Staple set - undulated

Undulated staples from stainless steel, with a thickness of 0,8 mm, intended for embedding along a crack. Used in repairing thick-walled materials and in areas with higher strength parameters.

APP NO.	Type	Thickness	Col. pack.
220764	undulated	0,8 mm	100 pcs.



- **NTools CS08**

Staple set - inner corner

Stainless steel staples with a thickness of 0,8 mm, intended for embedding in the inner side of an element's corner.

APP NO.	Type	Thickness	Col. pack.
220765	inner corner	0,8 mm	100 pcs.



- **NTools Hot Stapler Small**

Plastic material hot-stapling / welding set

ZA set designed for hot-welding plastic materials by embedding staples and joining the damaged elements. A 230V powered device with an integrated handle for mounting staples embedded in the repaired thermoplastic material. The set includes four types of 0,8 mm thick staples (flat (40 pieces), undulated (20 pieces), outer corner (20 pieces) and inner corner (20 pieces)).

APP NO.	Description
220759	the set features a welding and cutting tip used to smooth out and shape the surface during repair



- **NTools OCS06**

Staple set - outer corner

Stainless steel staples with a thickness of 0,6 mm, intended for embedding in the outer side of an element's corner.

APP NO.	Type	Thickness	Col. pack.
220766	outer corner	0,6 mm	100 pcs.



SMART REPAIR



PDR – Paint-less dent repair

265– 304 SMART REPAIR

- 265 – 268 NSK windshield repair
- 269 – 274 Repair and lacquering of leather and plastics
- 275 – 278 Repair of plastic parts damage / welding
- 279 – 304 • **PDR – Paint-less dent repair**
 1. PDR Lamps
 2. Hammers mallets
 3. Glue method - PULL:
 - pullers and inertia hammers
 - suction cups
 - tabs / adapters
 - hot-melt glues
 4. PUSH method:
 - kits
 - push wires
 - PDR accessories
 - stands, cards

1. PDR Lamps

• NTools LC 420

6-LED PDR shadow lamp with suction cup

A shadow lamp designed for work during paint-less vehicle bodywork repair in the PDR system. The lamp's reflection (with a length of 420 mm and width of 185 mm) in the dent area facilitated interpretation of the defect shape, allowing to make a decision on further repair procedures. Three lines of led strips with the ability to activate each separately and choose warm or cold light for each line.

➤ ADVANTAGES

- mobile
- light (1,6 kg)
- high battery capacity
- separate power adapter
- secured housing edges

APP NO.	Description
351910	Possible 230V power supply, and 12V using a gel battery. The set includes a charger, adapter and extension cord.



• NTools LC 1050 2.0

Shadow lamp on a stand

A shadow lamp designed for work during paint-less vehicle bodywork repair in the PDR system. The lamp's reflection (with a length of 1050 mm and width of 185 mm) in the dent area facilitates interpretation of the defect shape, allowing to make a decision on further repair procedures. Three lines of LED strips with the ability to activate each separately and choose warm or cold light in each line. The main power and dimmer switch are remote controlled. Possible 230V power supply, and 12V using a gel battery. The set includes a charger, a power adapter and extension cord.

➤ ADVANTAGES

- high mobility
- high battery capacity (12V 12Ah)
- remote controlled light intensity adjustment
- velour lamp edge protection
- 4 pivoting wheels with brakes
- large, ergonomic handles and knobs

APP NO.	Description
351915	The lamp features a stand allowing adjustment according to the operator's needs and setting it at any angle in the appropriate location.



• NTools LC 1050 2.0 STAND

Shadow lamp stand

A stand designed for mounting PDR lamps used while performing paint-less vehicle bodywork repairs. It features 4 pivoting wheels (all with brakes) providing the operator with high mobility during work. The lower section of the stand is intended for holding the battery powering the lamp. To obtain greater stability, it is possible to also extend the front base.

➤ ADVANTAGES

- high mobility
- large and ergonomic handles and knobs,
- 4 pivoting wheels with brakes.
- accessory shelf.
- additional foam for bodywork protection

APP NO.	Description
351917	The frame section's polyethylene cover protects the car's bodywork against scratching.



• NTools PDR UP75

Suction holder for the LC420 shadow lamp

The NTools PDR UP75 suction holder is a 75 mm diameter rubber suction plate with a pump.

APP NO.	Packaging
351890	used for stable mounting of the LC420 lamp to a vehicle's bodywork during paint-less dent repair



• NTools PDR PM

3/4" modular joint for the NTools LC 420 lamp

The NTools PDR PM3/4 modular joint is a modular arm consisting of 14 segments with mounting endings.

APP NO.	Packaging
251319	the joint serves as an arm for the LC420 lamp and allows to adjust it in any way at a chosen angle during work



2. Hammers and mallets

• NTools PDR Carbon Hammer

Blending hammer with replaceable heads and extender

The NTools PDR Carbon Hammer is a hammer for blending – leveling or de-stressing hills on vehicle bodies caused by performing repairs using the PDR technique. The NTools PDR Carbon Hammer set includes two heads. The first is made from stainless steel with a polished surface. It has an oval shape and is dedicated for blending. The second is made from a refined PA (polyamide) plastic with a sharp, rounded end that allows to even out unevenness with a smaller surface area and less gentle characteristics. The set contains an extended designed to increase the hammer's length by 20 cm. It allows to level unevenness visible only at a larger distance.

➤ ADVANTAGES

- polished and replaceable heads
- light construction
- comfortable to use
- properly balanced
- additional extender included

APP NO.	Description
351920	The hammer's handle is made from a light, yet highly durable carbon fiber – Carbon. The handle's surface is matted (additionally sanded), which improves the Technician's grip. Its 435 mm length and proper balancing at a total weight of 210 g allows for precise and efficient work.



• NTS MDW

Ball-peen hammer (PTFE-rubber)

A precise, small bodywork repair hammer with two round hammerheads with a spherically finished work surface. A hard PTFE hammerhead on one side, a rubber one on the other. Foot diameter approx. 12mm. Designed for finishing works or non-invasive repairs on the paint coat.

APP NO.	Description
360753	Handle made from solid hickory wood. The handle's non-resonating wood is particularly well suited for working with mallets when hammering hills.



• NTools PDR A8

Sharp mallet

A mallet made from a uniform material (PA) with a 12 mm diameter and length of 120 mm. Used for hammering hills created while pushing out dents.

APP NO.	Description
351877	The uniform construction and durable material ensure a long service life and work parameter stability. Sharp tipped.



• NTools PDR A9

Gentle mallet

A mallet made from a uniform material (PA) with a 12 mm diameter and length of 120 mm. Used for hammering hills created while pushing out dents.

APP NO.	Description
351878	The uniform construction and durable material ensure a long service life and work parameter stability. Gentle tipped.



• NTools PDR A10

Oval mallet

A mallet made from a uniform material (PA) with a 12 mm diameter and length of 120 mm. Used for hammering hills created while pushing out dents.

APP NO.	Description
351879	The uniform construction and durable material ensure a long service life and work parameter stability. Oval tipped.



• NTools PA9

Aluminum mallet with replaceable heads

The NTools PA9 is a mallet designed for use during paint-less bodywork repairs in the PDR system. The ergonomic shape and knurled surface improve the Technician's grip and precision.

> ADVANTAGES

- replaceable heads with an M8 thread (8 pcs.)
- light, aluminum body, 65 mm in length
- ergonomic shape
- large variety of heads
- knurled mallet body

APP NO.	Description
351864	Eight head shapes enable repair of nearly any uneven bodywork surface.



• NTools TP12

Set of Teflon PDR mallets, 12 elements

The NTools TP12 is a practical set of tools for evening out hills during paint-less dent repair. The NTools TP12 set provides a large variety of shapes, allowing to choose the appropriate head for the repaired damage type. The heads are made from impact resistant PTFE plastic.

> ADVANTAGES

- large variety of heads
- easy and quick replacement
- mounting stability
- two grip lengths

APP NO.	Description
351899	The grips (130 and 90 mm) are made from aluminum with a milled surface, improving the Technician's work comfort. The heads are mounted in the grip using the press-fit method, with a double, elastic, high durability O-ring.



3. Glue method - PULL

• NTools Puller Set Dent removal set

The NTools Puller Set is a toolkit intended for paint-less dent repair using the glue method. The set contains all the essential tools for performing paint-less dent repair using the Puller glue method: a glue gun, glue, a set of tabs, a W900 cleaner sample, three mallets and a hammer.



➤ ADVANTAGES

- set of tools for the Puller glue method
- a case for arranging and ensuring completeness of the set
- portability

APP NO.	Description
351750	The set's portability is ensured by a system case with a foam insert to arrange and secure all of the toolkit's elements.



• NTools MB400 Aluminum impact hammer puller for tabs

The NTools MB400 impact hammer puller is designed for paint-less dent repair using the glue method. The low weight of the aluminum ballast (400g) makes it light and convenient to use. The ergonomic grip allows for comfortable work during bodywork repair. Total length: 470 mm.



APP NO.	Length	Ballast weight	Col. pack.
351898	470 mm	400 g	1 pcs.



• NTools MB1000 Aluminum impact hammer puller for tabs

The NTools PDR MB1000 impact hammer puller is designed for paint-less dent repair. The device is made of steel and aluminum. The 1000g ballast weight makes it convenient to use and allows comfortable work when performing bodywork repair. The impact puller features an adapter for tabs, ensuring the device's compatibility with nearly any tab used in the PDR glue method. The ergonomic grip allows for comfortable work during bodywork repair. Total length: 470 mm.



APP NO.	Length	Ballast weight	Col. pack.
351886	470 mm	1000 g	1 pcs.



• NTools PNK

Puller for glue repairs

A puller for glue bodywork repairs is a device for non-invasively pulling out dents using tabs glued onto the paint coating. Tightening the puller's handle causes upward motion of the pin.

APP NO.	Description
351551	The pulling height can be precisely adjusted. Materials: steel and lacquered aluminum. The puller's supports are secured with micro-rubber pads.



• NTools PNKG

PNK Puller micro-rubber pads (left + right)

NTools PNKG – is a set (left + right) of micro-rubber pads. They are flat plates with an adhesive layer for fastening to the foot of an NTools PNK glue repair Puller.

APP NO.	Description
351553	The pads have a thickness of 4 mm and are very soft and flexible. They protect against leaving marks on a vehicle's bodywork when working with the puller.



• NTools M-VDP Set

4in1 suction cup set for pulling out dents with a pump

The NTools M-VDP Set is a professional set for paint-less removal of large, medium and mild dents present on vehicle bodyworks. The set features three special suction cup grips sized 75, 100 and 125 mm, and an adapter for repairs using a spotter. The suction cups are made from highly elastic rubber that allows them to adapt to nearly any surface. The mounting thread features a seal that ensures tightness of the vacuum system. The upper part of the device includes a pump for generating vacuum. This allows proper and stable attachment of the suction cups to the surface. The weight of the ballast (1,22kg) enables smooth reciprocating motion that does not require much effort on part of the Technician.

> ADVANTAGES

- quick and efficient removal of bodywork dents without damaging the paint
- high tightness of the vacuum system
- removal of dents on plastic bumpers
- removal of large, medium and mild dents in vehicle bodyworks
- does not require high effort from the operator
- set portability and a sturdy case
- does not require additional tools

APP NO.	Description
351760	The NTools M-VDP set is a non-invasive and effective way of repairing bodywork dents on elements such as: doors, roof, engine cover, side panels, fenders, as well as lacquered plastic bumpers.





• NTools V75/125

Set of 75mm and 125mm dent pulling suction cups

NTools V75/125 is a set of specialized tools used in paint-less bodywork dent repair. The suction cups are made from a high quality plastic and elastic rubber that allows their adjustment to nearly any surface. The 75 and 125 mm diameter suction cups allow the removal of small, medium and large dents from vehicle bodies.

➤ ADVANTAGES

- quick and efficient removal of bodywork dents without damaging the paint
- the 75 and 125mm suction cup diameters enable repair of smaller, medium and large dents on the bodywork
- ergonomic handle and rubberized elements
- high quality, elastic rubber
- suction cup protection cover

APP NO.	Description
351679	The NTools V75/125 set is a non-invasive and effective way of repairing bodywork dents on elements such as: doors, roof, side panels, engine cover, fenders, as well as lacquered plastic bumpers.



• NTools V75

75mm dent pulling suction cup

NTools V75 is a specialized tool used in paint-less bodywork dent repair. The suction cup features a 75 mm diameter rubber attachment that allows repair of smaller dents. The suction cup is made from a high quality plastic and rubber. The elastic attachment allows adjustment to nearly any surface. The upper section of the handle features a valve that releases the suction cup from the repaired bodywork element. A fitted cover protects the rubber attachment against dirt.

➤ ADVANTAGES

- quick and efficient removal of bodywork dents without damaging the paint
- the 75 mm suction cup diameter enables repair of smaller dents
- ergonomic handle
- high quality, elastic rubber
- low weight: 200 g
- suction cup protection cover

APP NO.	Description
351681	NTools V75 is a tool dedicated for work with non-reinforced bodywork elements such as: doors, roof, engine cover, side panels of delivery vehicles, etc.



• NTools V125

125mm dent pulling suction cup

NTools V125 is a specialized tool used in paint-less bodywork dent repair. The suction cup features a 125 mm diameter rubber attachment that allows repair of larger dents. The pump located in the upper part of the handle enables stable attachment to the repaired surface. The specially constructed handle provides control over pulling the dented bodywork fragment. The suction cup is made from high quality plastic and rubber. A fitted cover protects the rubber attachment against dirt.

➤ ADVANTAGES

- quick and efficient removal of bodywork dents without damaging the paint
- pump enabling stable suction cup fastening to the surface
- the 125 mm suction cup diameter enables repair of large dents
- rubber handle with additional grip
- high quality, elastic rubber
- low weight: 420g
- suction cup protection cover

APP NO.	Description
351680	NTools V125 is a tool dedicated for work with non-reinforced bodywork elements such as: doors, roof, engine cover, side panels of delivery vehicles, etc.



• NTools TAB SET

Set of dent pulling tabs

A set of tabs designed for pulling out dents in the glue method using a Puller or impact hammer pullers. The tabs are made from a plastic composite, which improves their durability.

APP NO.	Description
351710	The set features flat round, spherical and elliptical, and rectangular tabs.



• NTools TAB 13

d11 spherical round tab, red

The NTools TAB 13 is a round, spherical tab made from a durable plastic, with a diameter of 11 mm. The slightly convex structure of the NTools TAB 13 results in an even distribution of forces on the repaired surface while pulling out the dent.

APP NO.	Description
351708	The tab's small diameter enables very precise finishing of the repaired bodywork surface.



• NTools TAB 5

d16 spherical round tab, red

The NTools TAB 5 is a round, spherical tab made from a durable plastic, with a diameter of 16 mm.

APP NO.	Description
351700	The slightly convex structure of the NTools TAB 5 results in an even distribution of forces on the repaired surface while pulling out the dent.



• NTools TAB 9

d21 spherical round tab, red

The NTools TAB 9 is a round, spherical tab made from a durable plastic, with a diameter of 21 mm.

APP NO.	Description
351701	The slightly convex structure of the NTools TAB 9 results in an even distribution of forces on the repaired surface while pulling out the dent.



• NTools TAB 6

d32 spherical round tab, red

The NTools TAB 6 is a round, spherical tab made from a durable plastic, with a diameter of 32 mm. The slightly convex structure of the NTools TAB 6 results in an even distribution of forces on the repaired surface while pulling out the dent.

APP NO.	Description
351702	The tab's large diameter enables very strong pulling of the repaired bodywork surface.



- **NTools TAB 7**
d36mm green, round, flat tab

APP NO.	Packaging	Size	Col. pack.
351703	-	d36 mm	1 pcs.



- **NTools TAB 10**
d40 mm yellow, round, flat, rigid tab

APP NO.	Packaging	Size	Col. pack.
351704	-	d40 mm	1 pcs.



- **NTools TAB 11**
33 x 47 mm yellow, elliptical, flat, rigid tab

APP NO.	Packaging	Size	Col. pack.
351705	-	33 x 47 mm	1 pcs.



- **NTools TAB 12**
d40 mm purple, round, flat, elastic tab

APP NO.	Packaging	Size	Col. pack.
351706	-	d40 mm	1 pcs.

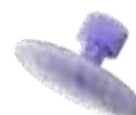

- **NTools TAB 8**
Purple, elliptical, flat, elastic tab

APP NO.	Packaging	Size	Col. pack.
351707	-	33 x 47mm	1 pcs.



- **NTools TAB 1**
d18 mm blue, round, flat, very rigid tab

APP NO.	Packaging	Size	Col. pack.
351691	-	d18 mm	1 pcs.



- **NTools TAB 2**
d18 mm blue, round, spherical, very rigid tab - convex

APP NO.	Packaging	Size	Col. pack.
351692	-	d18 mm	1 pcs.



- **NTools TAB 3**
d12 mm blue, round, flat, very rigid tab

APP NO.	Packaging	Size	Col. pack.
351693	-	d12 mm	1 pcs.



- **NTools GG 150W**

Applicator gun for hot-melt glue cartridges, with temperature adjustment

The NTools GG 150W is an electric glue gun for working with hot-melt glue in the form of cartridges. The device features temperature adjustment which expands its scope of application and allows to work with adhesives with different melting temperatures. The brass nozzle ensures precise glue dosing and long-term exploitation of the device, and air intakes protect the tool against overheating.

APP NO.	Description
351868	The NTools GG 150W is dedicated for use during paint-less dent repair using the glue method (Glue Puller) and for work performed at workshops providing various types of services.



- **NTools G STICKS BLACK**

Universal hot-melt glue

The NTools G STICKS BLACK is a universal hot-melt glue in cartridges, intended for use in paint-less glue puller dent removal techniques. The NTools G-STICK BLACK offers very high comfort of work. Its increased density allows the user easy application. The glue works well with Puller type tools during non-dynamic pulling of dents. Working temperature set on the glue gun: 125 °C (+/- 10°C). The glue can be removed from the surface using the W900 cleaner.

APP NO.	Color	Weight
351695	black	250 g
351685	black	1,0 kg

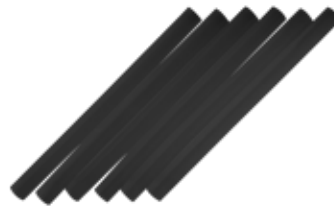

- **NTools G STICKS**

Universal hot-melt glue

The NTools G STICKS BLACK is a universal hot-melt glue in cartridges, intended for use in paint-less glue puller dent removal techniques. The NTools G-STICKS is characterized by enhanced adhesion to surfaces, which allows for stronger pulling of vehicle bodywork dents. The glue does not damage the paint, melts quickly and uniformly, and remains elastic after setting. Working temperature set on the glue gun: 135 °C (+/- 10°C). The glue can be removed from the surface using the W900 cleaner.

APP NO.	Color	Weight
351696	white	250 g

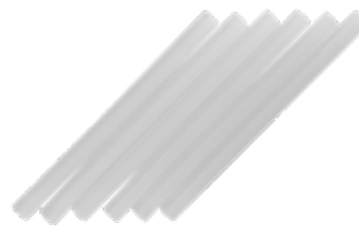

4. Glue method - PUSH

Sets of tools intended for paint-less dent repair using the push method from the convex side of the dent. They contain tools with varied head thicknesses and shapes – rounded, flat, fin-shaped, bent in a U-shape – chosen according to the shape of the dent, allowing work on all bodywork elements.

NTools nr 351805

NTools PDR Basic

Set of 8 tools.

NTools nr 351810

NTools PDR Standard

Set of 21 tools.

NTools nr 351815

NTools PDR Expert

Set of 36 tools.

- 1 351821 - BTM-70
- 2 351822 - LB-90
- 3 351823 - SWL-25
- 4 351824 - SWR-25
- 5 351825 - HK-LG
- 6 351826 - WT-10-LG
- 7 351851 - BL-30
- 8 351852 - BR-30

Basic

- 9 351850 - CD-90
- 10 351853 - BL-45
- 11 351854 - BR-45
- 12 351827 - BT-60
- 13 351828 - SWR-40
- 14 351829 - SWL-40
- 15 351830 - J-HAK
- 16 351831 - WT-30-MD
- 17 351832 - HT-10
- 18 351833 - BLT-30
- 19 351834 - W45-1-30
- 20 351835 - W45-3-30
- 21 351836 - BT-35

Standard

- 22 351837 - LB-60
- 23 351838 - SB-60
- 24 351839 - BT-90
- 25 351840 - SB-90
- 26 351841 - HK-MD
- 27 351842 - PB-60
- 28 351843 - WT-15-SM
- 29 351844 - MT-50
- 30 351845 - BBT-45
- 31 351846 - WR-1-30
- 32 351847 - WR-1-30
- 33 351848 - LB-35
- 34 351849 - CB-35
- 35 351855 - BL-60
- 36 351856 - BR-60

Expert

The NTools PDR Standard and NTools PDR Expert sets contain the PDR Basic set expanded with additional tools precisely adapted to the shape and location of damage.

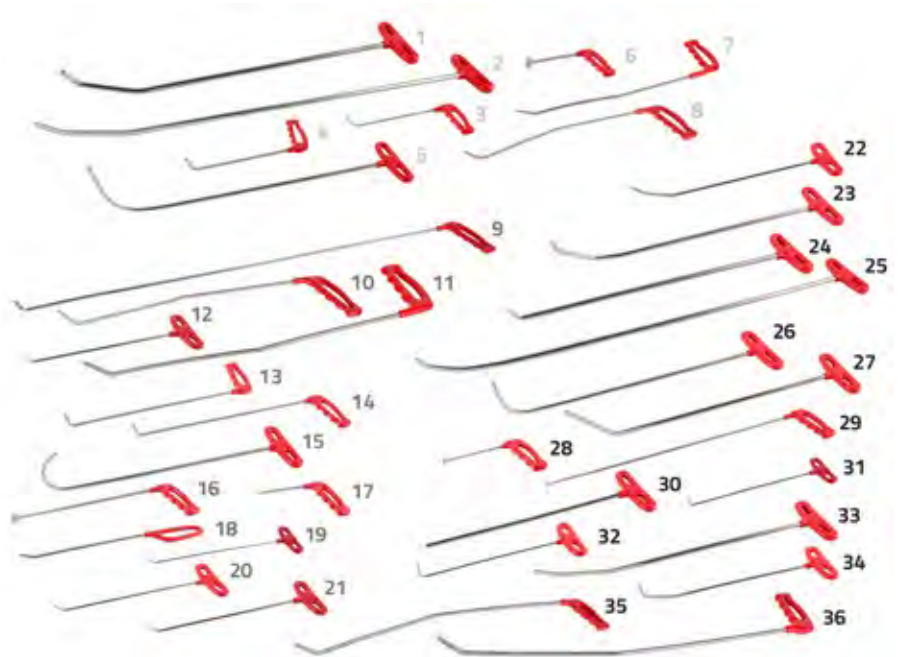

NTools PDR Expert

The increased number of tools in the set enables faster and more effective repair of dents thanks to more convenient access or gaining access to a larger area of dents present on vehicle bodyworks.

The diagram below illustrates the application locations of the NTools PDR basic dent pushing tools.

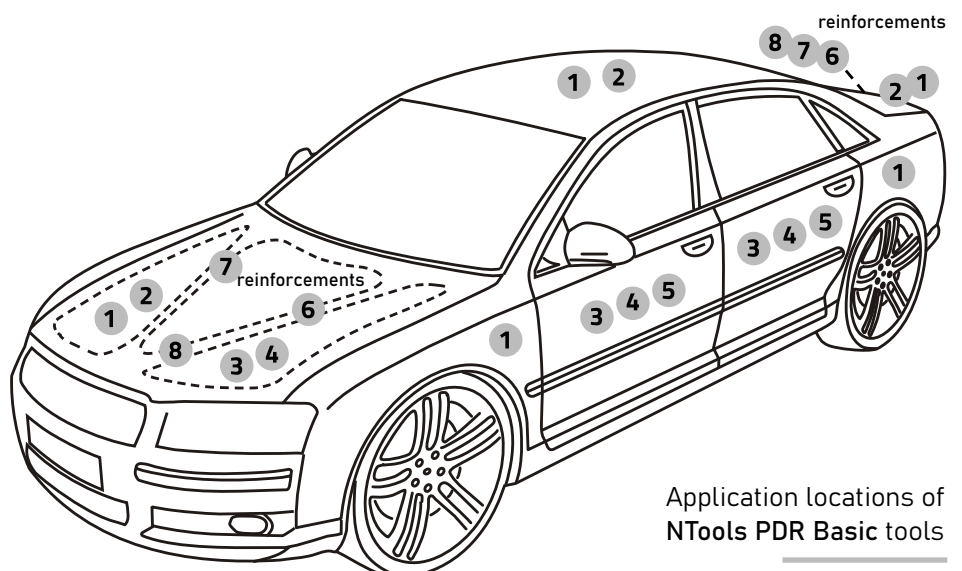

Application locations of NTools PDR Basic tools



• NTools PDR SYSTEM

Paint-less dent repair system

The NTools PDR System is a fully equipped trolley, i.e. mobile workstation, containing a complete set of all tools used for repairs using PDR technology. The trolley's tool set features tools for paint-less dent repair both on the inner side of the dent – NTools PDR EXPERT, including all accessories, as well as tools and essential accessories for performing repairs on the outer side of a dent, using the glue pull method – NTools Puller Set. The trolley also includes an NTools LC 420 lamp, a polisher, pastes, a cloth, cleaning compounds, upholstery removal tools, and other accessories.

➤ ADVANTAGES

- mobility,
- convenient work organization,
- all tools and accessories in one place,
- 5 m long power supply cable,
- easy to transport, wheel locks included

APP NO.	Description
351900	The trolley is additionally equipped with a 230V electrical installation to enable connection of electric tools, i.e. a polisher or glue cartridge gun. Also includes a hanger for the shadow lamp, polisher, and glue gun.



• NTools PDR EXPERT

Set of 36 instruments for dent removal

NTools PDR EXPERT is a set 36 tools designed for paint-less dent removal using the push method on the convex side of the dent.

APP NO.	Description
351815	The set includes tools varying in thickness and end shapes – rounded, flat, fin-shaped, bent in a U-shape – chosen according to the shape of the dent to enable work on all bodywork elements. The set contains tools from all groups – 8 planes, 10 for reinforcements, 5 fins, 4 for doors and 9 multifunctional.



• NTools PDR STANDARD

Set of 21 instruments for dent removal

NTools PDR STANDARD is a set 21 tools designed for paint-less dent removal using the push method on the convex side of the dent.

APP NO.	Description
351810	The set includes tools varying in thickness and end shapes – rounded, flat, fin-shaped, bent in a U-shape – chosen according to the shape of the dent to enable work on all bodywork elements. The set contains tools from all groups – 3 planes, 8 for reinforcements, 3 fin-shaped, 2 for doors and 6 multifunctional.

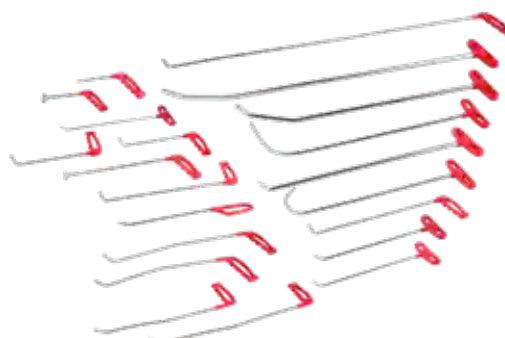

• NTools PDR BASIC

Set of 8 instruments for dent removal

NTools PDR BASIC is a set 8 tools designed for paint-less dent removal using the push method on the convex side of the dent.

APP NO.	Packaging
351805	The set includes tools varying in thickness and end shapes - rounded, flat, fin-shaped, bent in a U-shape - chosen according to the shape of the dent to enable work on all bodywork elements. The set contains tools from all groups - 2 planes, 4 for reinforcements, 1 fin-shaped, 1 for doors.

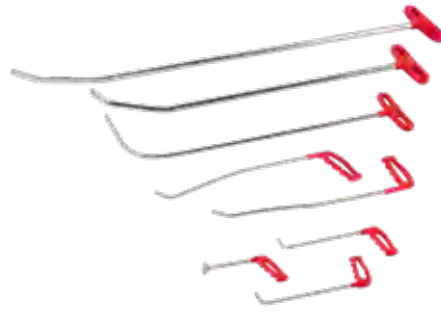

Planes

• NTools BTM 70

Dent pushing instrument.

2x bent, rounded tip (oval)

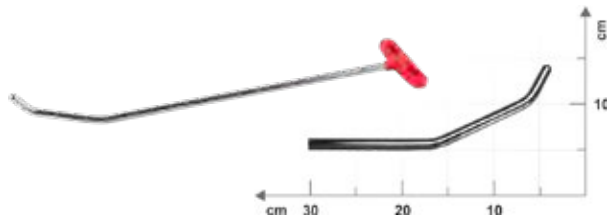

Included in the set:

NTools PDR Basic
NTools PDR Standard
NTools PDR Expert



APP NO.	Length	Thickness
351821	70 cm	12,5 mm

• NTools LB 90

Dent pushing instrument.

2x bent, flat tip

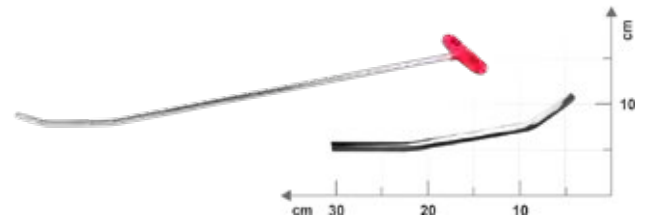

Included in the set:

NTools PDR Basic
NTools PDR Standard
NTools PDR Expert



APP NO.	Length	Thickness
351822	90 cm	11 mm

• NTools BT 60

Dent pushing instrument.

1x bent, rounded and sharpened tip

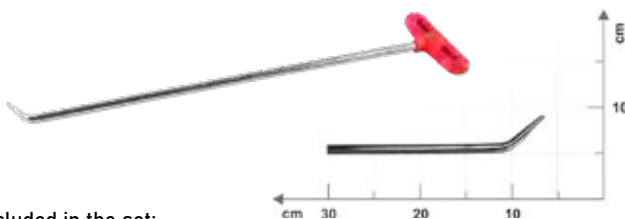

Included in the set:

NTools PDR Standard
NTools PDR Expert



APP NO.	Length	Thickness
351827	60 cm	11 mm

• NTools LB 60

Dent pushing instrument.

2x bent, flat tip

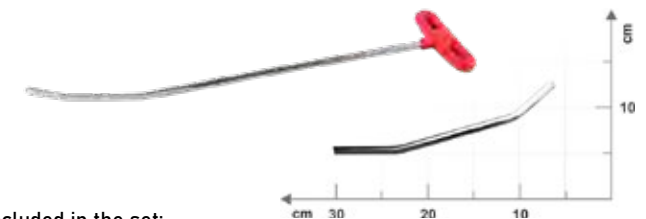

Included in the set:

NTools PDR Expert



APP NO.	Length	Thickness
351837	60 cm	9,5 mm

• **NTools SB 60**

Dent pushing instrument.

3x bent, flat sharpened tip

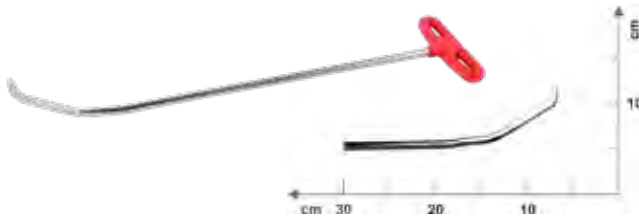

Included in the set:



NTools PDR Expert

APP NO.	Length	Thickness
351838	60 cm	9,5 mm

• **NTools BT 90**

Dent pushing instrument.

1x bent, rounded sharpened tip

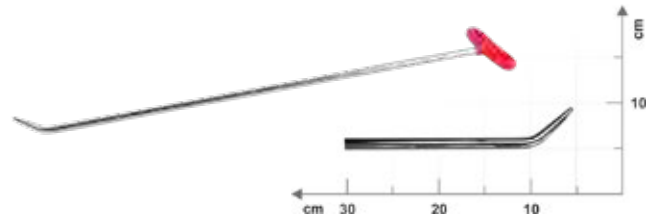

Included in the set:



NTools PDR Expert

APP NO.	Length	Thickness
351839	90 cm	12,5 mm

• **NTools SB 90**

Dent pushing instrument.

3x bent, flat sharpened tip



Included in the set:



NTools PDR Expert

APP NO.	Length	Thickness
351840	90 cm	12,5 mm

• **NTools BBT 45**

Dent pushing instrument.

straight instrument, rounded tip

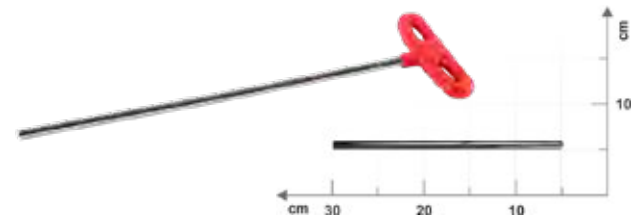

Included in the set:



NTools PDR Expert

APP NO.	Length	Thickness
351845	45 cm	9 mm

For reinforcements

• **NTools BL 30**

Dent pushing instrument.

2x bent with axial displacement, left, flat tip

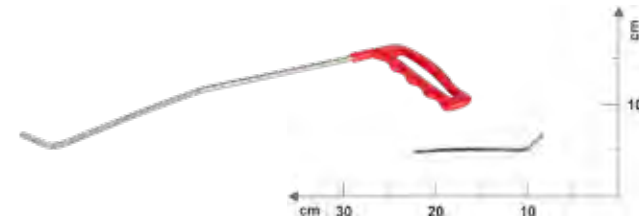

Included in the set:

NTools PDR Basic

NTools PDR Standard

NTools PDR Expert



APP NO.	Length	Thickness
351851	30 cm	4 mm

• **NTools BR 30**

Dent pushing instrument.

2x bent with axial displacement, right, flat tip

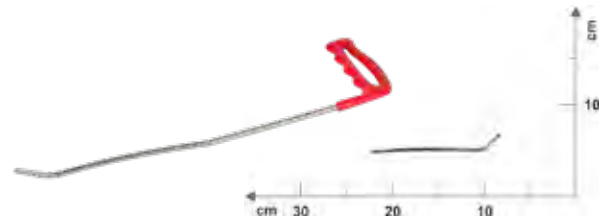

Included in the set:

NTools PDR Basic

NTools PDR Standard

NTools PDR Expert



APP NO.	Length	Thickness
351852	30 cm	4 mm

• NTools BL 45

Dent pushing instrument.

2x bent with axial displacement, left, flat tip

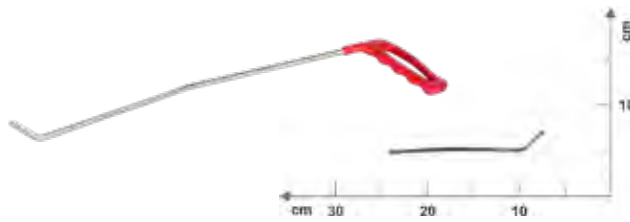

Included in the set:

NTools PDR Standard
NTools PDR Expert



APP NO.	Length	Thickness
351853	45 cm	5 mm

• NTools BR 45

Dent pushing instrument.

2x bent with axial displacement, right, flat tip

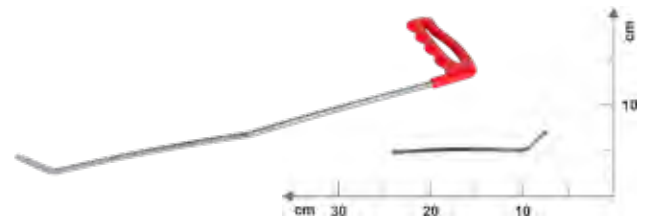

Included in the set:

NTools PDR Standard
NTools PDR Expert



APP NO.	Length	Thickness
351854	45 cm	5 mm

• NTools BL 60

Dent pushing instrument.

2x bent with axial displacement, left, flat tip

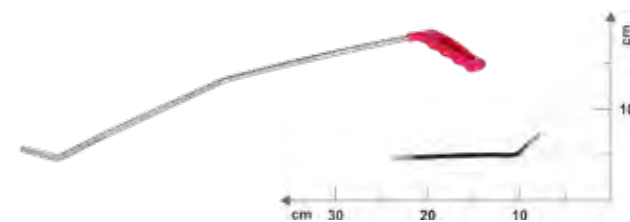

Included in the set:

NTools PDR Expert



APP NO.	Length	Thickness
351855	60 cm	7 mm

• NTools BR 60

Dent pushing instrument.

2x bent with axial displacement, right, flat tip

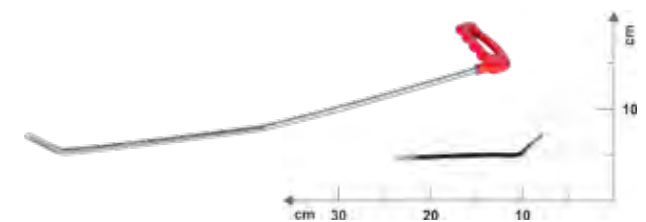

Included in the set:

NTools PDR Expert



APP NO.	Length	Thickness
351856	60 cm	7 mm

• NTools SWL 25

Dent pushing instrument.

1x bent, asymmetrical left, flat tip



Included in the set:

NTools PDR Basic
NTools PDR Standard
NTools PDR Expert



APP NO.	Length	Thickness
351823	25 cm	6 mm

• NTools SWR 25

Dent pushing instrument.

1x bent, asymmetrical right, flat tip

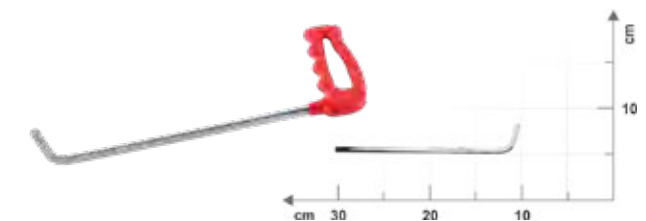

Included in the set:

NTools PDR Basic
NTools PDR Standard
NTools PDR Expert



APP NO.	Length	Thickness
351824	25 cm	6 mm

- **NTools SWR 40**
Dent pushing instrument.
1x bent, asymmetrical right, flat tip

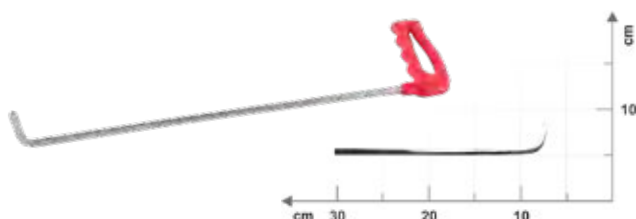

Included in the set:

NTools PDR Standard
NTools PDR Expert



APP NO.	Length	Thickness
351828	40 cm	6 mm

- **NTools SWL 40**
Dent pushing instrument.
1x bent, asymmetrical left, flat tip



Included in the set:

NTools PDR Standard
NTools PDR Expert



APP NO.	Length	Thickness
351829	40 cm	6 mm

Fin-shaped

- **NTools WT 10 LG**
Dent pushing instrument.
fin-shaped tip, large sized



Included in the set:

NTools PDR Basic
NTools PDR Standard
NTools PDR Expert



APP NO.	Length	Gubość
351826	10 cm	9 x 3 mm

- **NTools WT 30 MD**
Dent pushing instrument.
fin-shaped tip, medium sized

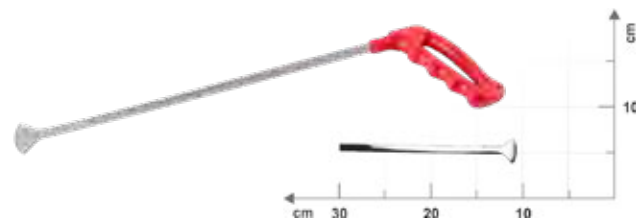

Included in the set:

NTools PDR Standard
NTools PDR Expert



APP NO.	Length	Thickness
351831	30 cm	8 x 3 mm

- **NTools HT 10**
Dent pushing instrument.
flat tip



Included in the set:

NTools PDR Standard
NTools PDR Expert



APP NO.	Length	Thickness	Col. pack.
351832	10 cm	6 mm	1 pcs.

- **NTools WT 15 SM**
Dent pushing instrument.
fin-shaped tip, small sized



Included in the set:

NTools PDR Expert



APP NO.	Length	Thickness	Col. pack.
351843	15 cm	6 x 2 mm	1 pcs.

- **NTools MT 50**

Dent pushing instrument.

fin-shaped tip, medium sized

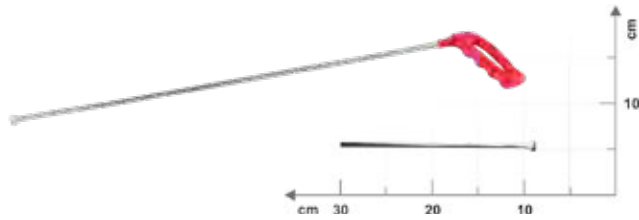

Included in the set:

NTools PDR Expert



APP NO.	Length	Thickness
351844	50 cm	5 x 3 mm

For doors

- **NTools HK LG**

Dent pushing instrument.

1x bent 90°, large arch, flat tip

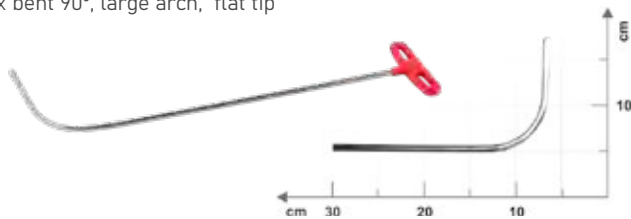

Included in the set:

- NTools PDR Basic
- NTools PDR Standard
- NTools PDR Expert



APP NO.	Length	Thickness
351825	60 cm	8 mm

- **NTools HK MD**

Dent pushing instrument.

1x bent 90°, medium arch, flat tip



Included in the set:

NTools PDR Expert



APP NO.	Length	Thickness
351841	55 cm	8 mm

- **NTools J HAK**

Dent pushing instrument.

1x bent in a U-shape, small arch, flat tip

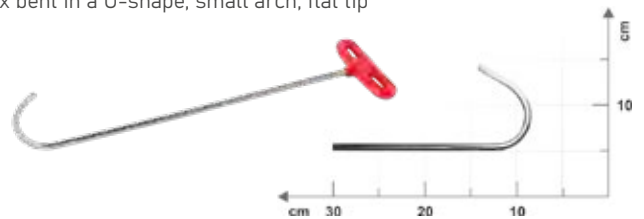

Included in the set:

- NTools PDR Standard
- NTools PDR Expert



APP NO.	Length	Thickness
351830	50 cm	8 mm

- **NTools PB 60**

Dent pushing instrument.

1x bent 60°, large arch, flat tip

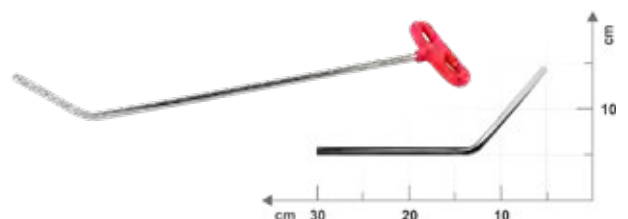

Included in the set:

NTools PDR Expert



APP NO.	Length	Thickness
351842	60 cm	9,5 mm

Multifunctional

• NTools BLT 30

Dent pushing instrument.

1x bent, rounded tip - oval

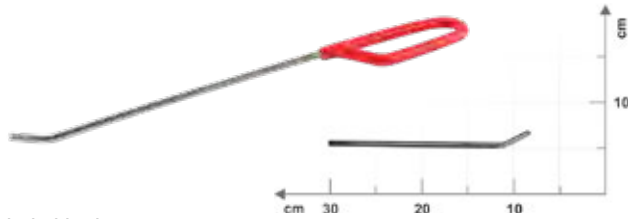

Included in the set:

NTools PDR Standard

NTools PDR Expert



APP NO.	Length	Thickness
351833	30 cm	6 mm

• NTools W45 1 30

Dent pushing instrument.

1x bent, flat tip

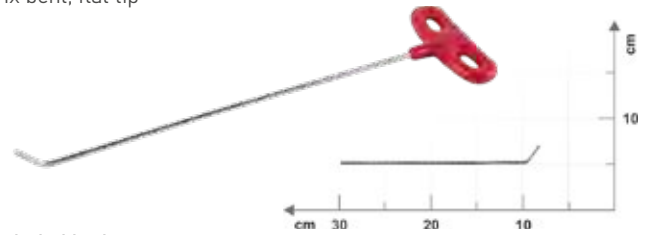

Included in the set:

NTools PDR Standard

NTools PDR Expert



APP NO.	Length	Thickness
351834	30 cm	3 mm

• NTools W45 3 30

Dent pushing instrument.

1x bent, flat tip

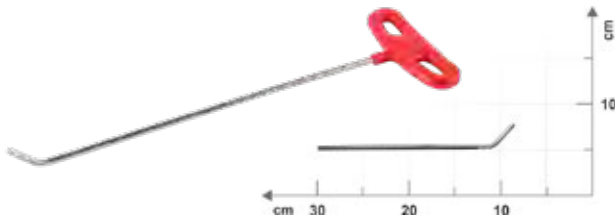

Included in the set:

NTools PDR Standard

NTools PDR Expert



APP NO.	Length	Thickness
351835	30 cm	5 mm

• NTools BT 35

Dent pushing instrument.

1x bent, flat sharpened tip

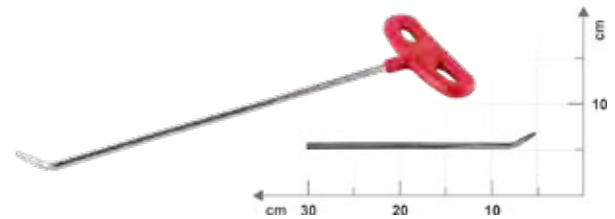

Included in the set:

NTools PDR Standard

NTools PDR Expert



APP NO.	Length	Thickness
351836	35 cm	6 mm

• NTools WR 1 30

Dent pushing instrument.

1x bent, flat tip

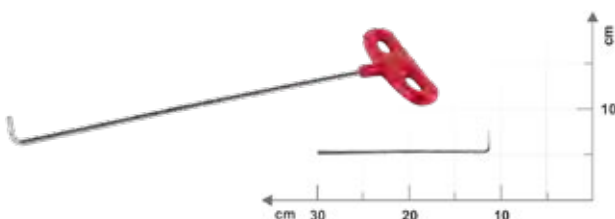

Included in the set:

NTools PDR Expert



APP NO.	Length	Thickness
351846	30 cm	3 mm

• NTools WR 3 30

Dent pushing instrument.

1x bent, flat tip

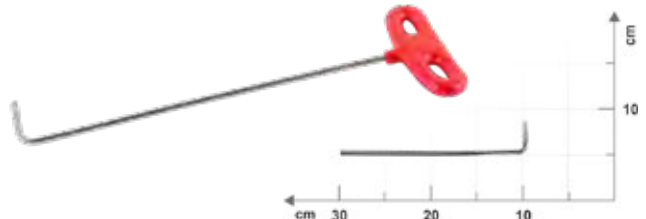

Included in the set:

NTools PDR Expert



APP NO.	Length	Thickness
351847	30 cm	3 mm

- **NTools LB 35**

Dent pushing instrument.

2x bent, flat tip

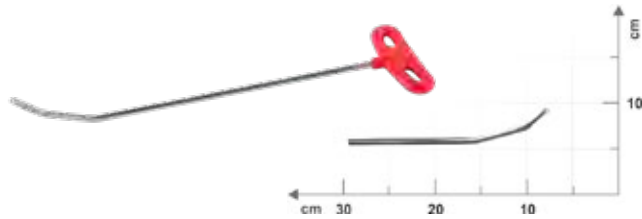

Included in the set:



NTools PDR Expert

APP NO.	Length	Thickness
351848	35 cm	6 mm

- **NTools CB 35**

Dent pushing instrument.

2x bent, flat tip

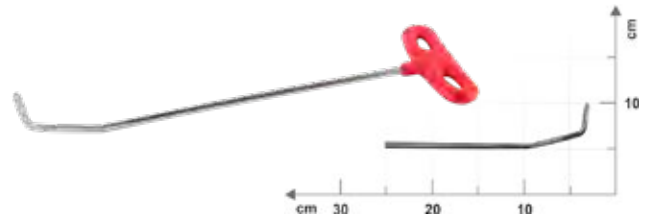

Included in the set:



NTools PDR Expert

APP NO.	Length	Thickness
351849	35 cm	6 mm

- **NTools CD 90**

Dent pushing instrument.

1x bent, flat tip

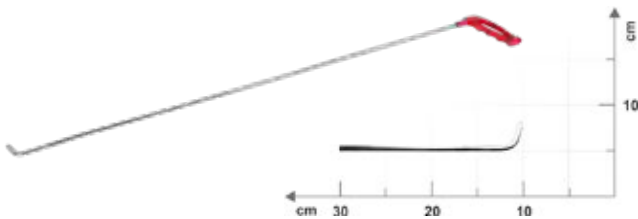

Included in the set:



NTools PDR Standard
NTools PDR Expert

APP NO.	Length	Thickness
351850	90 cm	3 mm

- **NTools PDR A1**

Hook with chain

PDR A1 – a sling for creating leverage when working with pushing instruments in the plane group.

APP NO.	Description
351870	PDR A1 – a sling for creating leverage when working with pushing instruments in the plane group.



- **NTools PDR A2**

Car cover support

The NTools PDR A2 car cover support allows to hold the car's trunk lid or engine hood in place. The support is made from steel and features rubber tips protecting the surfaces against scratching and stabilizing the support.

APP NO.	Adjustable length	Tube diameter	Rubber tip diameter
351871	38 - 60,5 cm	25 mm	40 mm



- **NTools PDR A3**
Car cover fastening strap

APP NO.	Description
351872	PDR A3 - a strap with a pulley allowing to stabilize the fastening of an element.



- **NTools PDR A4**
Hanger for work on the car roof

PDR A4 - a sling for performing works on a car roof - it allows to create leverage when working with dent pushing instruments in the plane group. It latches between the door frame and roof frame.

APP NO.	Description
351873	The pin allows to adjust the length of the tool to the height of the door frame.



- **NTools PDR A6**
Plastic door window cover

PDR A6 - a plastic cover for placing on the tempered door glass - it protects the glass against scratching during work with dent pushing instruments.

APP NO.	Description
351875	The cover is lined on one side with a velour fabric which additionally protects the window against scratching while sliding the cover onto the work area.



- **NTools PDR A7**
Wedge for deflecting the door paneling

APP NO.	Description
351876	PDR A7 - a plastic wedge for deflecting the car door paneling in order to allow insertion of tools between the window glass and the outer door panels.



- **NTools Glue Cutter**
Reinforcement cutting knife

The NTools Glue Cutter is a sharp, high quality steel knife with serrated edges. The two-sided blade with gentle, wavy or densely packed teeth is used depending on the hardness of the cut bonding mass, and ensures quick cutting of reinforcements. The knife features a very flexible, 27 centimeter long blade and an ergonomic handle facilitating a secure grip.

APP NO.	Description
351867	The sharpened tip of the blade allows to puncture soft and hard adhesives used in the automotive industry. A chrome-plated finish guarantees the steel's resistance to corrosion, abrasion and oxidation.



- **NTools PDR A15**
Ring with S type links

A ring with two S type links designed for attaching under the engine cover in order to allow work during paint-less dent pushing repairs.

APP NO.	Description
351884	The smaller link is 5 mm thick, while the ring and larger link are 6 mm. The inner diameter of the ring is 45 mm. The entire accessory is made from zinc coated steel.



• NTools UPW

Suction grip with a hanger for work on vehicle bodywork

NTools UPW – a 120 mm diameter suction cup with an adjustable length hanger.

APP NO.	Description
351897	It allows to create leverage while working with dent pushing instruments from the plane group wherever classic slings cannot be used (frame-less doors, no technological openings in element reinforcements, near an element's edge)



• NTools PDR Check Panel

Linear reflexive panel, d800

The NTools PDR Check Panel is a practical, light, foldable reflexive panel designed to reveal damage on the car bodywork. Its light construction, practical circular shape with an 800 mm diameter, comfortable handle, easy unfolding and folding, allow to quickly and efficiently conduct vehicle bodywork inspection in order to reveal surface deformations.

APP NO.	Description
351869	The black, parallel, symmetrically placed lines printed on white canvas make it easy to quickly locate any bodywork damage. The accessory facilitates photographic damage documentation. The NTools PDR Check Panel is an essential tool for PDR Technicians, appraisers, insurance claims agents.



• APP Carbon

Abrasive block

A pressed abrasive material for finish grinding in preparation for polishing. Intended for removal of inclusions, tears, and unevenness on hardened lacquered surfaces and in paint-less dent removal (PDR) techniques. For use on all types of hardened top coat lacquers.

APP NO.	Color	Type
06CAR0800	grey	P0800
06CAR1000	dark grey	P1000
06CAR1500	yellow	P1500
06CAR2000	green	P2000
06CAR3000	brown	P3000

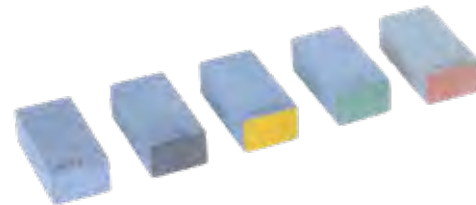

• NTools URS12

Set of 12 element disassembly tools

URS12 is a set of 12 specialized tools useful during disassembly of: upholstery, moldings, clips and studs in motor vehicles. The specially molded shapes of the tools allows quick disassembly of upholstery elements in the interior of any vehicle.

APP NO.	Description
251315	The tools are made from hardened nylon, which increases their hardness and, in particular, durability when using leverage during removal of upholstery clips.



• NTools A14

Dent pushing instrument storage bag

APP NO.	Description
351883	A14 - A practical and durable tool bag for storing and transporting dent pushing instruments. Closed with a zipper running along the bag's entire length.



• NTools PDR RACK

Mobile repair rack

The NTools PDR RACK is a mobile rack designed for use during paint-less removal of dents on bodywork elements. It enables mounting of elements disassembled from the vehicle, such as engine and trunk covers, fenders or doors.

> ADVANTAGES

- mobile
- large, rubberized pivoting wheels with brakes
- wide range of applications
- convenient to transport
- takes up little space when collapsed
- unhindered maneuvering
- zinc coating on the entire structure

APP NO.	Description
170507	The NTools PDR RACK is equipped with a set of S-shaped supports that allow to mount any bodywork element. The adjustable height and arm spacing of the mobile rack make it possible to adapt the element's position according to the Technician's preferences. The set includes 4 units of NTools PDR A3 - straps with pulleys for stabilizing the mounted element.



• NTools PDR Tool Cart

Mobile tool cart

The NTools PDR Tool Cart is a mobile workstation designed for people handling PDR works. A light, collapsible tool cart with height adjustment.

> ADVANTAGES

- mobile
- height adjustment
- convenient to transport
- takes up little space when collapsed
- unhindered maneuvering

APP NO.	Description
170509	The cart allows to securely hang / put away tools used by the technician when conducting repairs. Mounted on 4 pivoting, rubberized wheels with a diameter of 125 mm. Each wheel is equipped with a brake.



• NTools PDR W

System trolley

The NTools PDR W is a mobile workstation designed for people performing PDR works. The trolley allows to arrange tools used by the technician during bodywork repairs using the PDR method.

> ADVANTAGES

- stable and light structure,
- mobility and work organization,
- ability to block the wheels,
- electrical installation,
- tool hanging bracket,
- system of shelves

APP NO.	Description
351893	The PDR W trolley is equipped with: <ul style="list-style-type: none"> • an electrical installation: 2 sockets and a 5 m long power cable • a system of tool and accessory shelves • wheel brakes • a system of holder brackets



BODYWORK REPAIR



Panel repair sets

305-351 BODYWORK REPAIR

305 - 306 • Panel repair sets

- 307 - 312 Spotters and accessories
- 313 - 318 Consumables for spotters: electrodes, rivets, triangles
- 319 - 320 Welding: wires, nozzles, grips
- 321 - 324 Panel repair tongs
- 325 - 328 Spreaders, pullers and clamps
- 329 - 342 Specialized body repair tools
- 343 - 348 Car body repair - non-invasive methods
- 349 - 351 Welding: OHS

• NTools CAR BODY REPAIR SYSTEM Premium

Panel repair system (aluminum and steel)

A fully equipped trolley with a set of tools for steel panel repairs and aluminum car bodies. The system located on the trolley allows you to perform all activities necessary to restore the original shape of damaged surfaces, and its most important element are the NTools SPOT 3000 and NTools ALU SPOT 3000 spotters. The set includes NTools ZPP 1224 overvoltage protection attached to the battery, protecting sensitive electronics vehicle being repaired. A panel repair could not take place without the NTools PULL SYSTEM pulling beam, Puller and counterweight with claws, which can be used to repair any place of a damaged car body. It is very important that when repairing an aluminum body, the work surface is properly warmed up, which is why the trolley has a high-power NTools electric hot air blower with temperature and amount of blown air regulation.

The set also includes a number of additional hand tools, such as: hammers, sheet metal plates, a sheet metal rule, a pneumatic grinder with the NTools Fast Lock system and a spray gun for blowing the contaminated surface.

An additional feature that distinguishes the Premium system are the battery sets of spreaders and pullers on the trolley, necessary for sheet metal repairs, and a complete system for non-invasive (adhesive) repairs, which includes a mushroom puller, mushrooms and strips for removing larger dents. The whole is completed with accessories: glue gun, hot-melt glue, mallets, etc. All elements of the set are on a trolley equipped with electrical and pneumatic installations with air purification filters. In addition, the trolley has a perforated board to which you can attach tool hangers and fully organize the workplace.



APP NO.	Description
354003	Panel repair system (aluminum and steel)

• NTools CAR BODY REPAIR SYSTEM Aluminium

System do napraw panelowych (aluminiowych)

A fully equipped trolley with a set of tools for panel repairs of aluminum car bodies. The system located on the trolley allows you to perform all activities necessary to restore the original shape of the damaged surfaces, and its most important element is the NTools ALU SPOT 3000 spotter. The set includes NTools ZPP 1224 overvoltage protection, connected to the battery, protecting the sensitive electronics of the repaired vehicle. A panel repair could not take place without the 0.9m NTools Pull System, NTools PNP SET Puller and claw counterweights, which can be used to repair any place of a damaged car body. It is very important that when repairing an aluminum body, the work surface is properly warmed up, which is why there is an electric hot air gun NTools on the trolley.

with high power with adjustable temperature and amount of blown air. The set also includes a number of additional hand tools, such as: hammers, sheet metal plates, a sheet metal rule, a pneumatic grinder with the entire NTools Fast Lock system and a gun for blowing out the contaminated surface. All elements of the set are on a trolley equipped with electrical and pneumatic installations with air purification filters. In addition, the trolley has a perforated board to which tool hangers can be mounted and fully organize the workplace.



APP NO.	Description
354002	Panel repair system (aluminum)

• NTools CAR BODY REPAIR SYSTEM Standard

Panel repair system (steel)

A fully equipped trolley with a set of tools for panel repairs of steel car bodies. The system located on the trolley allows you to perform all the activities necessary to restore the original shape of damaged surfaces, and its most important element is the NTools SPOT 3000 spotter.

The set includes an anti-overvoltage device attached to the battery, and protecting the sensitive electronics of the repaired vehicle. A panel repair could not take place without the following sets: Pulling beam PULL SYSTEM, Puller and counterweights with claws, thanks to which you can repair any place of a damaged car body. The set also includes a number of additional hand tools, such as: hammers, sheet metal picks, a tinsmith rule and a gun for blowing the contaminated surface. The trolley is equipped with electric and pneumatic installations as well as air cleaning filters. In addition, the trolley has a perforated board to which tool hangers can be attached and thus fully organized workplace.



APP NO.	Description
354001	Panel repair system (steel)

BODYWORK REPAIR



Spotters and accessories

305-351 BODYWORK REPAIR

- 305 - 306 Panel repair sets
- 307 - 312 • Spotters and accessories**
- 313 - 318 Consumables for spotters: electrodes, rivets, triangles
- 319 - 320 Welding: wires, nozzles, grips
- 321 - 324 Panel repair tongs
- 325 - 328 Spreaders, pullers and clamps
- 329 - 342 Specialized body repair tools
- 343 - 348 Car body repair - non-invasive methods
- 349 - 351 Welding: OHS

• NTools SPOT 3000D / 3000DP

Compact spotter for repairing steel panels with accessories

Spotter NTools SPOT 3000 is a basic tool necessary in every workshop. Designed to perform any work related to removing dents from car bodies. Thanks to the technology of short current pulses, it allows you to repair elements without removing the upholstery. After the modernization of NTools SPOT 3000, it is equipped with a new, more powerful transformer about 380V power supply. This ensures much more stable operation of the device and protects against sudden current drops. Spotter available in two versions of the equipment: NTools DIGI SPOT 3000 (350004D) and NTools DIGI SPOT 3000 Plus (350004DP).

> The set includes:

- 1 steel counterweight with triangle handle 1,1 kg (350004D) - APP NO. 351033 or
- 2 copper counterweight 1,1 kg (350004DP) - APP NO. 350378
- indentation electrode (bubble) - APP NO. 350236
- carbon electrode d10.4mm for the spotter (4 pcs.) - APP NO. 350238
- copper triangle for spotter 10 pcs. - APP NO. 350520

The spotter can be equipped with various types of welding electrodes washers, rivets, nails, screws, slide hammers, available in the APP offer.



APP NO. 350004D



APP NO. 350004DP



ACCESSORIES



1
NTools SPOT 3000D



2
NTools SPOT 3000DP

> TECHNICAL DATA

APP NO.	350004D / 350004DP
Voltage	400V 50Hz / 60Hz
Maximum current	3000A
Work cycle	3000A 5%
Maximum power	20 kVA
Weight	24 kg + equipment
Size	345 x 205 x 235 mm



• NTools ALU SPOT 3000

Compact spotter for repairing aluminum panels with accessories

NTools ALU SPOT 3000 has been specially designed to perform any work related to removing dents from car bodies made of aluminum, by welding rivets with a diameter from M3 to M6. The Spotter is microprocessor controlled and has a digital display. The device allows you to repair the car body without removing the upholstery.

> The set includes:

- automatic welding gun
- ground wire
- rivets M4 AlSi12 (100 pcs.)
- rivets M4 AlMg3 (100 pcs.)
- rings screwed on rivets (5 pcs.)
- electrode for welding rivets



> TECHNICAL DATA

APP NO.	352600
Voltage	230V 50/60Hz
Power range	1 - 9
Quick heating	1 ms
Heated rivets	from 3 mm to 6 mm
Weight	11 kg



SPOTER



ACCESSORIES

• Dent extraction



Damages resulting from a collision or accident most often require interference with the structure of the material. Then, the varnish coat is removed and, using specialized devices, various accessories are welded to the surface of the sheet (depending on the specifics and the place of damage), in order to later use the appropriate tools (described below) to reverse the effects of a collision or accident. This type of method is called invasive repair.



product in use:



- 01
- 02
- 03

01



Electronic compact spotter with accessories
NTools DIGI SPOT 3000 / 3000 Plus
APP NO. 350004D / 350004DP

Puller for spot repair
APP NO. 351550

02



Electronic compact spotter with accessories
NTools DIGI SPOT 3000 / 3000 Plus
APP NO. 350004D / 350004DP

Beam lining up with accessories - PULL SYSTEM
APP NO. 351497

- Elektroda
APP NO. 350245
- Eyelets simple
APP NO. 351510
- Eyelets oblique
APP NO. 351515
- Rod 300 mm
APP NO. 351521



03



Electronic compact spotter with accessories
NTools DIGI SPOT 3000 / 3000 Plus
APP NO. 350004D / 350004DP

Counterweight 0,5 kg
APP NO. 351030

Counterweight 1,8 kg
APP NO. 351036

- Copper-handle to the triangle
APP NO. 350357
- Triangle Copperweld
APP NO. 350521N



• NTools PNP SET

Puller for spot repairs with accessories

The spot repair puller is a universal device for removing small dents. It has a very wide range of adjustment of both the supports and the extraction mandrel. Thanks to this, it can work on almost any surface.

➤ The set includes::

- 1 point electrode for removing small dents - APP NO. 351555
- 2 electrode adapter 351555 - APP NO. 351558
- 3 adapter for connecting the puller to the spotter (welding machine) - APP NO. 351560
- 4 mushroom holder - APP NO. 351552

Puller can work with the spotter or with PDR adapters (mushrooms) for hot melt adhesive.

APP NO.	Product name
351550	Puller for spot repairs with accessories
351554	NTools PNP BAR - Crossbar for the puller for spot repairs 3541550 40cm



• NTools EL

Point electrode for removing small dents

Point electrode for removing small dents for puller (APP NO. 351550)

APP NO.	Description
351555	Point electrode



• NTools BW STANDARD

Beam lining up with accessories - PULL SYSTEM + Comb lining

Professional 0.9m tool for removing dents. The beam has two movable, rotating and sliding supports that allow for a stable support on each plane.

The beam is also equipped with a sliding link with a feed for precise removal of dents. The set includes a 6 claw comb. Beam and support made of aluminum, and the tendon of steel.

APP NO.	Product name	Option	Size
351497	Beam lining up - PULL SYSTEM	-	-
351063	Comb lining (6 claws)	PW-9	M14 x 1,5
351064	Comb lining (8 claws)	PW-10	M14 x 1,5
351497P	Claw for comb lining PULL SYSTEM (1 claw)	PW-1	-

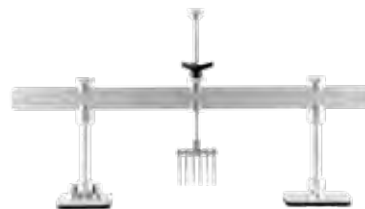

APP NO. 351497



APP NO. 351063

• NTools PW 2

Counterweight 0,5kg with a tip to handle spotter

Counterweight 0,5kg with a tip to handle spotter

APP NO.	Product name	Weight
351030	NTools PW 2	0,5 kg



• NTools PW 5

Counterweight 1,1 kg for pulling, for welding machines and spoters

Counterweight 1,1 kg for pulling, for welding machines and spoters

APP NO.	Description	Weight
350378	NTools PW 5	1,1 kg



• NTools PW 3

Counterweight with a tip to handle spotter and triangles

Puller with the possibility of direct connection to a spotter gun. Equipped with a copper triangle holder. For cooperation with 350521N copper triangle

APP NO.	Product name	Weight
351033	NTools PW 3	1,1 kg



• NTools PW 6

Spotter counterweight to handle and tip the spotter

Puller with handle, for direct assembly to welder. M14x1.5 thread enables assembly of spacer hook, nail holder or pulling bracket.

APP NO.	Product name	Weight
351036	NTools PW 6	1,8 kg



• NTools PW 7

Counterweight with handle

Puller of increased inertia force (2,5 kg). M14x1.5 threaded working part enables assembly of adapters.

Total length: 480 mm

Total mass: 3,44 kg

Pin diameter: 65 mm

APP NO.	Product name	Weight
351038	NTools PW 7	2,5 kg



• NTools MM SPOT Spotter mass - magnetic

Mass along with spot electrode and magnetic disk for sheet metal related works. Spot electrode is heated to sheet metal and magnetic disk ensure additional stability of electrode position. Only place of spot electrode require removal of top coat, whereas magnetic disk may be placed on top coat.



APP NO.	Product name
351002	Mass along with spot electrode and magnetic disk for sheet metal related works

• NTools ZPP 1224 Overvoltage Protection

Surge protector has been designed to provide protection for car electronics during welding and plasma cutting of car body sheet metal.

> ADVANTAGES

- It protects ABS, computer, alarm system and user setting memory.
- eliminates small surge
- In case of major short circuit it handles loading and at the same protects car electronics
- attached to the car battery terminals removing the need to disconnect the battery during car repairs

> TECHNICAL DATA

- triple protection
- voltage range from 12V to 24V
- correct connection LED signaling



APP NO.	Product name
353903	Surge / overvoltage protection

• NTools WZ80 / WZ120 Spotter and welding equipment trolley

The NTools WZ80 (load capacity up to 80 kg) and NTools WZ120 (load capacity up to 120 kg) are three-shelf trolleys for transporting welding equipment and spotters. They are made from 2mm thick steel sheet with a structural coating that prevents scratches. The trolleys feature space for a gas canister. The top shelf is angled in such a way that allows the device's operator access to the control panel. The bottom shelf is intended for storing all kinds of welding accessories, such as triangles, rivets, welding wires, etc.



APP NO. 350380

> FEATURES:

- load capacity: up to 80 kg (APP NO. 350380) and 120 kg (APP NO. 350381)
- 3 shelves and a 2mm thick steel sheet construction
- 3 special hangers: for the welding cable and handle and for impact hammers (counterweights)
- 4 wheels – two rear, fixed, large \varnothing 200 mm and two front, pivoting \varnothing 100 mm



APP NO. 350381

APP NO.	Product name	Load capacity	Description
350380	Trolley for spotters and welding equipment	Max 80 kg	top shelf 28 x 45 cm
350381	Trolley for spotters and welding equipment	Max 120 kg	top shelf 33 x 55 cm

BODYWORK REPAIR





Consumables for spotters:
electrodes, rivets, triangles







305-351 BODYWORK REPAIR

- 305 - 306 Panel repair sets
- 307 - 312 Spotters and accessories
- 313 - 318 • Consumables for spotters: electrodes, rivets, triangles**
- 319 - 320 Welding: wires, nozzles, grips
- 321 - 324 Panel repair tongs
- 325 - 328 Spreaders, pullers and clamps
- 329 - 342 Specialized body repair tools
- 343 - 348 Car body repair - non-invasive methods
- 349 - 351 Welding: OHS



















ELECTRODES FOR STEEL BODIES

Photo	APP NO.	Product name	Product information	QR CODE
	350247	NTools EL 10 Electrode for wavy wire	Electrode for welding the corrugated wire to the sheet surface. The electrode can be used with any spotter or welding machine with a handle with a diameter of 10mm. Used for the TECNA 7630, SPOT 3000 spotter. Adapter 350270 required.	
	350354	NTools EL 11 Counterweight head for rivets (nails)	Nail head, to be attached to any counterweight with M14x1.5 thread	
	350502	NTools EL 12 Electrode for nails 2 mm and 2.5 mm	Threaded electrode. Used with the TECNA 7630 spotter for heating purposes nails (rivets) 350515 and 350516 with a length of 50 mm. And a diameter of 2 and 2.5 mm.	
	350503	NTools EL 13 Electrode for copper plated screw	Threaded electrode. Used for TECNA 7630 spotter for welding rivets with a thread diameter of 4 mm.	
	350504	NTools EL 14 Electrode for magnet rivet	Used for the TECNA 7630 spotter for welding rivets with thread.	
	350505	NTools EL 15 Pad electrode	Used for TECNA 7630 spotter for welding 350525 washers. Adapter 350270 required.	
	350507	NTools EL 16 Bubble electrode	Used for the TECNA 7630 spotter. It is used for local heating of sheet metal in order to reduce bulges. Adapter 350270 required.	
	350235	NTools EL 1 Point electrode for spotter	Spot welding electrode one-sided. Diameter 10 mm.	
	350236	NTools EL 2 Bubble electrode for spotter	Cylindrical electrode for point bulging. It is used to dent the resulting bulges after pulling out a point. Diameter 16 mm.	
	350237	NTools EL 3 Semicircular electrode for the spotter	Electrode for weld-in of fender repair panels. May be also used for snake type wire weld-in.	
	350238	NTools EL 4 A carbon electrode to spotter	Pointy coal electrode for heating, impressing, hardening and constricting, diameter 10mm length 350mm	
	350239	NTools EL 5 Electrode for rivets for spotter	An electrode for fastening rivets, incl. side moldings. It can be used to weld rivets: 350530, 350531, 350532. For rivets 3 x 3.2; 3 x 4.5; 5 x 10 mm. Diameter 16 mm.	
	350240	NTools EL 6 Electrode rivet (nails)	Electrode for welding rivets (nails) 350515 and 350516 with a length of 50 mm and a diameter of 2 and 2.5 mm and rivets with a thread diameter of 4 mm. Electrode diameter 16 mm.	





















ELECTRODES FOR STEEL BODIES

Photo	APP NO.	Product name	Product information	QR KOD
	350241	NTools EL 7 Electrode threaded rivets to spotter	The electrode is intended for welding rivets with thread with a diameter of 5 and 6 mm. Electrode diameter 16 mm.	
	350242	NTools EL 8 Electrode for pads for spotter	Electrode with a magnet for welding the pads 350525 vertical to the surface of the sheet. Electrode diameter 16 mm.	
	350245	NTools EL 9 Mesh electrode (bits)	Electrode used for 351510 straight and slanted 351515 eye bolt weld-in.	







TRIANGLES, RIVETS, WASHERS, BITS, HOSES - STEEL BODIES

Photo	APP NO.	Product name	Product information	QR KOD
	351510 351510X	NTools OP 1/2 Eyelets (bits) simple (50 pcs. and 10 pcs.)	Eyelets with increased stiffness and thickness for pulling larger dents. Welded on in the damage line using electrode 350245. He translates through the eyelets rod 351520 or 351521 is pulled out. Withdrawal proceeds through handle 351070 or extraction comb.	
	351511 351511X	NTools OP 1/2 Eyelets (bits) simple (100 pcs. and 10 pcs.)	Welded in the damage line with electrodes 350245. He translates through the eyelets are the bar 351520 or 351521. Withdrawal occurs through handle 351070 or extraction comb.	
	351515 351515X	NTools OS 1/2 Eyelets (bits) oblique (50 pcs. and 10 pcs.)	Eyelets with increased stiffness and thickness for pulling larger dents. Welded on in the damage line using electrode 350245. He translates through the eyelets are the bar 351520 or 351521. Withdrawal occurs through handle 351070 or extraction comb.	
	351516 351516X	NTools OS 1/2 Eyelets (bits) oblique (100 pcs. and 10 pcs.)	Welded in the damage line with electrodes 350245. He translates through the eyelets rod 351520 or 351521 is pulled out. Withdrawal proceeds through handle 351070 or extraction comb.	
	351520	NTools PR 0 Rod length: 180 mm	Used for repairs with the use of welded in the line of the eyelets' damage. The rod slides into the eyelets and through the pulling force is transmitted to it.	
	351521	NTools PR 0 Rod length: 300 mm	Used for repairs with the use of welded in the line of the eyelets' damage. The rod slides into the eyelets and through the pulling force is transmitted to it.	
	350357	NTools EL 17 Copper-handle to the triangle	To be attached to any counterweight with M14x1.5 thread. UWeight! The counterweight must be able to be connected directly to the spotter or welding machine.	
	350521N	NTools TMS SPOT Triangle Copperweld to spotter Pack 10 pcs.	Mounted on a counterweight connected directly to the spotter. Heated to the surface of the sheet at the point of damage. The copper triangle works with the NTools DIGI SPOT 3000 spotter and NTools DIGI SPOT 3000 Plus. Designed to be mounted on a counterweight connected to the spotter, equipped with a special triangle holder.	
	350508	NTools HP SPOT Hook for washers	A hook used to remove dents using washers. The hook is placed in the counterweight head intended for rivets (nails) 350354.	

TRIANGLES, RIVETS, WASHERS, BITS, HOSES - STEEL BODIES

Photo	APP NO.	Product name	Product information	QR KOD
	351070	NTools ADW 1 Adapter for pulling dents by a rod	Adapter attached to Pin of Extruder Beam 351497 or Puller 351550.	
	350525	NTools PM SPOT Copper pad to spotter (100 pcs.)	Washer welded to the surface of the sheet in place damage with electrode 350242 or 350505.	
	350515	NTools NM SPOT The copper rivet to spotter 2x50 mm (100 pcs.)	The rivets are heated to the sheet surface with an electrode 350240 or 350502 at the dent. Extraction is performed using the 350354 head and counterweight.	
	350516	NTools NM SPOT The copper rivet to spotter 2,5x50 mm (100 pcs.)	The rivets are heated to the sheet surface with an electrode 350240 or 350502 at the dent. Extraction is performed using the 350354 head and counterweight.	
	350530	NTools NMG SPOT The copper rivet to spotter 3x3,2 mm (100 pcs.)	Rivet for welding to the surface of the sheet. Mainly used as a lath fixation on vehicle bodies.	
	350531	NTools NMG SPOT The copper rivet to spotter 3x4,5 mm (100 pcs.)	Rivet for welding to the surface of the sheet. Mainly used as a lath fixation on vehicle bodies.	
	350532	NTools NMG SPOT The copper rivet to spotter 5x10 mm (100 pcs.)	Rivet for welding to the surface of the sheet. Mainly used as a lath fixation on vehicle bodies.	
	350534	NTools NMW SPOT The copper rivet threaded to spotter 5,5x12 mm. (100 pcs.) 5 x 12 m	Heated with an electrode 350241 or 350504. The most frequently used for attaching the hooks of electric bundles.	
	350535	NTools NMW SPOT The copper rivet threaded to spotter 5,5 x 25 mm. (100 pcs.) 5 x 25 m	Heated with an electrode 350241 or 350504. The most frequently used for attaching the hooks of electric bundles.	
	350527	Wavy wire lenght: 300 mm. (10 pcs.)	Corrugated wire for welding with electrodes 350247. Removal of dents using an extraction comb.	

CONSUMABLES FOR SPOTTERS - ALUMINUM BODIES

Photo	APP NO.	Product name	Product information	QR KOD
	350538	NTools NA 1 Aluminum sheet rivet, M4 x 16 mm, pack. (100 pcs.)	Welded with a spotter to 352600 aluminum. Used to remove dents in cars, in which the body is made of aluminum sheet.	
	350537	NTools ONA 1 Ring screwed on rivets for aluminum sheet, M4, pack. (5 pcs.).	The ring is screwed on with rivets to the 350538 aluminum sheet. Used to remove dents in cars, in which the body is made of aluminum sheets.	
	350539	NTools NA 2 Aluminum sheet rivet, M4 x 16 mm pack. (100 pcs.)	NTools NA 2 is an aluminum rivet (AlSi12) attached to the aluminum surface with a special aluminum spotter NTools ALU SPOT 3000 (No. 352600). The package contains 100 pcs. 16 mm long rivets with M4 thread. The ring NTools ONA 1 (No. 350537) is screwed onto the rivet.	

• EXAMPLES OF REPAIRS:

01



- > Substrate preparation and welding the eyelets in the damage line

After removing the main dent, the beam is disassembled and the remaining eyelets are tightened. For final surface leveling Puller is used.

02



03

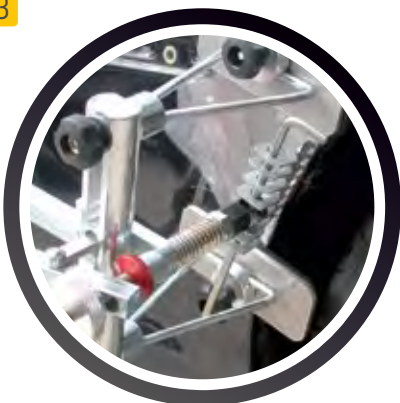

- > Puller lever 351550 can also be used as short extraction beam after application adapter 351568.

BODYWORK REPAIR



Welding: wires,
nozzles, grips

305-351 BODYWORK REPAIR

- 305 - 306 Panel repair sets
- 307 - 312 Spotters and accessories
- 313 - 318 Consumables for spotters: electrodes, rivets, triangles
- 319 - 320 • Welding: wires, nozzles, grips**
- 321 - 324 Panel repair tongs
- 325 - 328 Spreaders, pullers and clamps
- 329 - 342 Specialized body repair tools
- 343 - 348 Car body repair - non-invasive methods
- 349 - 351 Welding: OHS

• APP DS MIG

Welding wire Cu-Si 3%

Wire for brazing galvanized sheets and sheets of increased strength (HSS, UHSS, Boron), copper and copper-silicon alloys. The special composition and lower welding temperature help to avoid damage to the zinc layer and changes in the structure of the material. Calibrated wire, precisely wound. Diameter 0.8 mm 2 kg and 5 kg spool, diameter 200 mm APPLICATION: - used in the automotive industry - in the construction of ventilation devices and containers. Welding wire in semi-automatic MIG / MAG machines equipped with a braze welding program. Welding is carried out in the shield of Argon (I1) or a mixture of Argon and Helium (I3).

APP NO.	Weight	Size
350106	2 kg	0,8 mm
350107	5 kg	0,8 mm



• NTS DS ALMG

Aluminum welding wire AlMg5

Aluminium wire containing 5% magnesium (ER 5356). Provides improved resistance to cracks comparing to other contains less magnesium. For welding purposes with argone, helium or mixture Ar+He, wire dia.: 1.0mm Spool dia.: 200mm Spool weight: 2kg.

APP NO.	Weight	Size
350126	2 kg	1,0 mm



• NTools US 2

Welding holder

NTools US 2 ntop quality electrode holder cooled with shielding gas and air. Provided with elastic part connected with ball joints and EURO type push-in fitting . Features with ergonomics, and thanks to nickelplated and curved „part“ it offers cooling capacity 15% higher comparing to standard solutions. Recommended in particular for works where, other holders give up.

➤ FEATURES

- EURO type push-n fitting.
- high duty cycle 60%
- Cooled with shielding gas and air.

Model	NTools US 2
Index	350324
Torch type	MB15 (stiff)
Rated welding current – CO2	180A – 60%
Rated welding current- gas mixture Ar/CO2	150A – 60%
Grip lenght	3 m
Plug	EURO
Welding wire diameter	0,6 – 1,2 mm
Gas flow speed:	10 – 18 l/min
Cooling type:	shielding gas and air



• APP DG MB13

Conical gas nozzle MB13 standard

Conventional gas nozzle MB13 standard for APP U-SPAW welding torch.

APP NO.	Color / Option
350215	MB13



• APP DP08

Welding current nozzle 0,8mm

Current nozzle for NTools US 2 welding gun.

APP NO.	Size
350205	0,8 mm



• NTS WT 4

PTFE Insert

Teflon insert for wire of dia.0.8-1.0mm. Length 4.4m. The set includes also brass cap and rubber O-ring.

APP NO.	Length	Color	Size
353480	4,4 m	blue	0,8-1,0 mm



BODYWORK REPAIR



Panel repair tongs

305-351 BODYWORK REPAIR

- 305 - 306 Panel repair sets
- 307 - 312 Spotters and accessories
- 313 - 318 Consumables for spotters: electrodes, rivets, triangles
- 319 - 320 Welding: wires, nozzles, grips
- 321 - 324 • Panel repair tongs**
- 325 - 328 Spreaders, pullers and clamps
- 329 - 342 Specialized body repair tools
- 343 - 348 Car body repair - non-invasive methods
- 349 - 351 Welding: OHS

• NTools SB W

Axial welding plier type W

NTools SB W clamping pliers are designed for use on door openings, side panels, lap joints and folded sheets. The pliers are designed for sheet metal services, welding and industry. They are adapted to work in confined spaces, allow for a permanent clamping and precise fitting of the connected body elements during sheet metal work.

> DIMENSIONS

- Jaw width: 57 mm
- Working range adjustment: 0-17 mm
- Total length: 205 mm

> FEATURES

- Type W
- Clamping mechanism with lock
- Working range adjustment (squeeze)



APP NO.	Description
360791	Type W

• NTools SB JJ

Sheet metal pliers Type JJ

NTools SB JJ sheet metal clamping pliers are designed for joining elements with turned edges.

The pliers are designed for sheet metal services, welding and industry. They are adapted to work in confined spaces, allow for a permanent clamping and precise fitting of the connected body elements during sheet metal work.

> DIMENSIONS

- Jaw width: 45 mm
- Working range adjustment: 0-15 mm
- Total length: 235 mm

> FEATURES

- Type JJ
- Clamping mechanism with lock
- Working range adjustment (squeeze)



APP NO.	Description
360792	Type JJ

• NTools SB LL

Sheet metal pliers Type LL

NTools SB LL clamping pliers are designed for joining elements with a one-sided folded edge. After mounting on the rebate of the door opening, it allows you to close the door and adjust the elements. For use on sills, wheel arches, side panels and folded sheets. The pliers are designed for sheet metal services, welding and industry. They are adapted to work in confined spaces, allow for a permanent clamping and precise fitting of the connected body elements during sheet metal work.

> DIMENSIONS

- Jaw width: 43 mm
- Working range adjustment: 0-20 mm
- Total length: 215 mm

> FEATURES

- Type LL
- Clamping mechanism with lock
- Working range adjustment (squeeze)



APP NO.	Description
360793	Type LL

• NTools SB J Sheet metal pliers Type J

NTools SB J sheet metal clamping pliers are designed for joining elements with a one-sided curved edge.

The pliers are designed for sheet metal services, welding and industry. They are adapted to work in confined spaces, allow for a permanent clamping and precise fitting of the connected body elements during sheet metal work.

➤ DIMENSIONS

- Jaw width: 17 mm
- Working range adjustment: 0-15 mm
- Total length: 215 mm

➤ FEATURES

- Type J
- Clamping mechanism with lock
- Working range adjustment (squeeze)



APP NO.	Description
360794	Type J

• NTools SB L Sheet metal pliers Type L

NTools SB L clamping pliers to help you adjust the elements. After mounting on the rebate of the door opening, it allows you to close the door and adjust the elements. For use on door openings, wheel arches and problem areas.

The pliers are designed for sheet metal services, welding and industry. They are adapted to work in confined spaces, allow for a permanent clamping and precise fitting of the connected body elements during sheet metal work.

➤ DIMENSIONS

- Jaw width: 17 mm
- Working range adjustment: 0-20 mm
- Total length: 200 mm

➤ FEATURES

- Type L
- Clamping mechanism with lock
- Working range adjustment (squeeze)



APP NO.	Description
360795	Type L

• NTools SB T Sheet metal pliers Type T

NTools SB T sheet metal clamping pliers are designed for clamping two pieces of sheet metal of the same thickness at an angle of 90 degrees.

The pliers are designed for sheet metal services, welding and industry. They are adapted to work in confined spaces, allow for a permanent clamping and precise fitting of the connected body elements during sheet metal work.

➤ DIMENSIONS

- Jaw width: 48 mm
- Working range adjustment: 0-15 mm
- Total length: 205 mm

➤ FEATURES

- Type T
- Clamping mechanism with lock
- Working range adjustment (squeeze)



APP NO.	Description
360796	Type T

• NTools SB KPL

Set of sheet metal pliers in carrying case

The set of tinsmith pliers in the NTools SZ KPL case is designed for tinsmith services, welding and industry. They are adapted to work in confined spaces, allow for a permanent clamping and precise fitting of the connected body elements during sheet metal work.

The pliers have jaw opening adjustment and a locking mechanism that blocks their clamping on the basis of a lever with a lock. They also have a squeeze adjustment mechanism.

The pliers included in the set are made of alloyed chrome-molybdenum steel. The reinforced structure of the pliers is made of pressed sheet metal with a thickness of 3 mm - the working part and of sheet metal with a thickness of 2 mm - the body.

➤ FEATURES

- 6 different types : J, JJ, L, LL, T i W
- Clamping mechanism with lock
- Working range adjustment (squeeze) from 0 to 20 mm

➤ THE SET INCLUDES:

- APP NO. 360791 - NTools SB W - Sheet metal pliers Type W
- APP NO. 360792 - NTools SB JJ - Sheet metal pliers Type JJ
- APP NO. 360793 - NTools SB LL - Sheet metal pliers Type LL
- APP NO. 360794 - NTools SB J - Sheet metal pliers Type J
- APP NO. 360795 - NTools SB L - Sheet metal pliers Type L
- APP NO. 360796 - NTools SB T - Sheet metal pliers Type T
- carrying case



More info

APP NO.	Product name
360790	NTools SB KPL / set (6 pcs.)

• NTools LP SET

Universal crimping pliers set

The NTools LP are universal, rounded Morse type crimping pliers. They are available in APP's offer in three most popular sizes: 140mm, 180mm and 220mm. The tools are made from highly durable and mechanical damage resistant carbon steel. They are entirely coated with nickel which prevents corrosion. The NTools LP feature jaws with adjustable opening width and a clamp locking mechanism. The rounded jaw profile allows to grip details with various shapes and dimensions this is done via the adjustment screw. Such adjustment makes it possible to immobilize the gripped item. Unlocking is done by releasing the lever. The NTools LP crimping pliers find broad application in various fields. They can be, among other uses, be utilized in sheet metal and car workshops, in plumbing and everyday household use.

➤ THE SET INCLUDES:

- APP NO. 360761 NTools LP140 - Universal crimping pliers 2 pcs.
- APP NO. 360762 NTools LP180 - Universal crimping pliers 1 pcs.
- APP NO. 360763 NTools LP220 - Universal crimping pliers 2 pcs.
- APP NO. 360787 NTools SZ F - Case for crimping pliers 1 pcs.

APP NO.	Description	Size	Sales unit
360760	rounded	140 / 180 / 220 mm	pcs.



More info

BODYWORK REPAIR



Spreaders, pullers
and clamps

305-351 BODYWORK REPAIR

- 305 - 306 Panel repair sets
- 307 - 312 Spotters and accessories
- 313 - 318 Consumables for spotters: electrodes, rivets, triangles
- 319 - 320 Welding: wires, nozzles, grips
- 321 - 324 Panel repair tongs
- 325 - 328 • Spreaders, pullers and clamps**
- 329 - 342 Specialized body repair tools
- 343 - 348 Car body repair - non-invasive methods
- 349 - 351 Welding: OHS

• NTools RE 5T

Spreader-puller Battery

Battery powered spreader in an innovative solution providing both spreader and puller, as a tool indispensable at any workshop. It provides many advantages including 5t pulling force at both directions and battery that powered function that makes a tool lightweight and handy. The set includes tips and extensions with tapered thread that prevents twisting. Additionally set may include door opening interlock (361305) or rear stripe pulling interlock.

► TECHNICAL DATA:

- pulling force: 5 tons
- pushing force: 5 tons
- piston stroke: 130 mm
- battery: 14.4 V
- Weight of the device: 18kg
- Weight of accessory set: 20kg

APP NO.	Description
361300	NTools RE 5T



• NTools RE 5T SET

Accessory Kit for spreader-puller battery

A set of additional accessories for the NTools RE 5T SET battery-powered spreader-stripper, including a lock for door openings or a lock when pulling the rear belt. The cordless spreader is an innovative solution of a spreader and puller in one and a useful device in every workshop. The main advantages are the pulling force of 5 tons in both directions and the battery drive, which makes the device lightweight and handy. The set includes type bits and extensions equipped with a tapered thread to compensate for the strong twisting of parts. The set can be retrofitted with additional accessories (361305) such as a locking device for door openings, or a locking device for tensioning the rear belt, for example.

► SET INCLUDE:

- rubber foot (2 pcs.)
- three with three holes
- pendulum buckle
- fixed buckle (2 pcs.)
- extension 170 mm with 5 holes (3 pcs.)
- extension 290 mm with 9 holes (3 pcs.)
- stirrup holder (2 pcs.)
- connector for a rubber foot (2 pcs.)
- shaft and cotter pin (10 pcs.)
- „L” type pin (10 pcs.)
- splitter
- swivel base for terminals (2 pcs.)
- base for terminals (2 pcs.)
- 125 mm, 170 mm, 300 mm, 500 mm extension

► TECHNICAL DATA:

- pulling force: 5 tons
- pushing force: 5 tons
- piston stroke: 130 mm
- battery: 14.4 V
- Weight of the device: 18kg
- Weight of accessory set: 20kg



OTHER ACCESSORIES FOR ELECTRIC SPREADERS RE 5T - ASK YOUR REPRESENTATIVE

APP NO.	Description
361305	NTools RE 5T SET

• NTools ROT

Door hole expander with extension (780 - 1850 MM)

Used to spreading or maintenance of the opening. Includes extension increasing the length of the rafters. At one end single jaw, double on the second (movable).

APP NO.	Size
360701	780 - 1850 mm



• NTools ZH 4T

Hydraulic kit

4T hydraulic kit with manual pump, including extensions, tips, pliers (0,5T). The kit is delivered with the plastic case.

APP NO.	Product name
360720	NTools ZH 4T



• NTS WBW

Drift 5,4kg accessories (case 10 items)

Pinch punch 6kg along with accessories purposed for repairs of body damaged parts. The kit is delivered with the plastic case.

APP NO.	360705
Description	case 10 elements
Weight / Size	5,4kg
Sales unit	set



• NTools KB 1

The compact two-way self-locking buckle

Buckle used in cases where a bypass is needed (for example, from the front of the stringer). Can be pulled longitudinally and at a 90-degree angle. Screw with a hardness of 12.9
With rectangular, coarse thread.

OTHER PULL CLAMPS - ASK A REPRESENTATIVE

APP NO.	Product name
360730	NTools KB 1



• NTools KB 2

Buckle with movable ear

The jaw is notched on both sides with a width of 100mm. Movable eye adjusts to the direction of pull within 90 degrees. Bolt of 12.9 hardness with rectangular, coarse thread.

OTHER PULL CLAMPS - ASK A REPRESENTATIVE

APP NO.	Description
360731	load capacity 5T



• NTools KB 3

Buckle to pull small

Type narrow pull clamp. Allows attachment in hard-to-reach places. Screw with hardness of 12.9 with rectangular, coarse thread.

OTHER PULL CLAMPS - ASK A REPRESENTATIVE

APP NO.	Description
360732	load capacity 5T



BODYWORK REPAIR



Specialized
body repair tools

305-351 BODYWORK REPAIR

- 305 - 306 Panel repair sets
- 307 - 312 Spotters and accessories
- 313 - 318 Consumables for spotters: electrodes, rivets, triangles
- 319 - 320 Welding: wires, nozzles, grips
- 321 - 324 Panel repair tongs
- 325 - 328 Spreaders, pullers and clamps
- 329 - 342 • Specialized body repair tools**
- 343 - 348 Car body repair - non-invasive methods
- 349 - 351 Welding: OHS

• NTools PRD

Pneumatic reamer for spot welds with clamp

High-quality professional pneumatic spot weld reamer with clamp NTools PRD is an indispensable tool in workshops and services with a sheet metal profile, and wherever there is a need to disassemble spot-welded elements. Small dimensions and a movable buckle allow you to work in hard-to-reach places, and a very gentle start-up enables precise pre-boring. The biggest advantage is the use of a pneumatic cylinder that presses the cutter against the material. As a result, the user effortlessly removes the spot welds of the dismantled element without damaging the metal sheet on the bottom.

➤ ADVANTAGES

- Low air consumption 99.1 L/min.
- Soft start
- Movable detachable arm
- Reaming depth control, air driven pressure
- Compact and robust body

➤ PACKAGING CONTENT

- Air driven reamer for spot welds
- Cobalt-steel cutter (8 x 44 mm)
- Allen key
- Quick coupling 1/4" (outer thread.)
- Lubricating oil (30 ml)
- User Manual

Model	NTools PRD
Index	139520N
Working Pressure [bar]	6,3
Air consumption [l/min]	99,1
Rotational speed (RPM)	1.600
Power [kW/HP]	0,5/0,7
Stroke [mm]	-
Air inlet	1/4"
Working handle / thread	-
Working disc / paper / saw blade / hole / reamer [mm]	8x44
Maximum depth of metal sheet [mm]	3
Noise level [dB(A)] in idle /operation	85/82
Air outlet	handle
Length [mm]	270
Weight kg	2,2

CE



• NTools RDS 3

Cobalt-Steel Reamer Fluting Cutter

Reamer made from high-speed cobalt steel (HSSCo) resistant to high temperature. Fitted with cutter arbor. Features with very high mechanical strength. The tool is purposed for centre punching of car body welds and dismantling of car body elements including mudguards, wheel arches etc

➤ ADVANTAGES

- Special cutter for drilling of car body welds.
- Cobalt alloy centrally fixed blade- specially sharpened, eliminates unnecessary centre punching.
- Stable and strong construction enables work in difficult conditions.
- Packed individually to facilitate storage.

APP NO.	Description	Size
350492	RDS 3N	8 x 44 mm



• NTools RDS 4

Reamer Fluting Cutter For Boron Steel

Reamer with triple blade, made from cobalt steel, additionally covered with special titanium nitride coating (HSCo/TiALN) to improve strength and resistance to high temperature. Thanks to this structure it is a good solution for cutting/drilling of car body welds of the following make: Daimler-Chrysler, Mercedes, BMW, Opel, Porsche, Audi, Honda, Volvo, Peugeot, Citroen.

➤ ADVANTAGES

- Cutter with three cutting blades.
- Eliminated unnecessary centre punching.
- Durability improved three times comparing to traditional cutters.
- Special TiLAN coating that ensures extraordinary resistance to oxidation.
- Packed individually to facilitate storage.

APP NO.	Weight
350498N	44 x 8 mm



• NTools RDS 1

Cobalt-steel spot weld drill

NTools RDS ON/RDS 1 N relate to professional milling tools (cutter) purposed for centre punching of car body welds. NTools RDS ON/RDS 1 N have been made from cobalt steel, namely an alloy with addition of chromium, molybdenum, vanadium, tungsten and cobalt what ensure very good thermal and mechanical resistance. Cobalt-steel reamers are purposed for body shops to use during dismantling of car body elements including mudguards, wheel arches etc ..



➤ ADVANTAGES

- Special cutter for drilling of car body welds.
- Cobalt alloy fixed centrally blade- specially sharpened, eliminates unnecessary centre punching.
- Stable and strong construction enables workin difficult conditions with manual drill.
- Packed individually to facilitate storage.

! THE REAMERS ARE NOT DESIGNED TO WORK WITH THE 139520N PNEUMATIC REAMER, BUT CAN WORK WITH THE 139610N PNEUMATIC DRILL.

APP NO.	Description	Size
350490	RDS 0N	6 x 65 mm
350491	RDS 1N	8 x 75 mm



• NTools PFD

Pneumatic punch and flange tool

Pneumatic punch and flange tool NTools PFD is used for making edges, seams (tooth, step) and holes (with a diameter of 5 mm for a weld or seam) in order to professionally join steel sheets. The device has a rotating head, on one side a special stamp for making seams, on the other side a punch. The device is ideal for replacing the sill trim or inserting new fenders. There is then no need to use a drill to drill holes for the welds. Thanks to the NTools PFD folding punch, sheet metal joints of a car body or other sheet metal elements can be made quickly and professionally.

➤ ADVANTAGES

- The possibility of making edges, seams (tooth, step) and holes (with a diameter of 5 mm for a weld or seam)
- It is ideal for replacing sill plating or inserting new fenders, then there is no need for a drill, to drill holes for welds.
- fast and professional execution of sheet metal connections of car body or other sheet metal elements with a thickness of sheet metal max. 1.6 mm.

➤ FEATURES

- punch and flange metal sheets up to 1.6 mm thick
- diameter of made holes Ø 5mm for welding or seaming
- air consumption - only 113 l/min, gives the possibility to use a compressor with lower capacity

➤ PACKAGING CONTENT:

- NTools PFD - punch and flange tool
- ¼" air inlet, male thread
- NTools PNT 30 - Oil for pneumatic devices, 30 ml (APP NO. 89400)
- User manual with a warranty card



Model	NTools PFD
Index	139510N
Working Pressure [bar]	6,2
Air consumption [l/min]	113
Air inlet	1/4"
Hole [mm]	5
Maximum depth of metal sheet [mm]	1,6
Air outlet	back
Length [mm]	250
Weight kg	1,15



• NTools PP

Pneumatic saw

NTools PP pneumatic saw (reciprocating) is purposed for cutting of metals, plastic and glass fibre. It is perfect for sheet metal work. It features with high speed and power, as well as small consumption of compressed air. High class air driven engine features with low noise and vibration. You can choose cutting direction to ensure optimal work comfort for operator. An ergonomic, rubberized handle ensures a firm grip.

➤ ADVANTAGES

- High power and high quality blades for cutting of steel sheet up to 1.6 mm thick
- High performance - up to 10000 cycles (strokes) per minute to provide quick and smooth cutting.
- An adjustable bracket that facilitates work and control of cutting depth.
- Low noise level and vibration to ensure work comfort.
- Compact body and low weight to enable work at hard-to-reach places.
- Small air consumption - as little as 56.63 L/min. You can use a compressor of low output.

Model	NTools PP
Index	139500N
Working Pressure [bar]	6,3
Air consumption [l/min]	56,63
Rotational speed/ idle mode [RPM]	10.000
Stroke [mm]	10
Air inlet	1/4"
Blade [mm]	93
Maximum depth of metal sheet [mm]	1,6
Noise level dB(A) on idle /operation	82/95
Air outlet	front
Length [mm]	235
Weight kg	0,8

➤ PACKAGING CONTENT:

- Pneumatic saw including blade
- Spare blade (1 item)
- Spare bracket for cutting depth adjustment (1 item)
- Allen keys (2 items.)
- Compressed air supply quick-coupling 1/4" outer thread.
- Lubricating oil (30 ml).
- User manual.

➤ FEATURES

- Max. steel sheet thickness 1,6 mm
- Stroke length - 10 mm
- Air consumption as little as 56,63 l/min
- Rotational speed 10000 cykl/min



• NTools ACC-17

Blade for pneumatic saw NTools PP

ACC-17 blade (24 teeth) for pneumatic bayonet blade designed for cutting metals, plastics and glass fiber products. Perfect for sheet metal work.

Model	NTools ACC-17
Index	139905
Description	24 TPI
Sales unit	set (5 pcs.)



• NTools PPT

Pneumatic Band File

Professional band file compatible with endless abrasive tapes sized 10 x 330 mm. Perfect for coarse and precise grinding. Thanks to specific design it provides precise and efficient grinding of hard to access surfaces including curves, pipes, corners that pose a challenge for traditional grinders. It is a perfect solution for sharp edges blunting, and thanks to head position angle adjustment it can be purposed for different uses. Perfect for removal of welds, welding joints and grinding.

➤ ADVANTAGES

- Vibration free and stable operation to ensure comfortable work.
- Quick and easy replacement of tape thanks to specially Designed head leading the abrasive tape.
- Ergonomic, light and robust body and a rubberized handle that Ensures a secure grip and operation with one hand.
- Telescopic tensioner for abrasive tape tensioning and grinding of hard to reach surfaces.
- Head angle adjustment according to machined surface.

➤ PACKAGING CONTENT

- NTools PPT - Pneumatic Band File
- Endless abrasive belts - 3 items. (P80/P100/P120)
- APP ZL 2 - Air adapter 1/4", outer thread
- NTools PNT 30 - Lubricating oil (30 ml)
- User Manual + Guarantee Card



Model	NTools PPT
Index	139300N
Working Pressure [bar]	6,3
Air consumption [l/min]	311
Rotational speed [RPM]	16.000
Power [kW/HP]	0,3/0,38
Air inlet	1/4"
Abrasive tape dimensions [mm]	10x330
Noise level dB(A) idle / operation	87/-
Air outlet	back
Length [mm]	284
Weight kg	0,8



• NTools 722 SG

10 mm x 330 mm ceramic endless sanding belts

Endless abrasive belts with ceramic coating on a base of reinforced, flexible, technical polyester fabric. Intended for rough grinding of stainless and acid-resistant steel, tool and hardened steel, structural and carbon steel and non-ferrous metals. They are available in 4 gradations: P40, P60, P80, P120 and are sold in sets of 10 pcs. The tapes in cooperation with the NTools PPT 139300N pneumatic band file are ideal for grinding tight, hard-to-reach places such as: spherical surfaces, pipes, corners, etc.

➤ ADVANTAGES

- high tear resistance while maintaining adequate flexibility
- high efficiency with moderate temperature increase of the workpiece
- firmly embedded abrasive guarantees high performance at medium pressures
- possibility of dry and wet work



APP NO.	Description	Weight / Size	Sales unit
06TSC0040	P40	10 x 330 mm	pack. (10 pcs.)
06TSC0060	P60	10 x 330 mm	pack. (10 pcs.)
06TSC0080	P80	10 x 330 mm	pack. (10 pcs.)
06TSC0120	P120	10 x 330 mm	pack. (10 pcs.)



• NTools PSP

Air-Driven Straight Grinder

Short, handy, powerful. It has a light structure and a toggle switch with a lock protecting against accidental switching on. Rear Air Outlet in the handle keeps the workplace dust-free. Working holder on a Pin with a diameter of 6mm. The grinder is designed for processing metal, stone, wood and plastics. Designed for grinding, polishing and smoothing sharp edges, welds and small, hard-to-reach gaps and holes. The device can be used to remove corrosion centers or seals. Perfect for small sheet metal works.

➤ BUDOWA

- COMPACT AND ROBUST: Made from strong and high quality materials that offer high performance and resistance to work conditions.
- COMPACT BODY: Small-size casing and low weight ensure total work comfort, also in case of hard-to-reach surfaces.
- TROTTLING VALVE: Provides for smooth control of operating speed in range of 0-22000 RPM.
- SWITCH LOCK: Prevents against an accidental operation and ensures total safety during work.

➤ APPLICATION

- Works related to machining of metal, stone, wood and plastic,
- Grinding, polishing and deburring of sharp edges, welds as well as small and hard-to-reach slots and holes,
- Works related to removal of gaskets and rust,
- Paint and body repairs.

PAINT & BODY SHOPS, SMITHERIES, FOUNDRIES AND WORKSHOPS

➤ PACKAGING CONTENT

- NTools PSP- Mini air-driven straight grinder.
- APP ZL 2 - Air adapter in: outer thread.
- NTools PNT 30 - Lubricating oil, 30ml.
- 2 x key for mandrel and air adapter fixing.
- User Manual along with the Guarantee Card.

➤ ADVANTAGES

- Working head including chuck fixing mandrel 6mm (1/4").
- Air outlet that prevents dusting at work place.
- Compressed air pressure consumption - 793L/min
- Perfectly balanced body that reduces vibration, ensures comfort and precision during work.
- High performance 0.4kW [0.6HP] engine that offers perfect torque and maximum speed 22000 RPM.



➤ TECHNICAL DATA

Model	NTools PSP
Index	139100N
Working Pressure [bar]	6,3
Air consumption [l/min]	793
Rotational speed [RPM]	22.000
Power [kW/HP]	0,4/0,6
Air inlet	1/4"
Working handle / thread	1/4" (6mm)
Noise level dB(A) idle / operation	93/102
Air outlet	back
Length [mm]	165
Weight kg	0,5



• NTools PW

Pneumatic drill 3/8"

NTools PW is a lightweight pneumatic drill designed for professional sheet metal, shop, industrial, assembly and carpentry work. It is suitable for long-term heavy-duty work, including drilling, honing and sawing holes in steel, cast iron, bronze, copper, light alloys, plastics, and wood. Ideal for use in spaces with limited room to maneuver. High performance air motor for low noise and vibration. Pistol-style, ergonomic design and rubberized handle provide comfortable work and a secure grip. The quick-change, self-clamping drill chuck allows easy and quick replacement of drill bits, cutters or discs on the shank.

➤ ADVANTAGES

- SMALL SIZE AND LIGHTWEIGHT HOUSING - for working in hard-to-reach places.
- EFFICIENT MOTOR WITH A SIMPLE CONSTRUCTION - resistant to wear.
- MULTI-STAGE PLANETARY GEAR - for constant speed and power at start-up.
- JACOBS® SELF-CLAMPING HANDLE - Self-clamping jacobs® handle for quick drill, cutter, and arbor changes.
- HIGH ROTATIONAL SPEED - The drill has a speed of 3200 RPM which makes drilling fast and efficient.
- REVERSIBLE ROTATION FUNCTION (LEFT/RIGHT) - by means of a convenient switch at the trigger.
- LOW NOISE LEVEL - thanks to the air outlet silencer in the handle.
- LOW AIR CONSUMPTION- Only 113 l/min - makes it possible to use a compressor with a lower efficiency

➤ ACCESORIES

- with abrasive discs d100mm APP NO. 06X100, abrasive discs d150mm APP NO. 06X150, abrasive discs Pressed discs d115mm APP NO. 06XC115 fitted with the APP NO. 06X900
- NTools Rust Set 139610NSET wire brushes
- Cobalt-steel reamers (cutters) d6mm x 65mm APP NO. 350490 and d8mm x 75mm APP NO. 350491

➤ PACKAGING CONTENT

- pneumatic drill,
- compressed air quick connector 1/4" exterior thread,
- oil for pneumatic devices (30 ml),
- instruction manual.

Model	NTools PW
Index	139610N
Working Pressure [bar]	6,2
Air consumption [l/min]	113
Rotational speed [RPM]	3.200
Power [kW/HP]	0,33
Air inlet	1/4"
Working handle / thread	3/8"-24
Noise level dB(A) idle / operation	89 / 100
Air outlet	back
Length [mm]	185
Weight kg	1.15



• NTools PSK

Pneumatic rotary grinder with collet chuck for 6 mm mandrels

NTools PSK is a pneumatic, high-speed mini rotary grinder, designed to work on small surfaces and in hard-to-reach places when grinding metal, plastic, wood, etc. The clamping handle is adapted to cooperation with d6 mandrel for attaching the d50 NTools Fast LOCK™ working disc (APP NO. 06FLU0002).

➤ ADVANTAGES

- compact and reliable structure
- very good balance
- acceptable levels of volume and vibration
- little need for compressed air
- ergonomic, rubberized handle for a secure grip, comfort and precision during long-term work
- durable bearings and turbine blades
- trigger lock to prevent accidental activation

➤ PACKAGING CONTENT

- NTools PSK grinding machine
- 1/4" air inlet, male thread
- NTools PNT 30 pneumatic equipment oil
- two keys to lock the chuck
- user manual with warranty card

➤ TECHNICAL DATA

Model	NTools PSK
Index	139102N
Working Pressure [bar]	6,3
Air consumption [l/min]	53,8
Rotational speed [RPM]	20.000
Power [kW/HP]	0,2/0,3
Air inlet	1/4"
Working handle / thread	1/4" (6mm)
Noise level dB(A) idle / operation	74,5/ 87,5
Air outlet	back
Length [mm]	136
Weight kg	0,63



APP NO. 139102N

• System NTools Fast LOCK

NTools Fast LOCK System is a perfect solution for all applications where small items and hard-to-reach areas have to be treated. A specially designed holder provides a very quick tool change in less than 5 seconds.

➤ ADVANTAGES

- very fast tool change reducing downtime compared with tools with conventional mounting,
- one holder - several different tools,
- ability to work in hard-to-reach areas,
- quick treatment of small items,
- compatible with Norton Speed-Lok and 3M Roloc.

NTools Fast LOCK TM ➤ Clamping plate d50 with TR coupler and 6 mm shank

Flexible backing pad with a diameter of 50 mm with a quick mounting system for abrasive material. It has a mounting pin with a diameter of 1/4" (6 mm) designed for clamping chucks of rotary high speed grinders, eg NTools PSK. Maximum speed 30,000 RPM.

APP NO.	Pin	Size	Sales unit
06FLU0002	6 mm	d50	pack. (2 pcs.)
06FLU0002B	6 mm	d50	pack. (25 pcs.)



NTools Fast LOCK KS ➤ Abrasive disc d50 blue with TR connector

abrasive discs covered with zirconium on a canvas lining intended for machining of all common used metals. Grain gradation range P40 - P120. Thanks to application of zirconium grit, its abrasive characteristics and efficiency are much higher in comparison to conventional electro corundum grain. A tool for aggressive grinding of steels and welds, removal of large excess materials during a coarse and intermediate machining and removal of spatter during welding. Maximum working speed of 20,000 RPM.

APP NO.	Gradation	Color	Size	Sales unit
06FLK0040	P40	blue	d50	pack. (10 pcs.)
06FLK0060	P60	blue	d50	pack. (10 pcs.)
06FLK0080	P80	blue	d50	pack. (10 pcs.)
06FLK0120	P120	blue	d50	pack. (10 pcs.)
06FLK0040B	P40	blue	d50	pack. (100 pcs.)
06FLK0060B	P60	blue	d50	pack. (100 pcs.)
06FLK0080B	P80	blue	d50	pack. (100 pcs.)
06FLK0120B	P120	blue	d50	pack. (100 pcs.)

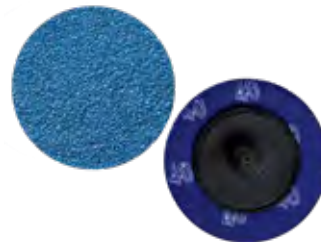

NTools Fast LOCK DS ➤ Abrasive disc d50 black made of a hard fleece with a TR connector

An open non-woven structure allows for aggressive treatment without lumping and gouging. Thick nylon fibre and very coarse grain is designed for: removal of various types of coatings including sealants, rust, weld spatter and scale, to be used before and after welding in order to prepare and clean the surface.

APP NO.	Color	Size	Sales unit
06FLD0002	black	d50	pack. (5 pcs.)
06FLD0002B	black	d50	pack. (25 pcs.)

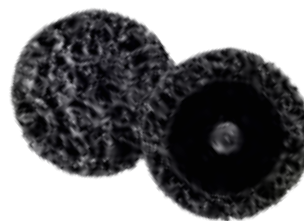

NTools Fast LOCK WS ➤ Three grit d50 abrasive fleece with TR connector

Non-woven abrasive material resistant to tearing by sharp edges, smoothing and cleaning without smudging.

Available in three grit variants:

- fine-grained (blue colour)
- medium-grained (red colour)
- coarse-grained (brown colour)

Intended for finishing work including removal of rust and coatings, cleaning castings, removal of contaminants and old seals, smoothing surface imperfections.

APP NO.	Description	Color	Size	Sales unit
06FLW0001	fine grain	blue	d50	pack. (5 pcs.)
06FLW0002	medium grain	red	d50	pack. (5 pcs.)
06FLW0003	coarse grain	brown	d50	pack. (5 pcs.)
06FLW0001B	fine grain	blue	d50	pack. (50 pcs.)
06FLW0002B	medium grain	red	d50	pack. (50 pcs.)
06FLW0003B	coarse grain	brown	d50	pack. (50 pcs.)



ADVANTAGES

01 Rotational speed control throttle valve for optimal operating speed within range 0-4000 rpm

02 Two-stage trigger for working speed in the range of 0-4000 rpm.

03 A wide range of accessories:
 - wire wheel brushes
 - abrasive disks
 - rubberized hard disk
 that quickly remove old coats, corrosion, sprayed paints, filler, adhesive tapes and stickers, as well as emblem related glue residues.



More informations



• NTools PSRN 2

Pneumatic grinder
for rust and sticker removal

NTools PSRN 2 Grinder with exhaust system purposed for removal of filler, putty, rust, stickers with flexible brush tapes which easily adapt to edges and body shape. Elements cleaned with the brushes have appearance similar to sanding effects while the cleaned surface is not deformed. Comparing to traditional abrasive disks the grinder ensures higher efficiency. The set includes: Grinder; Metal brush tape - 3 different types: Coarse - 23mm wide; d103mm; 0.5mm wire; Medium - 23mm wide; d103mm; 0.5mm wire; Finish - 23mm wide; d103mm; 0.5mm wire; 23mm brush adapter; 100mm abrasive disk along with adapter; Disk for removal of tapes and stickers along with adapter (external d103mm, and internal d30mm).

> PACKAGING VOLUME

- pneumatic grinder
- coarse wire wheel brush: Width: 23 mm; ø103 mm; wire 0,7mm (APP No. 139933)
- fine wire wheel brush, Width: 23 mm; ø103 mm; Wire .0.5 mm (APP No. 139935)
- abrasive disk 100 mm + adapter outer dia.. ø103 mm, inner dia. ø30 mm (APP No. 139931)
- disk for tape and sticker removal, + adapter, outer dia.. ø103 mm, inner dia. ø30 mm (APP No. 139930)
- plastic case
- key flat
- 5/16" thread adapter - 24 turns to M4 x1 thread
- quick-coupling 1/4"
- allen key



> TECHNICAL DATA

CE

APP NO.	139352P
Working Pressure	6,2 bar
Air consumption	99 l/min
Rotation speed	4000 RPM
Power output	373/0,5 kW/HP
Air connection	1,4"
Noise level	104,1 dB(A)
Vibration level	1,8 m/s ²
Weight	1,4 kg

• NTools PZSS

Pneumatic car windshield cutting kit

The NTools PZSS is a tool kit designed for professional and quick replacement of car windshields using blades designed and shaped specifically for that purpose. The kit features a pneumatic knife and a set of 5 blades varied in terms of size and shape. Additionally, the kit is complemented by two suction cups with a diameter of 115 mm and a belt with a clamp for pulling out and transporting the cut glass panels. The kit is packaged in a sturdy plastic carrying case.

➤ ADVANTAGES

- 5 blades varied in terms of size and shape
- stroke of 3 mm and high blade working speed up to 20000 cycles/m
- 2 articulated, two-sided suction cups with a diameter of 115 mm and a clamp for pulling out and transporting cut glass panels



➤ TECHNICAL DATA

Type	NTools PZSS
Indeks	139570N
Working pressure [bar]	6,2 bar
Air consumption [l/min]	113 l/min
Idle strokes [BPM]	20000 cykli/min
Power [kW/HP]	0,33 KM
Stroke [mm]	3 mm
Air inlet	1/4"
Air outlet	tyt
Working handle with thread	5/16"-24
Noise level: idle / operating	78 / 89 dB(A)
Knife length	195 mm
Knife weight	0,97 kg
Blades (5 pcs.)	57 / 90 / 50 / 35 / 24 mm
Suction cups (2 pcs.)	ø115 mm
Belt with buckle	4,5 m



CE

The knife (saw) is compatible with glass cutting blades available in the APP offer:

APP NO.	Product name	Length	Photo
139910*	APP ODS 1 Straight blade for glass cutting saw	57 mm	
139911*	APP ODS 2 Straight blade for glass cutting saw	90 mm	
139912	APP ODS 3 Hooked blade for glass cutting saw	18 mm	
139913	APP ODS 4 Hooked blade for glass cutting saw	36 mm	
139914	APP ODS 5 Hooked blade for glass cutting saw	60 mm	
139915	APP ODS 6 Hooked blade for glass cutting saw	90 mm	
139916*	APP ODS 7 Thin bent blade for glass cutting saw	50 mm	
139917	APP ODS 8 Straight blade for glass cutting saw	8 mm	
139918*	APP ODS 9 Straight blade for glass cutting saw	35 mm	
139919	APP ODS 10 Straight, thin, serrated blade for glass cutting saw	35 mm	
139920	APP ODS 11 Bent, thin blade for glass cutting saw	35 mm	
139921*	APP ODS 12 Hooked blade for glass cutting saw	24 mm	

* *Blades included in the NTools PZSS kit.

• NTools PSM30

Pneumatic d30/1,5 vibration grinder for inclusion removal + working disc NTools TR 30

The NTools PSM30 is a pneumatic mini vibration grinder designed for removing inclusions and other contamination from the surface of cured lacquer, and work with small scratches. It can be used for thorough grinding of edges and rims, and for work with difficult to reach areas.

> ADVANTAGES

- vibration motion with a stroke of 1,5 mm for P15000 or P2000 allows quick restoration of gloss (re-polishing) on the processed surface
- very good balance
- two-stage trigger
- low compressed air requirement
- ergonomic, rubberized handle ensuring a secure grip, comfort and precision during extended work
- low noise and vibration level
- durable bearings and turbine blades
- trigger lock preventing accidental activation
- two durable d30/M10 work disks, one fastened with adhesive, compatible with APP MX and APP PSK pads, and Velcro-fastened, for work with APP MXR Velcro pads



> PACKAGING CONTENT

- NTools PSM30 grinder
- two work disks: NTools TR30 Velcro (APP No. 150540) and adhesive-mounted (A)
- NTools ZL 4 quick connector plug
- NTools PNT 30 pneumatic tool oil
- instruction manual and guarantee card



> TECHNICAL DATA

Model	NTools PSM30
Index	139210N
Working pressure [bar]	6,3
Air consumption [l/min]	17,55
Vibration frequency [RPM]	7.500
Power [kW/HP]	0,2/0,3
Stroke [mm]	1,5
Air connection	1/4"
Work disk mounting	M10
Paper [mm]	30
Noise dB(A) idle / work	87/97
Air outlet	tyt
Length [mm]	168
Weight kg	0,63



APP NO. 150542
APP NO. 150540

NTools TR 30
Working disc d30 for NTools PSM30 grinder
APP NO. 150542 - on the GLUE / APP NO. 150540 - on the VELCRO

> Cooperates with flakes 35 mm i 32 mm



ON THE VELCRO

P1500 APP NO. 40MXR1500	P2000 APP NO. 40MXR2000	P2500 APP NO. 40MXR2500
----------------------------	----------------------------	----------------------------



ON THE GLUE

P1500 40MX1500	P2000 40MX2000	P2500 40MX2500	P5000 40MX5000
-------------------	-------------------	-------------------	-------------------

ON THE GLUE

P1500 40PSK1500	P2000 40PSK2000
--------------------	--------------------

• NTools PSM50

Pneumatic eccentric d50/3 grinder for small surfaces d50/3
+ working disc NTools TR 50

The NTools PSM50 is a pneumatic eccentric mini-grinder intended for working in difficult to reach areas and applications in grinding edges and rims. The Velcro-fastened work disk is compatible with APP KR 50 abrasive disks.

➤ ADVANTAGES

- compact and reliable construction
- two-stage trigger
- very good balance
- acceptable noise and vibration level
- low compressed air requirement
- ergonomic, rubberized handle ensuring a secure grip, comfort and precision during extended work
- durable bearings and turbine blades
- trigger lock preventing accidental activation

➤ PACKAGING CONTENT

- NTools PSM50 grinder
- NTools TR50 Velcro (APP No. 150544) work disk
- NTools ZL 4 quick connector plug
- NTools PNT 30 pneumatic tool oil
- work disk detachment key
- instruction manual and guarantee card

➤ TECHNICAL DATA

Model	NTools PSM50
Index	139200N
Working pressure [bar]	6,3
Air consumption [l/min]	52,95
Vibration frequency [RPM]	15.000
Power [kW/HP]	0,2/0,3
Stroke [mm]	3
Air connection	1/4"
Work disk mounting	5/16"-24 UNF
Paper [mm]	50
Noise dB(A) idle / work	87/97
Air outlet	tyt
Length [mm]	168
Weight kg	0,71



APP NO. 139200N



APP NO. 150544

Velcro backing disc with a diameter of 50 mm mounted on a 5/16 thread: UMF for Velcro sandpaper with a diameter of 50 mm without holes. Designed to work with the NTools PSM50 grinder.



• NTools HG LED

Heat gun with temperature control and LED indicator

NTools HG LED - LED temperature indicator placed in a single row on the top of the heat gun housing, three-position switch used to select one of the two temperature ranges and the blow air flow rate. LED indicator indicating current temperature values. Set the temperature heating up using the buttons (+/-) on the control panel. 2 air flow settings (250 L/min. and 550 L/min.) Efficient engine 2000 W, wide range of temperature adjustment from 50°C to 600°C, last used temperature record (even when the tool was disconnected from the power supply), rubberised handle for optimal comfort during operation, large three-step switch to make working in protective gloves easier, double thermal insulation to prevent overheating of the tool and enable its continuous operation, can be used in combination with heated air stream shaping nozzles.

➤ ADVANTAGES

- air heat gun 2000 W ensures rapid start-up, efficient operation and high maximum temperature
- adjustable air flow from 150 to 550 litres/min. provides additional parameter adjustment of the heat gun to the work performed
- lightweight, durable construction of the heat gun guarantees its strength and reduces fatigue during operation
- vertical construction of the heat gun allows for its vertical operation as a stationary device and machining the work piece with both hands
- electronic temperature adjustment module enables step (NTools HG LED) or variable (NTools HG LCD) temperature adjustment from 50°C to 600°C.
- partially rubberised D-shaped handle guarantees a secure and comfortable grip and improves work ergonomic prevents accidental burns to the operator's hand with the work piece
- built-in double thermal isolation prevents overheating of the device and burning of the heating element

➤ PACKAGING CONTENT

- heat gun NTools HG LED
- user manual with a warranty card

APP NO.	Description	Weight
126007	2000 W	0,75 kg



view video



• NTools HG LCD

Heat gun with electronic temperature adjustment and LCD display

NTools HG LCD 2000 W electric heat gun with smooth, electronic temperature adjustment in a range from 50°C do 600°C and step air flow adjustment in a range from 120 L/min to 500 L/min. It is characterized by an aesthetic and modern design, ergonomic frame and ease of use. The heat gun features an LCD display that indicates the selected temperature and air flow strength. Additionally, it has a cooling function – when the switch is set to the "1" position (constant temp. of 50°C), and the ability to switch the temperature units °C/F. The NTools HG LCD heat gun is used for heating, searing, defrosting, drying, removing stickers and old paint coats, heating up seared threaded connection in order to facilitate their unscrewing, application of edge veneers, shrinking of heat-shrink covers, etc.

➤ ADVANTAGES

- air heat gun 2000 W ensures rapid start-up, efficient operation and high maximum temperature
- adjustable air flow from 150 to 550 litres/min. provides additional parameter adjustment of the heat gun to the work performed
- lightweight, durable construction of the heat gun guarantees its strength and reduces fatigue during operation
- vertical construction of the heat gun allows for its vertical operation as a stationary device and machining the work piece with both hands
- electronic temperature adjustment module enables step (NTools HG LED) or variable (NTools HG LCD) temperature adjustment from 50°C to 600°C.
- partially rubberised D-shaped handle guarantees a secure and comfortable grip and improves work ergonomic prevents accidental burns to the operator's hand with the work piece
- built-in double thermal isolation prevents overheating of the device and burning of the heating element

➤ PACKAGING CONTENT

- NTools HG LCD heat gun
- 4 nozzles shaping the blown air stream
- 3 different shape scrapers for removing old paint, varnish and glue
- spatula
- transport case
- user manual with a warranty card

APP NO.	Description	Weight	Package
126008	2000 W	0,78 kg	case + accessories 1 pcs.



view video



• NTools A211

Spray gun with recirculation (700g FREE corundum)

Corund purposed for A211 Sanding Gun (APP No. 388050), namely used in case of sanding of small corroded surfaces. Fitted with 4 heads and consumes 100 - 500 litres of air per minute. Application: Sanding of wheel rims, vehicle body and underbody, motorcycle body, engine components - does not result in surface corrosion; Stone treatment (e.g. gravestone lettering); Glass treatment (matt finish, engraving).

➤ PACKAGING CONTENT

- 4 types of rubber end nozzles, to be used depending on the sandblasted surface
- 700 g of corundum
- user manual with a warranty card

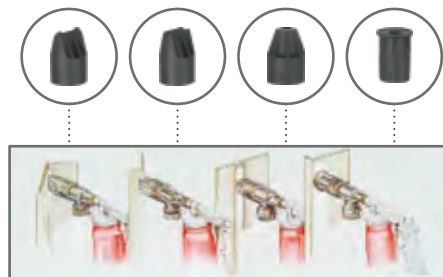

APP NO.	388050
Air consumption	500 l/min
Working pressure	10 bar



+ 700g corundum
GRATIS!



• APP KDP

Corundum blasting gun

Corundum purposed for A211 Sanding Gun (APP No. 388050), namely used in case of sanding of small corroded surfaces. Fitted with 4 heads and consumes 100 - 500 litres of air per minute. Application: Sanding of wheel rims, vehicle body and underbody, motorcycle body, engine components - does not result in surface corrosion; Stone treatment (e.g. gravestone lettering); Glass treatment (matt finish, engraving).

➤ ADVANTAGES

- does not rust the surface

➤ APPLICATION

- sandblasting of rims, engine parts, bodies and chassis in cars and motorcycles
- stone processing (e.g. tombstone lettering)
- glass processing (matting, engraving)

APP NO.	Volume net
388052	700 g



• NTools BM1

Anvil - type convex

Popular shaping tools made from high grade steel.

APP NO.	Product name
360771	NTools BM1



• NTS BM2

Anvil - type heel

Popular shaping tools made from high grade steel.

APP NO.	Product name
360772	NTools BM2



• NTools MB-1

Platypus hammer

A perfectly balanced tinsmith's hammer. Round foot, the beak is flattened in the form of a wedge transversely to the handle. Made of high quality steel. The great advantage of the hammer is the hickory handle, which is characterized by the fact that it does not transfer vibrations to the handle (recoil hammer).

APP NO.	Product name
360751	NTools MB-1



• NTS MB

Hammer with a large foot (stork)

Hammer for auto body repairs, with a big round peen, covered with a top coat with the solid wood shaft.

APP NO.	Product name
360752	NTools MB



• NTS MDW

Hammer circular duplex (Teflon-rubber)

Precise small hammer with the round beaters for auto body repairs, with Teflon and rubber beater. Peen diameter around 12mm. Purposed mostly for finishing works or non-invasive repairs made on the top coat.

APP NO.	Product name
360753	NTools MDW



• NTools HB 350

Hebel tin to the body 350 mm

NTools HB 350 is a robust plane made from light alloys purposed for work with NTools 9 and 12 TPI car body rasp. Plane is used for treatment of materials namely steel and tin during works related to car body tinning.

Tool is fitted with the roman screw that allows adjustment of rasp in three planes (flat, hollow, convex) according to shape of particular car body element.

Working surface: 350 x 35 mm



APP NO.	Size
360250	350 mm

• NTools 9 TPI / 12 TPI

Rasp to hebel tinsmith tools

- coarse (input) / finishing equipment (contribution)

1 NTools 9 TPI Plane Rasp (Coarse) double-side rasp purposed for NTools HB350 plane. The coarse rasp provides tin initial treatment (removal of excessive material) during tinning. Thanks to flexibility the tool works well on any car body surface. One inch (2.54cm) of rasp surface includes 9 sharp cutting edges.

2 NTools 12 TPI Plane Rasp (Finishing) double-side rasp purposed for NTools HB350 plane. The finishing rasp provides tin finishing treatment (removal of excessive material) during tinning. Thanks to flexibility the tool works well on any car body surface. One inch (2.54cm) of rasp surface includes 12 sharp cutting edges.

Dimensions: 350 x 35 x 5 mm

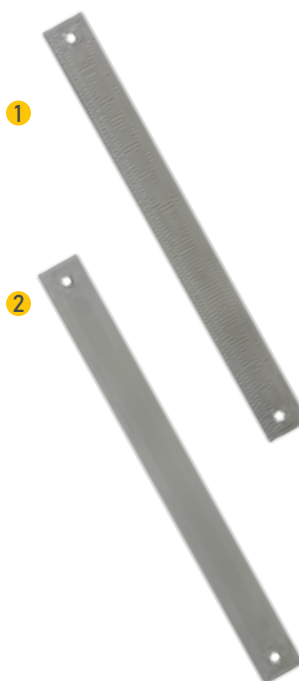

APP NO. 360255



APP NO. 360260

APP NO.	Description
360255	rasp to hebel tinsmith tool - coarse (input)
360260	rasp to hebel tinsmith tool - finishing equipment (contribution)

• NTools PBL 2

Tinsmith gauge

Rule (shape gauge) enables precise measurements of car body curve. This gauge enables to replace any edges, arches, curves and depressions of car body and other angular profiles. Working principle: Place the rule against the curved surface purposed for repair and replacement. The kit includes: Two items of rule; Angle-arch connector joining two rules; The whole kit is delivered in plastic box.

➤ SET CONTAINS

- two items of rule
- angle-arch connector joining two rules

The whole kit is delivered in plastic box.

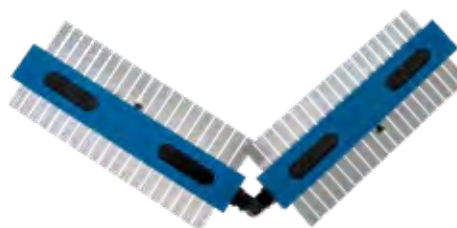

APP NO.	Size	Sales unit
360200	2 x 20 cm	pack. (2 pcs.)

BODYWORK REPAIR



Car body repair
non-invasive methods

305-351 BODYWORK REPAIR

- 305 - 306 Panel repair sets
- 307 - 312 Spotters and accessories
- 313 - 318 Consumables for spotters: electrodes, rivets, triangles
- 319 - 320 Welding: wires, nozzles, grips
- 321 - 324 Panel repair tongs
- 325 - 328 Spreaders, pullers and clamps
- 329 - 342 Specialized body repair tools
- 343 - 348 • Car body repair - non-invasive methods**
- 349 - 351 Welding: OHS

• NTools Puller Set

Removal Kit dents

NTools Puller Set is purposed for professional use during painless dent repairs. Car body dents most often are caused by: hail; fall of objects hitting against the car body (e.g. chestnut, walnut etc.); hitting against door.

> ADVANTAGES

- a set of tools for the adhesive method
- suitcase that allows you to keep order and completeness of the set
- kit mobility

APP NO.	Description
351750	The set includes all the necessary tools for work during varnish-free removal of dents using the adhesive method - Puller, glue gun, glue, a set of mushrooms, a sample of the W900 remover, three mallets and a hammer.



• NTools PNK / NTools PNKG

Puller for adhesive repairs / Foam pads for Puller PNK

APP Puller is an universal device purposed for small dent repairs wit use of adhesive. Operation with one hand enables quick repairs of small dents. Compact body facilitate use on even smallest tightest surfaces. This aluminium device features with lightweight and comfort of work. Movable feet are provided with rubber plates that protect car body against scratches, ensure shock absorption during work and align against car body surface. Puller working height adjustment with a knob enables to use a working tip appropriate to the tab.

NTools PNKP - a set (left + right) of microgum washers . They are file with glue layer to attach the glue puller soles NTools PNK pads have a 4mm thickness and are very soft and flexible . They do not leave any traces on the vehicle bodys.

APP NO.	Description	Length	Width	Height	Thickness	Weight	Sales unit
351551	Puller for adhesive repairs	21,5 cm	8,5 cm	14,5 cm	-	580 g	pcs.
351553	Foam pads for Puller PNK	-	-	-	4 mm	-	2 pcs.



APP NO. 351551



APP NO. 351553

• NTools PNP SET

Puller for spot repairs with accessories

Spot repair puller is an universal device purposed for dent repairs without application of top coat. It features with wide adjustment range of supports and tang that enables its use on any type of surface. Holding and closing puller handle results in tang upward movement. In addition precise control of pulling height is ensured. Puller is provided with spot electrode for dent pulling, spotter adapter and the handle for noninvasive pulling of dents with use of tabs glued to the top coat.

> The set includes::

- 1 tab handle - APP NO. 351552
- 2 adapter enabling connection of puller - APP NO. 351560
- 3 electrode adapter APP NO. 351558 for electrode APP NO. 351555
- 4 spot electrode for minor dents pulling - APP NO. 351555

Puller współpracuje z grzybkami na klej lub ze spoterem. Klej oraz grzybki na klej (adaptory PDR) są wyszczególnione na kolejnych stronach katalogu.

APP NO.	Description	Sales unit
351550	Puller for spot repairs with accessories	1 pcs.
351554	NTools PNP BAR - Crossbar for the puller for spot repairs 3541550 40cm	1 pcs.



APP NO. 351555

APP NO. 351558

• NTools MB1000 / MB400

Aluminum impact puller for suction cups

NTools PDR MB1000 Inertia Hammer is purposed for painless dent repairs. It is lightweight steel or aluminium device that it very convenient in use and ensures work comfort during car body repairs. Hammer is provided along with replaceable tab adapter compatible with almost any tabs used during painless dent repairs with glue pulling method. Total length 470 mm.

The NTools PDR MB400 impact puller is intended for paint-less removal of dents using the glue method. The instrument is made out of steel and aluminum. The low weight (400g) ballast is made out of aluminum, which makes the tool light and comfortable to use. The ergonomically profiled grip enables comfortable work during bodywork repair. The impact puller is equipped with a replaceable suction cup adapter ensuring the tool's compatibility with nearly any suction cup used during bodywork repairs involving glue. Total length 470 mm.



APP NO. 351886



APP NO. 351898

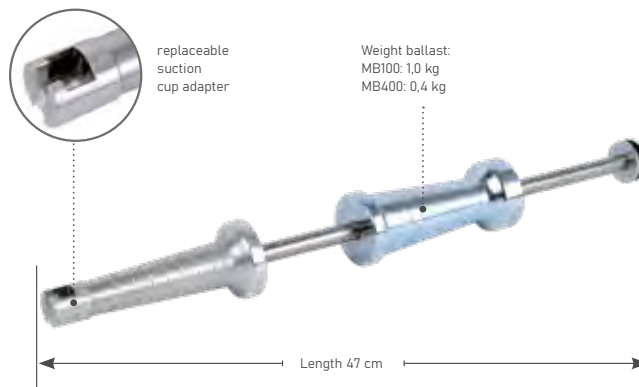

















APP NO.	Description	Packing
351886	aluminum impact puller for suction cups 1000g	1 pcs.
351898	aluminum impact puller for suction cups 400g	1 pcs.









ACCESSORIES FOR SPOT REPAIRS - PULLER

Photo	APP NO.	Description	Product information	QR CODE
	351552	Mushroom holder	Used for repairs with the use of hot glue. Attached to Puller 351550. Thread M10, material: aluminum.	to order
	351696	NTools G STICKS Universal- Hotmelt glue 250 g	All-purpose hot melt glue sticks purposed for painless dent repairs. NTools G-STICKS feature with improved adhesion to surface and ensures efficient repairs of car body dents. Glue sticks do not cause damage of top coat, quickly and uniformly dissolve and are elastic upon cooling. Dedicated for work with tabs for car body dent repairs and other NTools branded devices including: 351551 - Puller for NTools PNK repairs 351886 - ALU inertia hammer for NTools MB1000 Tabs	
	351695	NTools G STICKS BLACK Universal- Hotmelt glue 250 g	Adhesives are perfect for use in techniques varnishless dents PDR Characterized Technical data due to adhesion properties, which makes it possible to make transfers from sheet metal. Universal glue when it comes to o temperature range up to 0-26 ° C.	
	351685	NTools G STICKS BLACK Universal- Hotmelt glue 1 kg	Adhesives are perfect for use in techniques varnishless dents PDR Characterized Technical data due to adhesion properties, which makes it possible to make transfers from sheet metal. Universal glue when it comes to o temperature range up to 0-26 ° C.	
	351708	NTools TAB 13 Round spherical mushroom d11 red	NTools TAB 13 is an 11mm diameter round spherical mushroom made of durable plastic. The slightly convex design of the NTools TAB 13 causes an even distribution of forces on the repaired surface when pulling out a dent. The small diameter of the mushroom allows very precise finishing of the repaired surface of the car body. Dimensions of NTools TAB 13 Height: 20 mm, Neck diameter: 6 mm, Base diameter: 11 mm	
	351700	NTools TAB 5 Mushroom red round spherical d16 red	To be used with Puller 351550. Used for pulling of small dents.	
	351701	NTools TAB 9 Mushroom red round spherical d21 red	To be used with Puller 351550. Used for pulling of average sized dents.	
	351702	NTools TAB 6 Mushroom red round spherical d32 red	To be used with Puller 351550. Used for pulling of large dents	

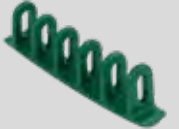

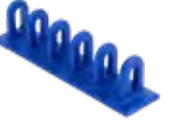

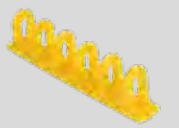



ACCESSORIES FOR SPOT REPAIRS - PULLER

Photo	APP NO.	Description	Product information	QR CODE
	351703	NTools TAB 7 Mushroom blue round flat D36	Stiff tab to be used with Puller. Purposed for pulling of dents using force.	
	351704	NTools TAB 10 Mushroom yellow round flat d40	Stiff tab to be used with Puller. Purposed for pulling of dents using force.	
	351705	NTools TAB 11 Mushroom yellow elliptical flat 33 x 47	Stiff tab to be used with Puller. Purposed for pulling of oval dents using force.	
	351706	NTools TAB 12 Purple cone round flat flexible d40	Elastic tab to be used with Puller. Purposed for gently pulling of dents.	
	351707	NTools TAB 8 Purple cone elliptical flat flexible 33 x 47	Elastic tab to be used with Puller. Purposed for gently pulling of oval dents.	
	351691	NTools TAB 1 Large flat mushroom Glue Pullera base diamete 20 mm	Used in case of big and shallow damages of surface.	
	351692	NTools TAB 2 Mushroom large spherical to Glue Puller, base diameter 20 mm	Used in case of big and deep damages of surface.	
	351693	NTools TAB 3 d12 mm blue, round, flat, very rigid tab, base diametery 20 mm	Used in case of small and shallow damages of surface.	
	351710	NTools TAB SET Set of dent pulling tabs, package (10 pcs.) 1 x round flat tab d=40mm 1 x round flat tab d=35mm 1 x round flat tab d=32mm 1 x spherical round tab d=25mm 1 x spherical round tab d=20mm 1 x spherical round tab d=15mm 1 x elliptical flat tab 48x33mm 1 x elliptical flat tab 40x22mm 1 x elliptical flat tab 33x22mm 1 x rectangular flat tab 32x17mm	Tab set purposed for dent repairs made with use of Puller and adhesive. Plastic composite tabs feature with improved strength. Set includes round, flat, spherical and elliptical tabs, as well as rectangular tabs.	
	351720	APP LWK 1 Pulling skirt - red multipad for glue 6 x 22 x 156 mm (1 pcs.)	Medium flat pull-out bar. They are used to remove large dents without damaging the paint coating. It can be trimmed to the desired Length. Extracting using a comb lining or adapters 351730, 351731.	

ACCESSORIES FOR SPOT REPAIRS - PULLER

Photo	APP NO.	Description	Product information	QR CODE
	351721	APP LWK 2 Pulling skirt - grey multipad for glue 6 x 50 x 156 mm (1 pcs.)	Wide, flat extension bar. It is used to remove large dents without damaging the paint coating. It can be trimmed to the desired Length. Extraction with a comb lining or adapters 351730, 351731.	
	351722	APP LWK 3 Pulling skirt - green multipad for glue 6 x 22 x 156 mm (1 pcs.)	Medium flat pull-out bar. They are used to remove large dents without damaging the paint coating. It can be trimmed to the desired Length. Extracting using a comb lining or adapters 351730, 351731.	
	351723	APP LWK 4 Pulling skirt - blue multipad for glue 6 x 36 x 156 mm (1 pcs.)	Medium flat pull-out bar. They are used to remove large dents without damaging the paint coating. It can be trimmed to the desired Length. Extracting using a comb lining or adapters 351730, 351731.	
	351724	APP LWK 5 Pulling skirt - yellow, triangle shaped for glue 6 x 22 x 156 mm (1 pcs.)	Triangular extension strip. It is used to pull out the edges and embossing without damaging the paint coating. It can be trimmed to the desired Length. Pulling out a using a comb lining or adapters 351730, 351731	
	351730	APP LWK 2 Adapter for removing the battens, single M10 x 1,5	Adapted to work with beams pulling out. It allows simultaneous pulling out two slats.	to order

ACCESSORIES FOR SPOT REPAIRS - PULLER

Photo	APP NO.	Description	Product information	QR CODE
	351731	Adapter for removing the battens, single M14 x 1,5	Adapted to work with counterweight (punchers). It allows simultaneous pulling out two slats.	to order
	351680	NTools V125 Dent Suction cup, big	The suction cup features a 125 mm rubber mount which enables repair of large dents. NTools V125 is a tool dedicated for work with non-rigid bodywork elements, such as doors, roof, engine cover, the side panels of delivery vehicles, etc.	
	351681	NTools V75 Dent Suction cup, small	The suction cup features a 75 mm rubber mount which enables repair of smaller dents. The suction cup is made out of a high quality plastic material and rubber. The flexible mount makes it possible to adapt the tool to nearly any surface being repaired. The upper section of the handle features valve which releases the suction cup from the bodywork. NTools V75 is a tool dedicated for work with non-rigid bodywork elements, such as doors, roof, engine cover, the side panels of delivery vehicles, etc.	
	351686	Adapter for mushroom punch for hot glue	To be attached to the striker (counterweight) with M14 x 1.5 thread. It is used to repair dents without varnishing with plastic mushrooms and hot glue. The set includes an absorbing ring kinetic energy.	to order
	351645	Hammer aluminum small 90g	Aluminum hammers are perfect to relax the repaired element because they are made of more softer material than the part being repaired.	to order
	360753	NTS MDW Hammer circular duplex (Teflon-rubber)	Precise small hammer with the round beaters for auto body repairs, with Teflon and rubber beater. Peen diameter around 12mm. Purposed mostly for finishing works or non-noninvasive repairs made on the top coat.	

BODYWORK REPAIR



Welding: OHS

305-351 BODYWORK REPAIR

- 305 - 306 Panel repair sets
- 307 - 312 Spotters and accessories
- 313 - 318 Consumables for spotters: electrodes, rivets, triangles
- 319 - 320 Welding: wires, nozzles, grips
- 321 - 324 Panel repair tongs
- 325 - 328 Spreaders, pullers and clamps
- 329 - 342 Specialized body repair tools
- 343 - 348 Car body repair - non-invasive methods
- 349 - 351 • Welding: OHS**

• NTools GSS TRUE COLOR

Auto-darkening welding goggles with face shield

The NTools GSS PRO are auto-dimming welding goggles designed to protect the eyes and face against sparks, chipping and harmful radiation in normal welding conditions. The auto-dimming filters automatically transition from dark to bright when the welding arc is extinguished. The goggles are compliant with the EN175 and EN379 European standard.

Welding methods: SMAW - shielded metal arc welding, TIG GTAW - gas tungsten arc welding, MIG(Heavy) - MIG for heavy metals, SAM - semi-automatic shielded electrode arc welding, MIG(Light) - MIG for light alloys, PAC - plasma cutting, PAW - plasma welding

➤ FEATURES

- Ability to adjust the dark to bright transitioning delay
- Adjustable sensitivity improving the operators comfort
- Option selection: welding / plasma cutting / grinding
- Power supply: photovoltaic cell + CR2450 battery (battery life ? 5000 hours)
- Auto-dimming UV/IR filters provide protection up to DIN 16.

➤ TECHNICAL DATA

Model	NTools GSS TRUE COLOR
Index	091318
Filter Size	190.5 × 77.5 × 76.25 mm
Active Viewing Area	122.5 × 35 mm
Light Shade	DIN4
Dark Shade	DIN5 ~ DIN9 / DIN9 ~ DIN13
Way to shift Dark State	Outer , stepless shift
Switching Time	3503 / 10000 S
Sensitivity Adjustment	Stepless Control
Delay Time	0.1S ~ 1.0S
Power supply	Lithium Battery CR2450
Rated Capacity of Lithium Battery	600 mAh
Replaceable Lithium Battery	YES
Operating Temperature	-5°C ~ +55°C
Sensors to Weld Arc	2 sensors
Protect Grade against UVB	DIN16
Grind	YES
Cut	YES
Low battery	YES
Test	NO
Welder filter	TRUE COLOR



• NTools MASTER II

Self-darkening welding visor TRUE COLOR

NTools Master II - a self-darkening welding visor designed to protect the eyes and face from sparks, spatter, and harmful radiation under normal welding conditions. The self-darkening filters automatically switch from dark to light when the welding arc goes out. The use of TRUE COLOR filter enables fuller color reproduction and much clearer image of the welding pool with its surroundings. NTools MASTER II visor meets the requirements of European standards EN175, EN166, and EN379.

Welding methods: MMA, MIG, MAG/CO2, TIG and Plasma, gouging, and plasma cutting

➤ FEATURES

- ADF TRUE COLOR welding filter
- low weight - 550 g
- large field of view - 92 x 42 mm
- large range of header adjustment
- material - nylon

APP NO.	Description	Field of view
091317	Filtr TRUE COLOR	92 x 42 mm



• NTools PSS STN

Self-darkening welding visor

NTools PSS STN - self-darkening welding visor designed to protect the eyes and face from sparks, spatter, and harmful radiation under normal welding conditions. The self-darkening filters automatically switch from dark to bright state when the welding arc goes out.

NTools PSS STN visor meets the requirements of European standards EN175.

Welding methods: MMA, MIG, MAG/CO2, Plasma, gouging, and plasma cutting

➤ FEATURES

- clear glass with green glow.
- low weight - 460 g.
- large field of view - 92 x 42 mm
- detection sensitivity - gradual adjustment by 2
- material - polypropylene

APP NO.	Description	Field of view
091316	DIN 4 / 9-13 / filtr standard	92 x 42 mm



- **NTools MASTER II FILTER**
Self-darkening filter for MASTER II welding visor

APP NO.	Product name
091317F	NTools MASTER II FILTER



- **NTools PSS STN FILTER**
Self-shielding filter for PSS STN welding visors

APP NO.	Product name
091316F	NTools PSS STN FILTER



- **NTools MASTER II PSW**
Protective inner pane for MASTER II welding visor

APP NO.	Product name	Size
091317W	NTools MASTER II PSW	53 x 101 mm



- **NTools MASTER II PSO**
Front protective glass for MASTER II welding visor

APP NO.	Product name	Size
091317P	NTools MASTER PSO PSW	103x118 mm



- **NTools PSS STN ZSO**
Set of visors (external/internal) for PSS STN welding visor

APP NO.	Product name	Size
091316S	NTools PSS STN ZSO	internal 47 x 100 mm, external 91 x 118 mm



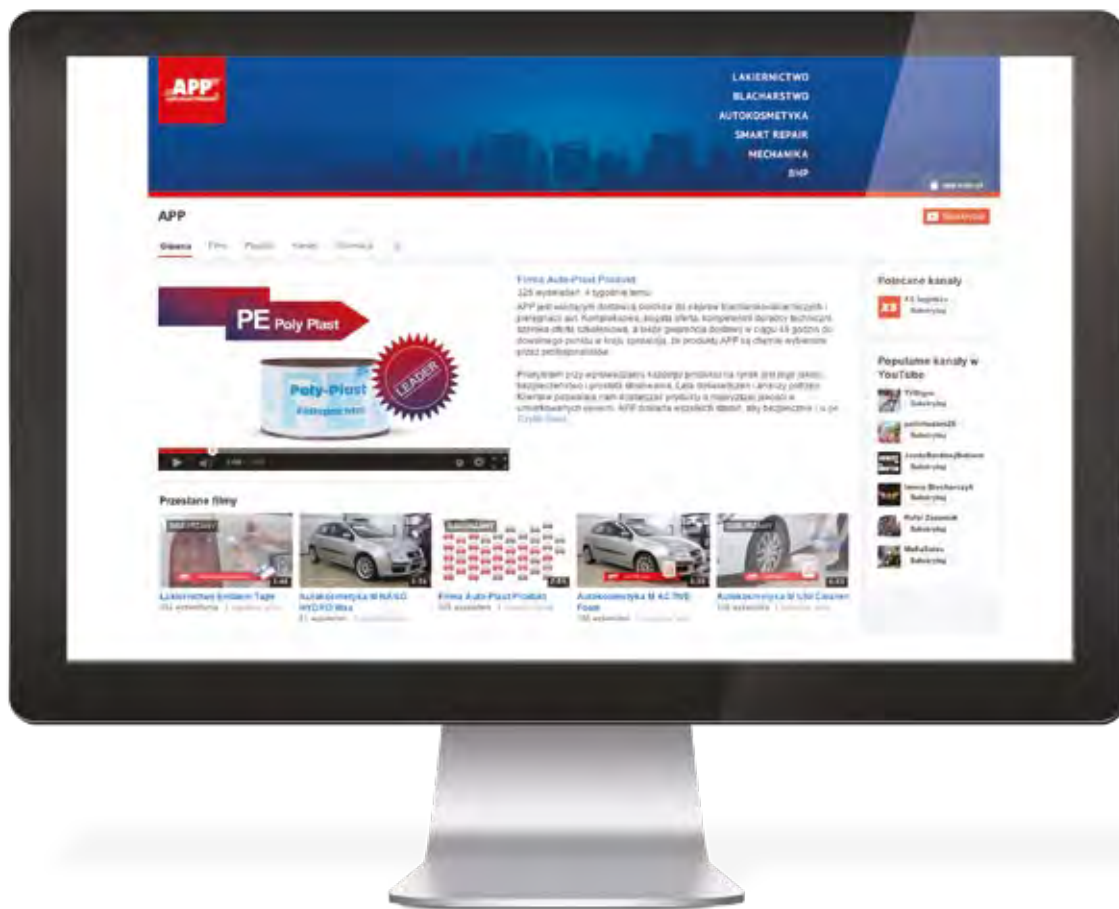

NEW PRODUCTS
PROFESSIONAL REPAIR PROCESSES
NEW TECHNOLOGIES



APP videos on the channel **You**Tube
www.youtube.com/user/autoplastprodukt

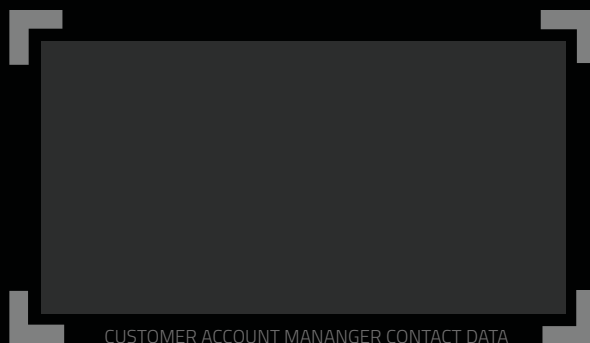

CUSTOMER ACCOUNT MANAGER CONTACT DATA

**CUSTOMER
SERVICE DEPARTMENT**

 **+48 61 437 00 20**

 **bok@app.com.pl**

www.APP.com.pl

APP Sp. z o.o.

ul. Przemysłowa 10, 62-300 Września
+48 61 437 00 00, app@app.com.pl

 **www.facebook.com/APPautoplastprodukt**

 **www.youtube.com/autoplastprodukt**

Indeks no. 890302



5 907782 005580